

Distribution Apparatus

YCQ9 Automatic transfer switch

General



YCQ9 series automatic transfer switch is suitable for AC 50Hz, rated working voltage AC400V, rated operating current up to 630A three-phase four-wire dual-circuit power supply grid, automatically connect one or several load circuits from one power supply to another to ensure load normal power supply of the circuit. This product is suitable for industrial, commercial, high-rise and residential buildings, etc.more important places.

Standard: IEC 60947-6

Features

1. Full range of dual-input single-output(up in and down out),convenient wiring and cost-saving.
2. Handle front operation for convenience and labor-saving
3. Compact size for space saving
4. Two controllers to meet different user needs
5. Low main circuit impedance and energy consumption
6. Reliable double interlock protection function
7. Instantaneous structural design, cleverly driven by dual springs, with a simple and stable structure
8. Rotary contact structure, circular arc extinguishing device design, good arc extinguishing performance, and long contact working life

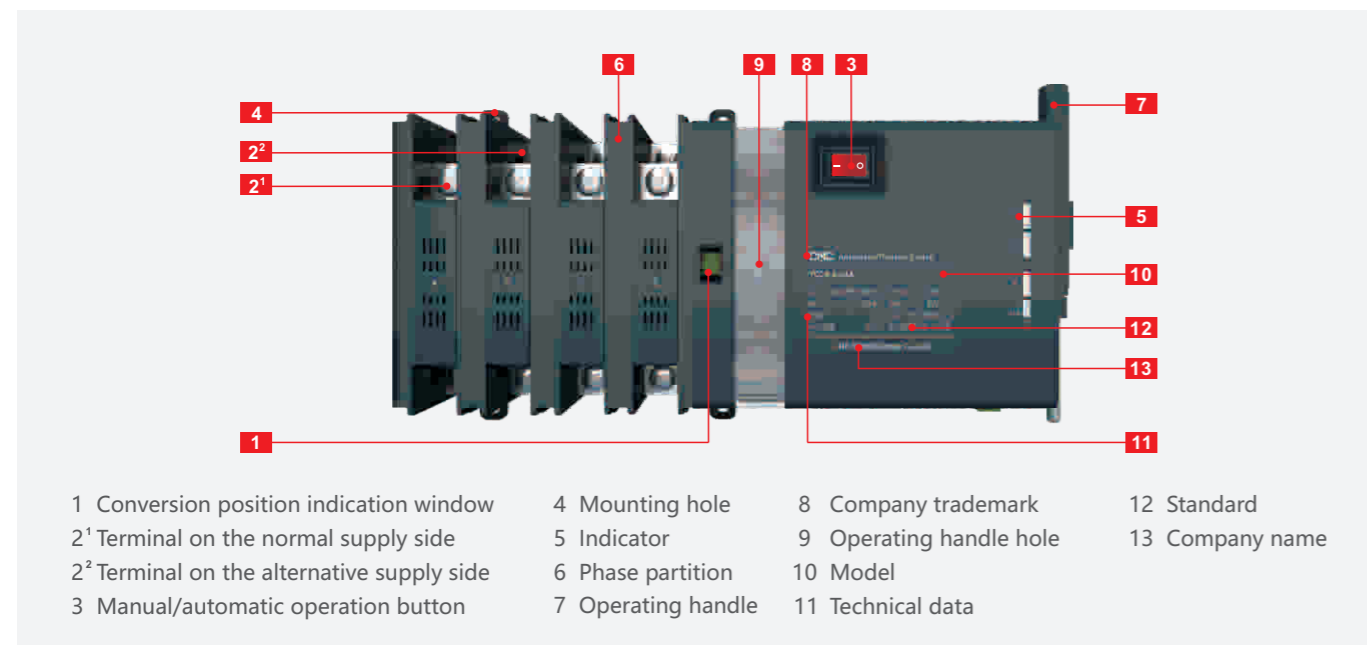

- Control voltage: switch control voltage level is 230V
- Position indication: Indicates the position of the switch working state (I, O, II)
- Main body of the switch: the front part is the I road, which is connected to the "normal power supply"; the rear part is the II road, which is connected to the "standby power supply"

Distribution Apparatus

YCQ9 Automatic transfer switch

Selection

YCQ9 Model	63 Shell frame	3 Number of poles	A Controller type	16A Rated current	FFD Function
Automatic transfer switch(PC class)	63(16~63A) 125(50~125A) 250(125~250A) 630(250~630A)	2: 2P 3:3P 4:4P	A: Economy	16A 20A 25A 32A 40A 50A 63A 80A 100A 125A 160A 200A 225A 250A 315A 350A 400A 450A 500A 630A	/
			B: Standard		/:Fire control linkage FF:Fire feedback D:Generator FFD:Fire feedback, Generator

Distribution Apparatus

YCQ9 Automatic transfer switch

Technical data

Model	YCQ9-63	YCQ9-125	YCQ9-250	YCQ9-630
Function	Isolation, switch			
Structure	Integrated			
Electric equipment level	PC class			
Utilization category	AC-33B			
Number of poles	2P、3P、4P			
Electrical performance				
Rated insulation voltage U_i (V)	AC800			AC1000
Rated operating voltage U_e (V)	AC400 (2P product AC230)			AC415
Rated current I_e (A)	16,20,25,32,40,50,63	50,63,80,100,125	125,160,200,225,250	250,315,350,400,450,000,000
Rated operating frequency (Hz)	50			
Rated impulse withstand voltage U_{imp} (kV)	8		12	
Rated impulse withstand current I_{cw} (kA)	5/30ms	10/30ms	25/1ms	
Rated short-circuit making capacity I_{cm} (kA)	8	17	52.5	
Contact transfer time (s)	0.6±20%			
Operating transfer time (s)	1.3±10%			
Return time (s)	1.3±10%			
Power outage time (s)	0.6±20%			
Operation method	Auto/Manual			
Switch position	Normal (I) 、 Power outage (O) 、 Standby (II)			
Mechanical endurance (times)	8000 (*)		4000 (*)	
Electrical endurance (times)	2000 (*)		1000 (*)	
Applicable environmental conditions and installation				
Working temperature (°C)	-5~+40			
Altitude (m)	≤2000			
Atmospheric conditions	The relative humidity of the atmosphere shall not exceed 50% at the highest ambient temperature of +40 °C. At lower temperatures, there can be higher relative humidity, such as reaching 90% at +20 °C. Special measures should be taken for occasional condensation caused by temperature changes;			
Pollution degree	3			
Installation environment	Places without obvious vibration and impact			
EMC environment	Environment B			
Protection degree	IP20			
Power supply voltage deviation range (V)	160±10%			
Normal working voltage range	85% U_e ~110% U_e			
Installation	Vertical fixed installation			
Wiring method	Screw wiring			
Connection	Front connection			
Maximum number of conductors allowed to be clamped in	1			2
Maximum screw torque	2.5	6	10	22

Note:(*) Maintainable

Distribution Apparatus

YCQ9 Automatic transfer switch

Parameters of controller

Type	Type A	Type B
Power supply and opening/closing indication	■	■
Automatically transfer and restore operation	■	■
Grid-grid	■	■
Grid-generator(start/stop)	-	□
Three-phase monitoring commonly used to detect phase loss in power supply	■	■
Three-phase monitoring commonly used to detect power loss in power supply	■	■
Single-phase monitoring commonly used to detect phase loss in power supply	■	■
Single-phase monitoring commonly used to detect power loss in power supply	■	■
Handle manual operation	■	■
External wiring terminal of indicator light	■	■
Fire control linkage(24VDC)	-	□
Fire feedback	-	□

Note: "■" Standard, "□" Optional, "-" No.

Overall and mounting dimensions

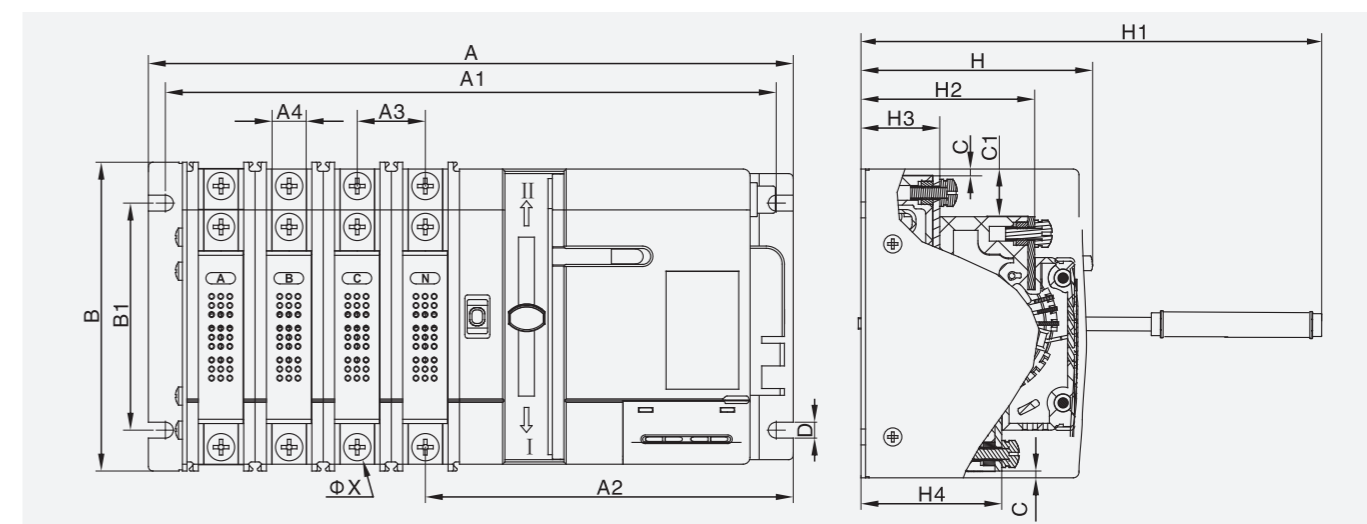

Specifications	A			B	H	A1			B1	A2	A3	A4	H1	H2	H3	H4	C	C1	D	ΦX
	2P	3P	4P			2P	3P	4P												
63	171	193	215	138	68	44	66	88	106	136	22	13	152	52	24	43	2	13	5.2	6
125	229	259	289	136	102	214	244	274	100	162	30	15	240	77	35	62	4	21	7	6
250	302	347	393	170	128	283	328	374	125	207	45.5	25	257	96	44	79	4	22	9	8
630	460	528	596	255	192	433	501	569	188	325	68	49	367	144	65	118	6	40	13	120

Note:The operating handle is usually removed and used for emergency or manual operation.

YCQ9 Automatic transfer switch

Controller

Interface of the display module of controller

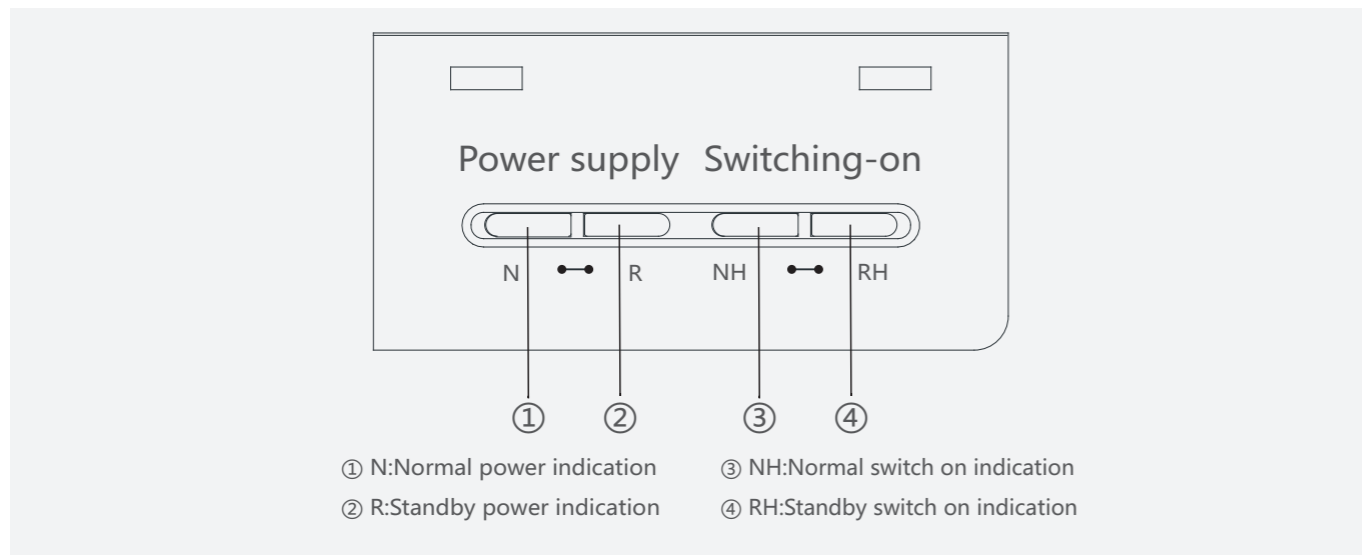

Controller action flow

Secondary wiring diagram of economy and basic controllers

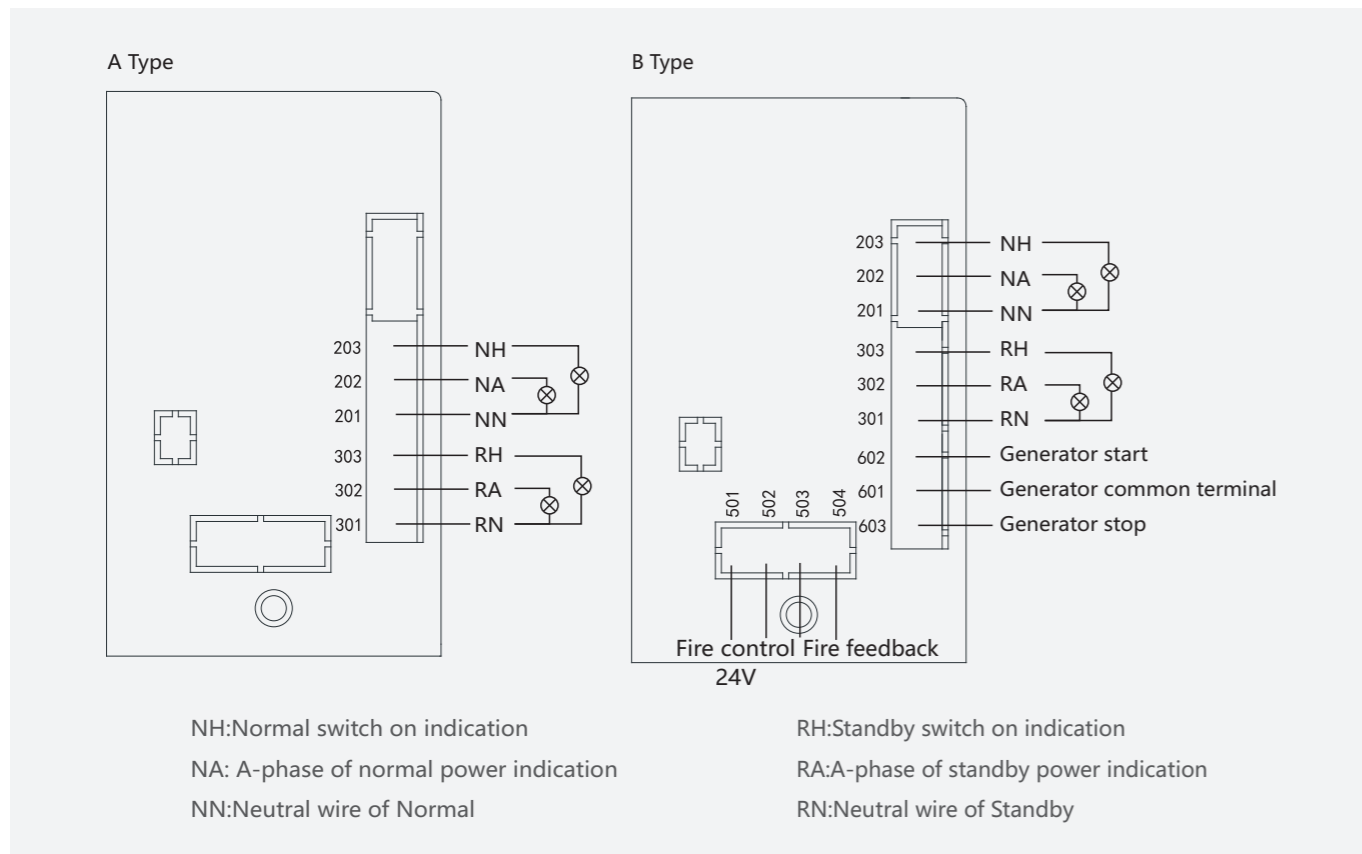

YCQ9 Automatic transfer switch

Wiring diagram

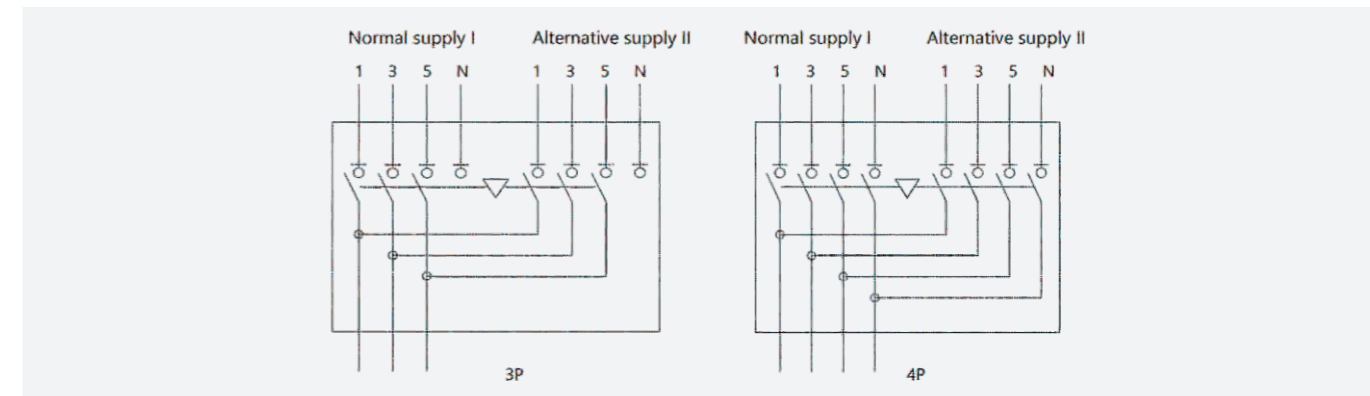

Note: Three-pole products must have the neutral wire connected to the controller(Normal neutral wire access 101)(Standby neutral wire access 201)

Controller action flow

Automatically transfer and restore operation (power grid-power grid) work flow diagram of controller

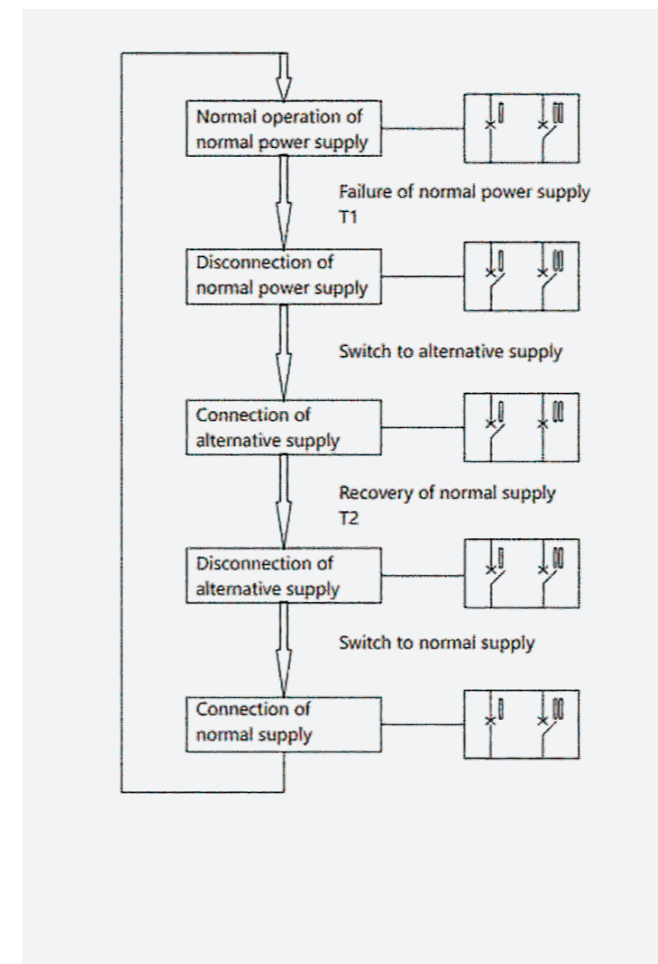

Automatically transfer and restore operation (power grid-generator) work flow diagram of controller

