

# XMT -9000

## Intelligent Thermoregulatory Operating Handbook

### Warning

- 1.Connecting warning  
Installed the outside protection circuit can prevent system malfunction caused by the invalidation and fault of the instrument.
- 2.Power supply  
To avoid the invalidation and fault of the instrument, choose the power source with rated voltage.  
To avoid the electronic shock and instrument invalidation, just supply the power after all the connections are finished.
- 3.Forbid to use the instrument close to explosive gas  
To avoid the fire, explosion and instrument damage, forbid to use the instruments in the location with explosive, inflammable and steamy gas.
- 4.Forbid to touch the inside of instruments.  
To avoid the electronic shock or combustion, forbid to touch the inside of the instrument. Only the service engineer of our company can check the inside lines or change exchange the components.  
There is high voltage inside, so touch the inside is very dangerous.
- 5.Forbid to change the instruments' structure.  
To avoid the accident and invalidation of instruments, it's forbidding to change the instruments' structure. Only the service engineer of our company can change the components.  
To ensure the durative and safe using of the instruments, please maintain the instruments termly. Some parts or components may be damaged with the time flying.

## Brief introduction

XMT -9000 intelligent temperature controllers are the multi-functional regulators adopting the micro processing units. As also adopting the switch power source and Surface Mount Technology(SMT), it is small and has great performance. The special self-diagnosis, self-conditioning and intelligent functions bring good efforts through simple operating.

## Main technologies indicates

### 1. Input

Any kind of TC, RTD's standard signal of current and voltage (see the kinds sheet of input)

### 2. Accuracy

Measure accuracy:  $\pm 0.5\%FS$

Cold-end Compensation deviation: in the range of  $\pm 2^{\circ}C(0\sim 502^{\circ}C$  can be amended by the software)

Resolving power: 14bit

Sampling cycle: 0.5 Sec

### 3. Display

PV、SV: -1999 ~ +1999

Indicates of output、alarm、self-conditioning: LED

### 4. Controlling output

1.Current output: DC 0 ~ 10 mA, 4 ~ 20 mA (RL < 500 $\Omega$ )

2.Voltage output: DC 0 ~ 5 V, 1 ~ 5 V (RL > 10K)

3.Relay output: contact capacity 250VA (resistance load)

4.Voltage pulse output: 0 ~ 12V, (suitable for the solid relay SSR)

5.Controlled Silicone SCR output: over zero trigger or phase trigger (resistant load)

6.Alarm function output: 2 groups output at most, 12 modes.

Capacity of the output contact: 250V AC 3A (resistant load)

### 5. Setting range

Setting value (SV): Measured Present Value (PV)

Proportional band (P): 0 ~ whole measured range (when set 0, it's ON/OFF control)

Integral time: 0~3600 Sec (when the time is 0, the function of integral time closed)

Derivative time: 0~3600 Sec (when the time is 0, the function of differential time closed)

Proportional term: 1~100 Sec

Hysteresis loop Width of the phase controlling output: 1~100 $^{\circ}C$  (or other pv units)

### 6. Others:

Insulation resistance: >500 M (500DC)

Insulation strength: 1500VAC/1min

Power consumption: <10VA

Using environment: 0~50 $^{\circ}C$ , 30~85% RH no corrosive atmospheres environment

Weight: about 0.5kg

# Connection

## 1. Size

Model	Size (mm)			Hole Size (mm)	
	height	width	length	height	width
XMTG-9000	48	48	110	45	45
XMTF-9000	48	96	110	45	92
XMTE-9000	96	48	110	92	45
XMTD-9000	72	72	110	68	68
XMTA-9000	96	96	110	92	92
XMT-9000	80	160	90	76	156
XMTS-9000	160	80	90	156	76

## 2. The diagram of lines connection (subject to the diagram of the instruments itself)

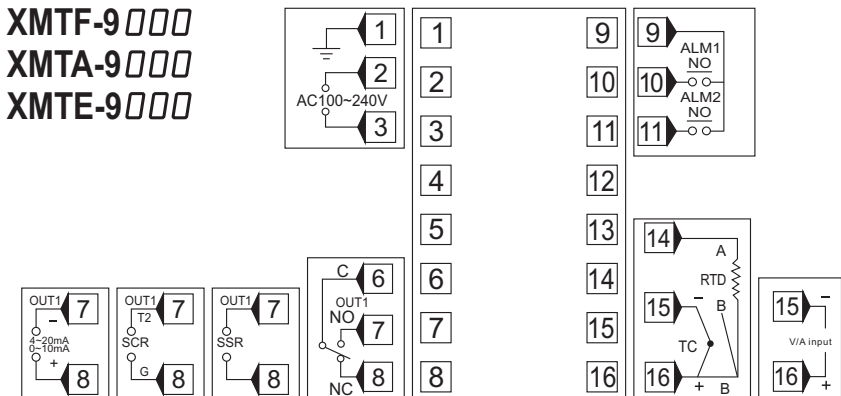
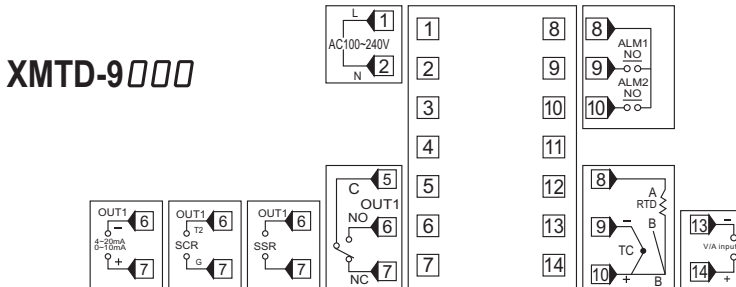
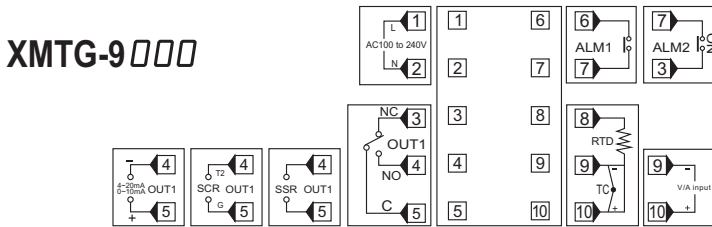

# XMT-9000 XMTS-9000

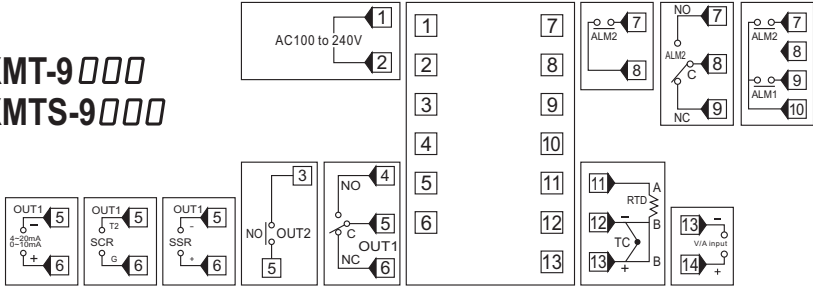

**TC input: Thermocouple input      RTD input: Thermo resistance input**  
**V/A input: voltage and current input**

Type named

**XMT0-9000**

- ① Size (Height x Width) :
  - A. 96 x 96 ( 92 x 92 )
  - D. 72 x 72 ( 68 x 68 )
  - E. 48 x 96 ( 45 x 92 )
  - F. 96 x 48 ( 92 x 45 )
  - G. 48 x 48 ( 45 x 45 )
  - T. 160 x 80 ( 152 x 76 )
  - S. 80 x 160 ( 76 x 152 )
- ② adjustment method
  - 0-No. PID function
  - 2-upper and lower limit control function
  - 4-PID adjustment with contact output break-make
  - 5-PID adjustment with drive solid relay
  - 6-PID adjustment of output single phase trigger signal
  - 7-PID adjustment of output single phase over-zero signal
  - 8-PID adjustment of output three phase over-zero signal
  - 9-PID adjustment of output 0-10mA or 4-20mA,etc such current
- ③ Alarm function
  - 0-no alarm function
  - 1-upper limit contact ouput alarm function
  - 2-lower limit contact ouput alarm function
  - 3-upper lower limit contact ouput alarm function
- ④ Input signal:
  - 1-TC (mv):K,E,J,S,B,R,N,T,etc.
  - 2-RTD ( ) : Pt100,JPt100,etc.
  - 3-0~5V,1~5V, voltage signal
  - 5-Stand current:0~10mA,4~20mA

Note: tell (fill the sheet) detail according to the above when ordering.

Face board name and the functions

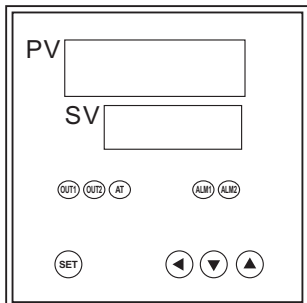

NO	Face board description	Content description
1.	PV	Measured present value/mode displayed value
2.	SV	Setting value/mode content displayed value
3.	OUT1	Output 1 indicating light
4.	OUT2	Output 2 indicating light
5.	AT	PID automatic calculating light
6.	ALM1	Alarm 1 indicating light
7.	ALM2	Alarm 2 indicating light
8.	▲	Addend key
9.	▼	Subtrahend key
10.	<	Phase shift key
11.	SET	Set/mode key

## Operating flow

Start flow:

Sheet A

Display	h	J	r	S	b	E	n	r	Pt	JP	h	
Input type	TC								RTD		Voltage/current	
	K	J	R	S	B	E	N	T	Pt100	JPt100	mV	mA

### SV setting mode

Under the normal SV/PV display mode, press the “SET” key, makes the SV display under the glistening state, through pressing “<” to find the needed fingers, then press “^” or “v” to set the needed temperature value, then press the “SET” key again to return the instrument to the SV/PV normal display state.

### Parameter setting mode

It is used for the alarm setting, PID constant and such parameters. In the normal display state, press the 【SET】 key for three seconds, the parameter setting mode is displayed in the PV screen, and the corresponding value is showed in the SV screen., press the "SET" key in order will show follow parameter signals:

**Note:** the instrument has the automatic reply function,. When the operators do the parameters and such setting activities but forget to return to the “SV/PV” display mode, the instrument will return to the “SV/PV” automatically 30 seconds later.

Please reader follow contents detail before you change the parameters.

If the instrument doesn't have some functions, then the follow flow sheet will not show such functions.

Signal	Name	Description	Setting range	Value leaving factory
AL1	Alarm 1 setting	Set the value of alarm 1 and alarm 2	Whole measured range	50.0 or 50
AL2	Alarm 2 Setting		Whole measured range	50.0 or 50
ATU	Adjustment automatic	Make sure ATU open/closed	0: closed ATU 1: open ATU	0
STU	Correction automatic	Make sure STU open/closed	0: STU finished or stopped 1: STU starts	0
P	Proportional band (heat)	Set the value of proportion	0-Wholemeasured range: when 0, means ON/OFF control	30 or 3.0 (see*1)
I	Integral time (Sec)	Set integral time to eliminate the error of proportional band	0~3600 (Sec) : When 0, no integral time effect	240
D	Derivative time (Sec)	Set derivative time to avoid the fluctuation of output	0~3600 (Sec) When 0, no derivative time effect	60
Ar	Limit the effective range of integral activity	Prevent integral activities exceed the limit or be deficient	Proportional band 1-100% (heating)	100
T	Proportional term (refrigerating)	Setting t refrigerating's proportional term	1~100 sec (can't be 0) no display when current output	see*3
Pb	Procedure deviation value	Sensor's measured value add this value is to be the PV	Temperature input -1999~9999或199.9~999.9 Voltage/current $\pm$ measured range, unit is as same as PV	0 or 0.0
LCK	Setting the function of data's lock	Make the data change validity or invalidity	see*4	0000

\*1. When  $P \neq 0$ , the instrument is under PID control, this time should set I, D value reasonably. At the first time using, you can open the 'AT' automatic adjustment function to make the control under the best state; when  $P=0$ , it is under ON/OFF control, you should set the value of return difference--OH.

\*2. Relay contact output: 20 seconds, voltage pulse output/flow control pipe drive uses the trigger output/ flow control pipe output 2 seconds.

\*3. Options of data lock levels.

Setting data lock function is using to prevent the mistaken operations of the not often used parameters. When the parameters are locked, they can't be set or changed but only be monitored.

.5.

Setting	Protect range of different lock levels
0000	SV and the whole parameters can be set
0001	Just SV, AL1, AL2 can be set
0011	Just SV can be set
0111	SV and all the parameters can't be set

## Breakdown signal indication

When the instrument doesn't work normally, it will diagnosis itself and shows the promotion.

Signal	Description	Solution methods
Err	Instrument breakdown	Please send it to check and mend
oooo	Input fault` positive electrode and negative electrode are connected opposed or the input exceeds the range	Please check the input signal to see whether there are mistakes.
uuuu	Input fault` positive electrode and negative electrode are connected opposed or the input lower than range	Please check the input signal to see whether there are mistakes.

## The set of instrument engineer's parameter mode

After the instrument be electrified, press parameter mode to enter and find the data lock parameter "LCK", and set its code to be "1000", press "SET" again to make the instrument confirm., press "SET" key and "<" key simultaneously, about 3 seconds later, when the PV screen shows "Cod" =1000, press "SET" key can get follow parameters display in order:

Signal	Setting value				Description	Measure range
SL1	0	0	0	0	K	0~1372°C
	0	0	0	1	J	0~1200°C
	0	1	0	1	T	-200~400°C/-199.9~400.0°C
	0	0	1	1	E	0~800°C
	0	1	0	0	N	0~1300°C
	0	1	1	1	R	0~1769°C
	1	0	0	0	S	0~1769°C
	1	0	0	1	B	0~1820°C
	1	1	0	0	Pt100	-200~650°C/-199.9~650.0°C
	1	1	0	1	Cu50	-50~150°C/-50.0~150.0°C
	1	1	1	0	0~5V	-1999~9999
	1	1	1	1	1~5V	-1999~9999
	1	1	1	0	0~20mA	-1999~9999
	1	1	1	1	4~20mA	-1999~9999

SL2	0	0	0	0	leave out	
SL3	0	0	0	0	leave out	
SL4		0	0	0	Not set Alarm 1 yet	Alarm 1 (ALM1) types selection
		0	0	1	Upper limit deviation alarm	
		0	1	0	Upper/lower limit deviation alarm	
		0	1	1	Procedure value upper limit deviation alarm	
		1	0	1	Lower limit deviation alarm	
		1	1	0	Alarm (Alarm in the range)	
		1	1	1	Procedure value lower limit alarm	
	0				No await alarm function	Alarm 1 await functions selection
	1				Await alarm function	
SL5	0	0	0	0	Alarm 2 function setting	As the same as alarm 1
SL6				0	Right activity control(refrigerating)	Main control right/contrary activities selection
				1	Contrary activities control(heating)	
		0			Main controlling time proportional output	Main control output types selection
		1			Main control continuous output(4~20mA)	
SL7				0	Incentive alarm	Incentive alarm/ Non-incentive alarm (Alarm 1)
				1	Non-incentive alarm	
			0		Incentive alarm	Incentive alarm/ Non -incentive alarm (Alarm 2)
			1		Non-incentive alarm	
SL8	0	0	0	0	leave out	
SL9	0	0	0	0	leave out	
SL10	0	0	0	0	leave out	
SL11	0	0	0	0	leave out	

When “Cod”=0001, press “SET” different times can get the follow parameters display in order:

Signal	Value leaving factory	Description	Setting range
SLH	According to the order	Set value measures the upper limit of the range	See above sheet
SLL	According to the order	Set value measures the lower limit of the range	See above sheet
PGdP	0	The number of digits after dot	0-3
OH	2 or 2.0	AT automatic adjustment	0-100 or 0.0-100.0
AH1	2 or 2.0	Alarm 1 no activity band width	0-100 or 0.0-100.0
AH2	2 or 2.0	Alarm 2 no activity band width	0-100 or 0.0-100.0



CTr	800	Rate of current transformer	0~9999
dF	1	Digit filter constant	0-100
STTM	100	The time factor that makes the measured value steady	0~200
STPK	67	The factor of proportional band calculation	0~200
STIK	16	The factor of integral calculation	0~200

1. Instrument maintains and keeps
2. Since giving invoice for 18 months, our company will mend the instrument if the instrument broke down because of the problem of quality, but if it broke down because of unsuitable using, the company will collect reasonably fee for mending. However, our company's instruments we in charge of their over their lives.
3. The instruments should be stocked in the dried, ventilated, and non-corrosive gas environment with complete package.