

YCB3000
Inverter Series
Product specification

CNC



PREFACE

First of all, thank you for purchasing the YCB3000 series frequency inverter developed and produced by our company!

The YCB3000 series frequency inverter is a general-purpose high-performance current vector inverter, which is mainly used to control and adjust the speed and torque of three-phase AC asynchronous motors. YCB3000 uses high-performance vector control technology, low-speed and high-torque output, with good dynamic characteristics, super overload capacity, stable performance, powerful protection function, simple man-machine interface, simple operation. Can be used for weaving, paper, wire drawing, machine tool, packaging, food, fan, water pump and a variety of automatic production equipment drive.

This manual will provide you with relevant details, and notes for the installation, wiring, functional parameters, routine maintenance, troubleshooting of YCB3000 series inverter. To properly use the YCB3000 series of frequency inverters, maximize the excellent performance of the product, and ensure the safety of users and equipment, be sure to read this manual in detail before using this series of frequency inverters.

Due to the continuous improvement of the product, the information provided by the company will not change without further notice. If you have difficulties in the use of this series of inverter or have special requirements, please contact our company after-sales service center, we will serve you wholeheartedly!

Contents

Chapter 2. product information

2.1 Nameplate and model	02
2.2 Model and technical data of frequency inverter	03
2.3 Appearance and installation dimensions	07
2.4 Wiring of the main circuit and the control circuit	09

Chapter 3 Panel operation

3.1 Panel operation instructions	15
3.2 Introduction of the LED operation panel	15
3.3 Opening size of the panel tray	18

Chapter 4 Functional parameters table

4.1 Table of basic function parameters	19
4.2 Monitor parameter brief	51

Chapter 5 Fault diagnosis and countermeasures

5.1 Safety precautions	53
5.2 Adjustment guide before the frequency inverter for trial operation	54
5.3 Fault alarm and countermeasures	56
5.4 Common faults and handling methods	61

V/F curve running mode according	63
Set the main frequency by "analog"	63

Chapter 2: Product Information



Safety precautions

- Do not grab the front cover or terminal cover to handle the inverter. If only grasp the front cover plate, it will make the main body fall, there is a danger of injury;
- Operates the inverter, follow the steps specified in the static precautions (ESD). Otherwise, the internal circuit of the inverter will be damaged due to static electricity.

2.1 The nameplate and model shall refer to page 8 of the old manual

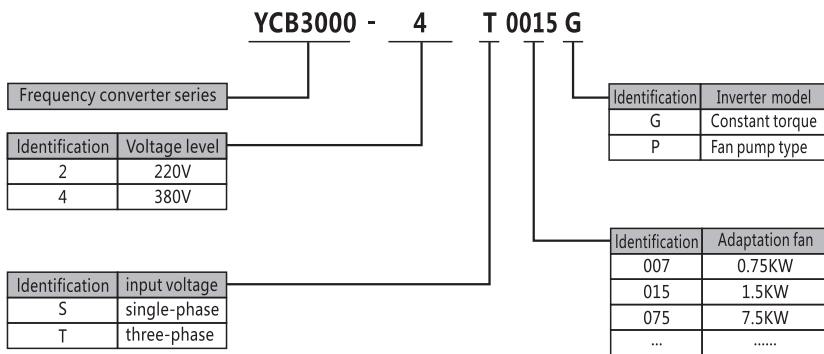
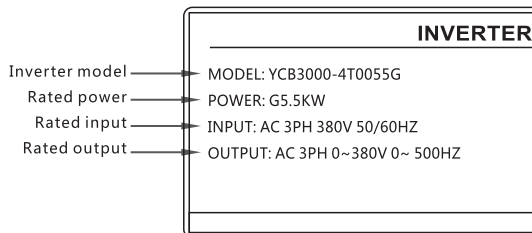

Figure 2-1 Product naming and nameplate identification



2-2 Definition of frequency converter nameplate



- 3-phase 380V~480V, 37G and below has internal brake units.

2.2 Technical specifications of frequency converter

Table 2-2 Technical specifications of YCB3000 series inverter

	project	technical specifications	
Basic function	Input the frequency resolution	Number setting: 0.01Hz, simulation setting: maximum frequency 0.025%	
	control method	Open-loop vector control (SVC), closed-loop vector control (FVC) (0.75kW-5.5kW No Such Function) V / F control.	
	pull-in torque	0.25Hz/150%(SVC);0Hz/180% (FVC)	
	Speed range	1: 200 (SVC)	1: 1000 (FVC)
	Steady speed accuracy	+0.5% (SVC)	+0.02% (FVC)
	Torque control accuracy	FVC: + 3%,SVC: 5Hz above + 5%.	
	Recurrent ascension	Automatic torque increase, manual torque increase of 0.1%-30.0%.	
	V/F curve	Four ways: straight line, multi-point type; complete V/ F separation; incomplete V/F separation.	
	Add deceleration curve	Straight-line or S-curve acceleration and deceleration mode; Four acceleration and deceleration times, acceleration and deceleration time range 0.0.6500.0s.	
	DC injection braking	DC brake starting frequency: 0.00Hz~ maximum frequency; Brake time: 0.0s~36.0s; Brake action current value: 0.0%-100.0%.	
	electronic contro	Tap movement frequency range: 0.00Hz-50.00Hz; Tap action, acceleration and deceleration time is 0.0s-6500.0s.	
	ISimple PLC, multi-segment speed operation	Up to 16 segments can be run with a built-in PLC or control terminal.	
	built-in PID	It can easily realize the process control closed-loop control system.	
	Automatic Voltage Adjustment (AVR)	When the grid voltage changes, the output voltage constant.	
	Over pressure over loss speed control	Automatic limit of current and voltage during operation to prevent frequent excessive flow pressure trip.	
Quick flow	Minimize the over current fault, and protect the normal		
	restriction function	operation of the frequency converter.	
	Torque limit and control	The characteristic of "excavator" automatically limits the torque during operation to prevent frequent current trip; the vector control mode can realize torque control.	
Personalized function	Instantly stop	In case of instantaneous power outage, the frequency converter is maintained to reduce the load feedback energy compensation voltage in a short time.	
	Fast flow limit	Avoid the frequent over current fault of the frequency converter.	
	invented IO	Five sets of virtual DIDO, which can achieve simple logic control.	
	timing control	Timing control function: set the time range of 0.0Min ~ 6500.0Min	
	Multi-motor switching	Two sets of motor parameters, can realize two motor switch control.	
	Multithreaded bus support	Support for six fieldbuses: Modbus, Profibus-DP, CANlink, CANopen, PROFINET, and EtherCAT.	
	Motor overheating protection	With the I/O extension card 1 option, the analog input AI3 accepts the motor temperature sensor input (PT100, Pt1000).	
	Multi-encoder support	Support for differential, open-circuit collector, U/VW, rotary transformer, etc	

project		technical specifications
Run	Run instructions	Operation panel given, control terminal given, serial communication port given. It can be switched in many ways
	Frequency instruction	10 frequency commands: digital given, analog voltage, analog current, pulse, serial port given. You can be switched in many ways
	Auxiliary frequency instruction	10 Auxiliary frequency commands. It can flexibly realize the auxiliary frequency fine-tuning and frequency synthesis
	input terminal	standard: <ul style="list-style-type: none"> ● Five DI terminals, one of which supports a high-speed pulse input of up to 100kHz ● Two AI terminals, 1, one only supports 0-10V voltage input, one supports 0-10V voltage input or 0-20mA current input Extended ability: <ul style="list-style-type: none"> ● The 5 DI terminals of the ● One AI terminal, support-10V-10V, oltage input, and support PT100 / PT1000 support
	leading-out terminal	standard: <ul style="list-style-type: none"> ● One high-speed pulse output terminal (optional as the open-circuit collector type), ● Support the square-wave signal output of 0~100kHz ● 1 DO terminal ● One relay output terminal ● One AO terminal with 0 to 20 mA current output or 0 to 10V voltage output Extended ability: <ul style="list-style-type: none"> ● 1 DO terminal ● One relay output terminal ● One AD terminal with 0 to 20 mA current output or 0 to 10V voltage output
Displays and keyboard operation	LED show	Display parameters
	Parameter copy	Quick replication of the parameters is available through the LCD action panel option
	Key-lock and function selection	Part or all of the keys can be locked to define the scope of some keys to prevent misoperation
protect function	Lack of phase protection	Input phase protection, output phase phase protection
	Instant over current protection	Stop at over 250% of the rated output current
	Over voltage crowbar	Stop when the main circuit DC current is above 820V
	Under voltage protection	Stop when the main circuit DC current is below 350V
	overheat protection	Protection is triggered when the inverter bridge overheated
	overload protection	150% rated current for 60s shutdown (4T4500G: 130% rated current running for 60s shutdown)
	Over current protection	Stop protection exceeding 2.5 times rated current
	Brake protection	Brake unit overload protection, brake resistance short-circuit protection
short-circuit protection	Dutput alternate with short circuit protection, output short circuit to ground protection	

project		technical specifications
Environment	Where to use	Indoor, free from direct sunlight, no dust, corrosive gas, combustible gas, oil mist, water steam, dripping water or salt, etc
	above sea level	Below 1000m, 1% for 100m over 1000m, 1% over 3000m (Note: The highest elevation of 0.4~3kW drive is 2000m, if used above 2000m, please contact the manufacturer)
	ambient temperature	10°C ~ + 40°C, when the temperature exceeds 40°C. The decrease is 1.5% per 1C increase, and the maximum ambient temperature is 50°C
	humidity	Less than 95%RH, no condensation
	vibrate	Less than 5.9m / s ² (0.6g)
	Storage temperature	-20°C~ + 60°C

2.3 frequency converter model and technical data

Frequency converter Model	Power supply capacity is KVA	Input current A	Output current A	Adaptation motor	
				KW	HP
Single-phase power supply: 220V (-10%~+15%) , 50/60Hz					
YCB3000-2S0007G	1.5	8.2	4.0	0.75	1
YCB3000-2S0015G	3.0	14	7.0	1.2	2
YCB3000-2S0022G	4.0	23	9.6	2.2	3
YCB3000-2S0040G	8.9	14.6	13	4.0	5
YCB3000-2S0055G	17	26	25	5.5	7.5
Three-phase power supply: 220V (-10%~+15%) , 50/60Hz					
YCB3000-2T0007G	3	5	3.8	0.75	1
YCB3000-2T0015G	4	5.8	5.1	1.5	2
YCB3000-2T0022G	5.9	10.5	9	2.2	3
YCB3000-2T0040G	8.9	14.6	13	4.0	5
YCB3000-2T0055G	17	26	25	5.5	7.5
YCB3000-2T0075G	21	35	32	7.5	10
YCB3000-2T0110G	30	46.5	45	11	15
YCB3000-2T0150G	40	62	60	15	20
YCB3000-2T0185G	57	76	75	18.5	25
YCB3000-2T0220G	69	92	91	22	30
YCB3000-2T0300G	85	113	112	30	40
YCB3000-2T0370G	114	157	150	37	50
YCB3000-2T0450G	135	180	176	45	60
YCB3000-2T0550G	161	215	210	55	75
YCB3000-2T0750G	236	315	304	75	100

Frequency converter model	Power supply capacity is KVA	input current A	output A	Adaptation motor	
				KW	HP
Three-phase power supply: 380V (-10%~+15%) , 50/60Hz					
YCB3000-4T0015G	3.0	5	3.8	1.5	2
YCB3000-4T0022G	4.0	5.8	5.1	2.2	3
YCB3000-4T0030G	5.0	8.0	7.2	3.0	4
YCB3000-4T0040G	5.9	10.5	9	4.0	5
YCB3000-4T0055G	8.9	14.6	13	5.5	7.5
YCB3000-4T0075G	11	20.5	17	7.5	10
YCB3000-4T0110G	17	26	25	11	15
YCB3000-4T0150G	21	35	32	15	20
YCB3000-4T0185G	24	38.5	37	18.5	25
YCB3000-4T0220G	30	46.5	45	22	30
YCB3000-4T0300G	54	57	60	30	40
YCB3000-4T0370G	63	69	75	37	50
YCB3000-4T0450G	81	89	91	45	60
YCB3000-4T0550G	97	106	112	55	75
YCB3000-4T0750G	127	139	150	75	100
YCB3000-4T0900G	150	164	176	90	120
YCB3000-4T1100G	179	196	210	110	150
YCB3000-4T1320G	220	240	253	132	180
YCB3000-4T1600G	263	287	304	160	210
YCB3000-4T1850G	305	323	340	185	240
YCB3000-4T2000G	334	365	377	200	260
YCB3000-4T2200G	375	410	426	220	285
YCB3000-4T2500G	404	441	465	250	320
YCB3000-4T2800G	453	495	520	280	370
YCB3000-4T3150G	517	565	585	315	420
YCB3000-4T3550G	565	617	650	355	480
YCB3000-4T4000G	629	687	725	400	530
YCB3000-4T4500G	716	782	820	450	600
YCB3000-4T5000G	800	820	900	500	680
YCB3000-4T5600G	930	950	1020	560	750
YCB3000-4T6300G	1050	1050	1120	630	850
YCB3000-4T7200G	1200	1200	1300	720	960
YCB3000-4T8000G	1330	1380	1420	800	1060
YCB3000-4T10000G	1660	1650	1720	1000	1330

2.3 Appearance and installation dimensions

YCB3000--1.5KW-1000KW complete machine size

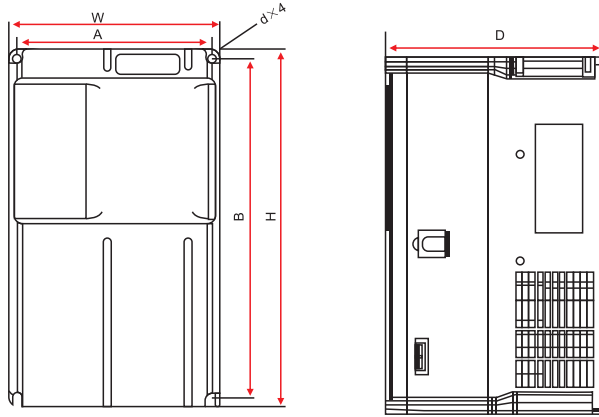

Figure 2-2 Schematic diagram of YCB3000 exterior size and installation size

Table 2-4 YCB3000 external shape and mounting hole dimensions
(3-phase 380V~480V)

Frequency converter model	Install the hole position of mm		External size: mm			Install aperture mm
	A	B	H	W	D	
YCB3000-4T0015G	79	154	165	88	130	Ø4
YCB3000-4T0022G						
YCB3000-4T0030G						
YCB3000-4T0040G	86	173	185	97	145	Ø5
YCB3000-4T0055G						
YCB3000-4T0075G	131	245	258	145	195	Ø6
YCB3000-4T0110G						
YCB3000-4T0150G						

Frequency converter model	Install the hole position of mm		External size: mm			Install aperture mm
	A	B	H	W	D	
YCB3000-4T0185G	151	303	320	170	220	Ø6
YCB3000-4T0220G						
YCB3000-4T0300G	120	385	400	200	235	Ø7
YCB3000-4T0370G						
YCB3000-4T0450G	200	493	510	260	260	Ø7
YCB3000-4T0550G						

Frequency converter model	Install the hole position of mm		External size: mm			Install aperture mm
	A	B	H	W	D	
YCB3000-4T0750G	200	630	660	300	270	Ø9
YCB3000-4T0900G						
YCB3000-4T1100G						
YCB3000-4T1320G	250	755	780	400	345	Ø12
YCB3000-4T1600G						
YCB3000-4T1850G						
YCB3000-4T2000G	300	872	900	460	355	Ø12
YCB3000-4T2200G						
YCB3000-4T2500G	360	922	950	500	355	Ø12
YCB3000-4T2800G						
YCB3000-4T3150G	500	1029	1050	650	365	Ø12
YCB3000-4T3550G						
YCB3000-4T4000G	500	1265	1300	650	385	Ø14
YCB3000-4T4500G						
YCB3000-4T5000G						
YCB3000-4T5600G	600	1415	1450	850	435	Ø14
YCB3000-4T6300G						
YCB3000-4T7200G						
YCB3000-4T8000G	1000	1415	1450	1100	465	Ø14
YCB3000-4T10000G						

RE : shell size update and size changes without additional notile,in kind shall prevail.

2.4 Wiring of the main circuit and the control circuit

2.4.1 Standard wiring diagram

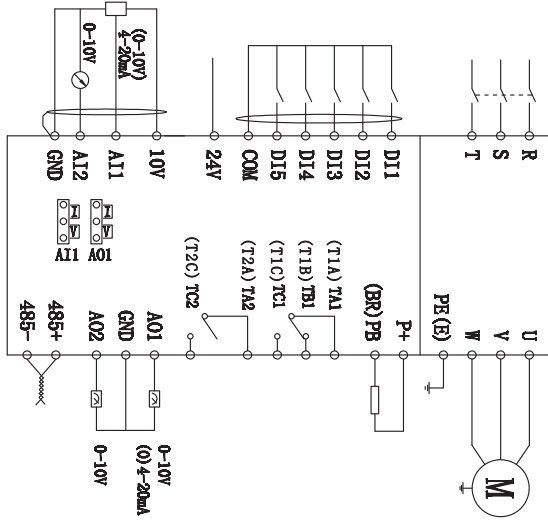

Figure 2-4 Three-phase 380V~480V /0.75-5.5kW standard wiring diagram

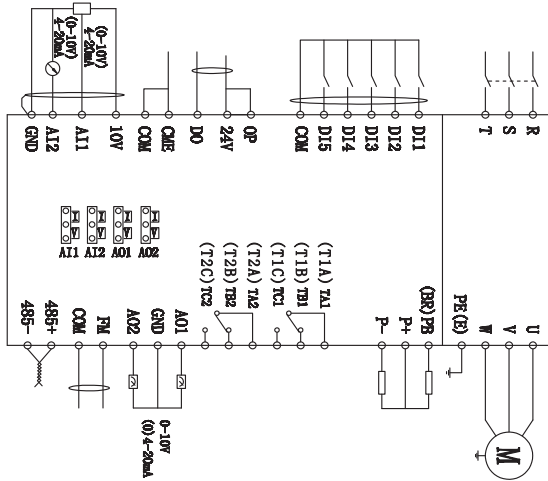
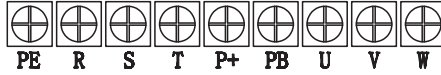

Figure 2-4 Three-phase 380V~480V /7.5-55kW standard wiring diagram

For 0.75-37KW,built-in brake unit For above 45KW,external brake unit

2.4.2 Function description and precautions of the main loop terminal

1) Main circuit terminal of YCB3000 series frequency converter



0.75KW~5.5KW main loop terminals

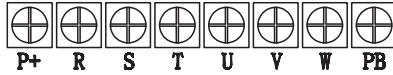

7.5KW~15KW main loop terminals

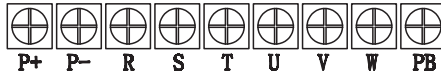

18.5KW~22KW main loop terminals

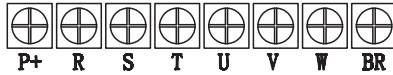

30KW~37KW main loop terminals

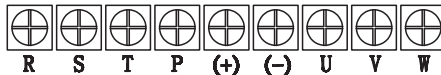

45KW~55KW main loop terminals

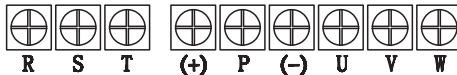

75KW main loop terminals

Terminal mark	Terminal name	function declaration
R、S、T	Three-phase power supply input terminal	AC input three-phase power connection point
(+)、(-)	Positive and negative DC bus terminals	Common DC bus input point, 37kW, and above the connection point of the external brake unit
(+)、BR (BP)	Brake resistance connection terminal	Brake resistance connections of 37kW and below
U、V、W	Frequency converter output terminal	Connect to the three-phase motor
	earth terminal (PE)	protective ground

2) Selection of the main loop cable type

Symmetrically shielded cables are recommended for the input and output main loop cables. The use of symmetrically shielded cables can reduce electromagnetic radiation throughout the conduction system, compared to four-core cables.

3) Input the power supply: R, S, and T

Input side wiring of the frequency converter, with no phase sequence requirements. Specifications and installation methods of external main loop wiring shall comply with local regulations and relevant IEC standards.

The filter shall be installed close to the input terminal of the frequency converter, and the connecting cables shall be less than 30cm. The ground terminal of the filter and the ground terminal of the frequency converter should be connected together, and ensure that the filter and the frequency converter are installed on the same conductive installation plane, which is connected to the main connection ground of the cabinet.

4) DC bus line (+), (-)

● Pay attention to the residual voltage of the DC bus (+) and (-) terminals just after the power failure, so the CHARGE light must be turned off, and the wiring operation can only be carried out after 10 minutes of power failure, otherwise there is a danger of electric shock.

- When 90kW and above choose the external brake assembly, note that (+), (-) polarity can not be reversed, otherwise cause the inverter and brake assembly damage or even fire.
- The wiring length of the brake unit shall not exceed 10m. Twair or tight double line parallel wiring shall be used.
- Can not connect the brake resistance directly to converter damage or even fire.

5) B the DC bus, which may cause frequency rake resistance connection terminals (+), BR

- The brake resistance connection terminals are valid for 30kW and below models with the built brake unit.
- The brake resistance selection value is recommended and the wiring distance shall be less than 5m. Otherwise, the inverter may be damaged.
- Note that there is no combustibile around the brake resistance. Avoid overheating of the brake resistance and igniting the surrounding devices.
- After the connects to the brake resistance, the models below 30kW and already have a built-in brake unit shall reasonably set the "P6-15" brake utilization rate and the "P9-08" brake unit action starting voltage parameters according to the actual load ;

6) U, V, and W on the output side of the frequency converter

● Wiring specification and installation of external main circuit shall comply with local regulations and relevant IEC standards.

The output side of ● converter can not be connected to the capacitor or surge absorber, otherwise the converter will be often protected or even damaged.

● When the motor cable is too long, due to the influence of the distribution capacitance, it is easy to produce electrical resonance, and cause the motor insulation damage or produce a large leakage current to make the frequency converter over current protection. When the motor cable length is greater than 100m, the AC output reactor must be installed near the frequency converter.

- The shield wire is recommended for the output motor cable. The shield layer needs to make 360° lap on the structure with the cable shield grounding bracket, and press the shield lead wire to the PE terminal.
- The lead wire of motor cable shield shall be as short as possible, and the width is not less than 1 / 5 in length.

7) Ground terminal (PE)

- The terminal must be reliably grounded and the grounding resistance must be less than $10\ \Omega$. Otherwise, the equipment will lead to abnormal operation or even damage.
- Do not share the ground terminal and the power zero line N terminals.
- Protection grounding conductors must be yellow-green cables.
- Ground position of the main circuit shield layer.
- Inverter is recommended to be installed on the conductive metal installation surface, to ensure that the whole conductive bottom of the inverter and the installation surface are good lap;
- The filter should be installed on the same installation surface with the frequency converter to ensure the filter effect of the filter.

8) Grid system requirements

This product is suitable for neutral grounding grid system, if used for IT grid system (neutral to ground insulation or high impedance grounding), need to resistor (VDR) to ground jumper and safety gauge capacitor (EMC) to ground jumper, 1 and 2 screws shown in the figure below, and the filter cannot be installed, otherwise may cause injury or damage to frequency converter.

In the configuration of leakage circuit breaker, if the leakage protection phenomenon occurs in the start, the safety gauge capacitor (EMC) can be removed from the ground jumper, and the no. 2 screw is shown in the figure below.

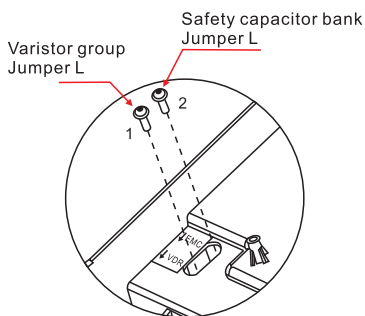
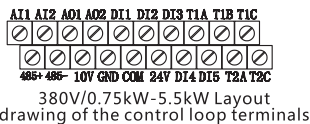

Figure 2-5-2 Location diagram of piezosistor (VDR) and gauge capacitance (EMC) to ground jumper

2.5.3 Control board

1) Control of the loop terminal distribution

Control the loop terminal arrangement



380V/7.5kW-55kW Layout drawing of the control loop terminals



7.5kW-55kW Expansion Board Features

Table 1-4 Function description of the control terminal of the YCB3000 frequency converter

class	Terminal symbol	Terminal name	function declaration
source	+10V-GND	External connection with +10V power supply	Provide +10V power supply outward, with the maximum output current: 10mA Generally used as the working power supply of the external potentiometer, the potentiometer resistance value range: 1 kΩ ~ 5k
	+24V-COM	External connection with +24V power supply	Provide the +24V external power supply, which is generally used as the digital input and output terminal working power supply and the external sensor power supply, with the maximum output current: 200mA
	OP	External power supply input terminal	The factory supply is connected to the +24V by default. When driving the DI1 to DI5 with external signals, the OP needs to be connected to the external power supply and disconnected from the +24V power supply terminal Input range: 0Vdc~10Vdc / 0mA~20mA as
imitate import	AI1-GND	Analog quantity input terminal 1	determined by the AI1 jumper selection on the control board. Input impedance: 22 kΩ at voltage input.
	AI2-GND	Analog quantity input terminal 2	Input range: 0Vdc~10Vdc / 0mA~20mA, as determined by the AI2 jumper selection on the control board. Input impedance: 22 kΩ at voltage input.
imitate output	AO1-GND	Analog output 1	The voltage or current output is determined by the AO1 jumper selection on the control board. Output voltage range: V~10V. Output current range: 0mA~20mA
	AO1-GND	Analog output 1	The voltage or current output is determined by the AO2 jumper selection on the control board. Output voltage range: 0V~10V; output current range: 0mA~20mA

class	Terminal symbol	Terminal name	function declaration
wire jumper	AI1	The AI1 input selection is made	Voltage and current input are optional, with the default voltage input
	AI2	The AI2 input selection is made	Voltage and current input are optional, with the default voltage input
	AO1	The AO1 output selection	Voltage and current output is optional, with the default voltage output
	AO2	AO2 output selection	Voltage and current output is optional, with the default voltage output
	485	RS485 Terminal Matching Resistor selection jumper	RS485 Terminal matching resistance selection
figure import	DI1	Digital input 1	Light lotus root isolation, compatible with bipolar input Input impedance: 1.39 kΩ Voltage range of effective level input: 9V~30V
	DI2	Digital input 2	
	DI3	Digital input 3	
	DI4	Digital input 4	
	DI5	High-speed pulse input terminal	In addition to the DI1. DI4. it can also be used as a high speed pulse input channel. Maximum input frequency: 100kHz; Input impedance: 1.03 kΩ
figure output	DO-CME	Digital output 1	Light lotus root isolation, bipolar open circuit collector electrode output output voltage range: 0V~24V; the output current range: 0mA~50mA Note: The digital output CME is intermall yisolated from the digital input coM, but the CME and COM are externally short-connected (the DO defaults to + 24v driver). When the DO1 wants to drive with an external power supply, the external shortcut must break the CME from the COM.
	FM-COM	High speed pulse output	Subject to the parameter P5-00 "FM Terminal Output Mode Selection" constraint; when used as a high-speed pulse output, the highest frequency is up to 100kHz; When open output as collector, as Do1 specification.
electric relay output 1	TA1 -TB1 (T1A -T1B)	Often closed terminal	Contact point drive capability: 250Vac,3A,COS=0.430Vdc, 1A
	TA1 -TC1 (T1A -T1C)	Often start	
electric relay output 2	TA2 -TB2 (T2A -T2B)	Often closed terminal	Contact point drive capability: 250Vac,3A,COS=0.430Vdc, 1A
	TA2 -TC2 (T2A -T2C)	Oftem start	

When the ambient temperature exceeds 23℃, the use amount needs to be reduced. For every 1℃ increase of the ambient temperature, the output current decreases by 1.8mA. The maximum output current at 40℃ ambient temperature is 170mA. When the user connects OP to 24V, the current of the DI terminal is also taken into account.

Chapter 3 Panel operation

3.1 Panel operation instructions

The YCB30001 series inverter can conduct parameter operation, state monitoring and control through the LED operation panel.

3.2 LED operation Panel Introduction

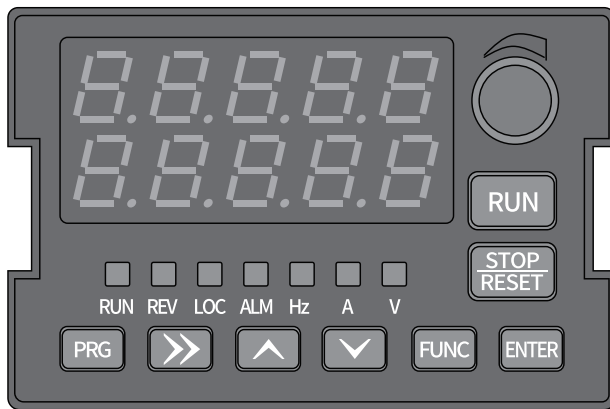

With the operation panel, the inverter can be parameter set / modified, working state monitoring, operation control (start, stop) and other operations. The appearance and operation key name of the operation panel are shown in the figure below:











Picture3-1 Operation panel



3.2.1 Function indicator light

The following table  means the light is bright,  means the lights out,  means the light flashing

Indicator lights status		State description
RUNRun the indicator light	 RUN	Light out: stop
	 RUN	Light bright: run

Indicator lights status		State description
LOCAL/REMOT Running the instruction indicator light	 LOCAL/REMOT	Light out: panel control
	 LOCAU/REMOT	Light bright: terminal control
	 LOCAU/REMOT	Light flashing: Communication control
REVPositive reversal indicator light	 REV	Light out: positive turn operation
	 REV	Light bright: reverse operation
ALM Tuned)/ torque control / fault indicator lamp	 ALM	Light out : normal operation
	 ALM	Light bright : Torque control mode
	 ALM	Light slow flash: Tuning state (1 time /s)
	 ALM	Light quick flashing : Fault state (4 times /s)

3.2.2 Keypad button function

Key	Key name	Key function
PRG	Programming key	Level 1 menu to enter or exit.
ENETER	Confirm key	Enter the menu screen step by step and confirm the setting parameters.
	Increased key	Increments of the data or parameters.
	Decreased key	Declining of the data or the parameters.
	Shiftkey	Under the shutdown display interface and the running display interface, you can then select the display parameter by a cycle, when modifying the parameter, you can select the modification bit of the parameter.
RUN	Runkey	Under the "Operation panel" start-stop control mode, used for operation.
STOP/RESET	Stop / reset	When running the state, press this key to stop the operation. This feature is restricted by the parameter P7-02, and you can reset the operation for the fault alarm state.
FUNC	Multi-function selection key	Switch between the selected functions according to the set value of P7-01

3.2.5 Parameter composition

Parameter group	Functional description	Instruction
P0~PP	Basic parameter	Operation instruction, frequency command, motor parameters, control mode, AI A/O characteristic correction, optimization control and other parameters.
A0~AC		
U0	Monitor parameter groups	Display of the basic monitoring parameters of the frequency converter

3.3 Panel tray opening dimensions

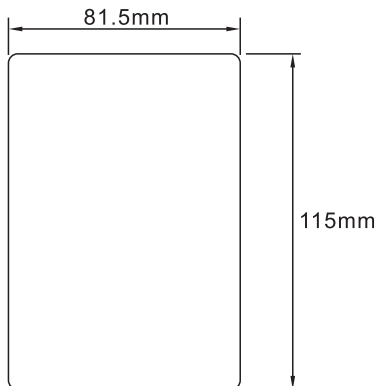

3-3 Plate tray opening dimensions diagram

Chapter 4 Functional Parameter Table

The frequency converter user password is only used to lock the panel operation. After setting the password, when reading and write through the keyboard operation parameters, they require password verification; during the communication operation (except PP, Pfgroup). The parameter menu in user custom parameter mode is not password protected.

Groups P and Group A are the basic functional parameters, while group U is the monitoring functional parameters. The symbols in the parameter table are described as follows:

"☆": indicates that the setting value of this parameter can be changed when the frequency converter is in the shutdown and running state;

"★": indicates that the set value of this parameter cannot be changed when the frequency converter is in the running state;

"●": The value of the parameter is the actual detected record value and cannot be changed;

"*": It means that the parameter is a "manufacturer parameter", which is only set by the manufacturer, and prevents users from operating;

4.1 Brief table of basic function parameters

parameter	name	Set the scope	Factory value	change
PO group Basic functional group				
P0-00	Type of Frequency inverter	1: Type G (constant torque load model) 2: P-type (fan, water pump load type)	Mo del determination	●
P0-01	The first motor control method	0: No speed sensor for vector control (SVC) 1: Speed sensor vector control (FVC) (0.75kW-5.5kW No Such Function) 2: V/ F control	2	★
P0-02	Run instruction selection	0: perating panel 1: Terminal 2: Communication	0	☆
P0-03	Main frequency instruction input select	0: Number setting (power loss memory) 1: Number setting (power memory) 2: AI1 3: AI2 4: Panel potentiometer 5: Pulse setting (D15) 6: Multiple instructions 7: Simple PLC 8: PID 9: Communication given	4	★

parameter	name	Set the scope	Factory value	change
P0-04	quenching frequency Instruction input selection	Same as P0-03 (Selection)	0	★
P0-05	Auxiliary frequency when overlaying Directive range selection	0: Relative to the maximum frequency 1: Relative to the main frequency instruction	0	☆
P0-06	Auxiliary frequency when overlaying Directive range	0%~150%	100%	☆
P0-07	Frequency instruction superposition selection	Individual bit: frequency instruction selection 0: main frequency instruction 1: Main and auxiliary operations result (operation relationship is determined by ten digits) 2: Switch between main frequency command and auxiliary frequency command 3: Switch between main frequency command and main and auxiliary operation results 4: Auxiliary frequency instruction and main and auxiliary operation result switch ten points: frequency command main and auxiliary operation relationship 0: Main + auxiliary 1: Main-auxiliary 2: Maximum value of both cases 3: Minimum value of both cases	00	☆
P0-08	Preset frequency	0.00Hz~Maximum frequency (P0-10)	50.00Hz	☆
P0-09	Running direction	0: Run in the default direction 1: Run in the opposite direction of the default direction	0	☆
P0-10	maximun-frequency	50.00Hz~500.00Hz	50.00Hz	★
P0-11	Upper limit frequency instruction selection	0: P0-12 Setting 1: AL1 2: AL2 4: Pulse setting 5: Communication given	0	★
P0-12	upper limiting frequency	Lower limit frequency P0-14 to maximum frequency P0-10	50.00Hz	☆
P0-13	Upper limit frequency bias	0.00Hz~ Maximum frequency P0-10	0.00Hz	☆
P0-14	Lower limit frequency	0.00Hz~ upper limit frequency P0-12	0.00Hz	☆
P0-15	carrier frequency	Model determination	Model determination	☆
P0-16	carrier frequency Adjust with temperature	0: No 1: Yes	1	☆

parameter	name	Set the scope	Factory value	change
P0-17	Acceleration time 1	0.00s~650.00s(P0-19=2) 0.0s~6500.0s(P0-19=1) 0s~65000s(P0-19-0)	Model determination	☆
P0-18	Slow down time 1	0.00s~650.00s(P0-19-2) 0.0s~6500.0s(P0-19=1) 0s~65000s(P0-19-0)	Model determination	☆
P0-19	Increase and deceleration time unit	0:1 Seconds 1:0.1 seconds 2:0.01 sec	1	★
P0-21	Auxiliary frequency when overlaying Instruction bias frequency	0.00Hz~Maximum frequency P0-10	0.00Hz	☆
P0-22	Frequency command resolution	2: 0.01Hz	2	★
P0-23	Number setting frequency Downtime memory choice	0: Don't remember 1: memory	0	☆
P0-24	Motor parameter group selection	0: Motor parameter group 1 1: Motor parameter group 2	0	★
P0-25	Add deceleration time reference frequency	0: Maximum frequency (P0-10) 1: Set the frequency 2: 100Hz	0	★
P0-26	Runtime frequency instruction P/DOWN benchmark	0: Run frequency 1: Set the frequency	0	★
P0-27	Run instruction bundle Main Frequency instruction selection	Individual bit: operation panel binding frequency source selection 0: No binding 1: Digital set frequency 2: AI1 3: AI2 5: Pulse setting (DI5) 6: Multi-section speed 7: Simple PLC 8:PID 9: Communication given Ten digits: Terminal binding frequency source selection 100 bits: communication binding frequency source selection	0000	☆
P0-28	Communication protocol selection	0: The Modbus protocol 1: Profibus-DP,CANopen, PROFINET, EtherCAT protocol	0	★

parameter	name	Set the scope	Factory value	change
P1_group The first motor parameter group				
P1-00	Motor type selection	0: Ordinary Asynchronous motor 1: Frequency conversion Asynchronous motor	0	★
P1-01	The motor is rated power	0.1kW~1000.0kW	Model determination	★
P1-02	The motor is rated voltage	1V~2000V	Model determination	★
P1-03	Rated current of motor	0.01A~655.35A (frequency converter power: 55KW) 0.1A~6553.5A (frequency converter power: 55KW)	Model determination	★
P1-04	Rated frequency of motor	0.01Hz~ Maximum frequency	Model determination	★
P1-05	Motor rated speed	1rpm~65535rpm	Model determination	★
P1-06	asynchronous motor stator resistance	0.001 Ω ~65.535 Ω (frequency converter power 55kW) 0.0001Ω~6.5535Ω(frequency converter power>55kw)	Tuning parameters	★
P1-07	asynchronous motor rotor resistance	0.001 Ω ~65.535 Ω (frequency converter power 55kW) 0.0001 Ω~6.5535Ω(frequency converter power>55kw)	Tuning parameters	★
P1-08	Leakresistance of asynchronous motor	0.01mH~655.35mH (frequency converter power: 55kW) 0.001mH~65.535mH (frequency converter power>55kw)	Tuning parameters	★
P1-09	asynchronous motor mutual resistance	0.1mH~6553.5mH (frequency converter power: 55kw) 0.01mH~655.35mH (frequency converter power>55kW)	Tuning parameters	★
P1-10	No load current of asynchronous motor	0.01A~P1-03(frequency converter power: 55kw) 0.1A~P1-03(frequency converter power>55kW)	Tuning parameters	★
P1-27	Number of encoder lines	1~65535	1024	★
P1-28	Encoder type	0: ABZ, the incremental encoder 2: Rotary transformer	0	★
P1-30	ABZ Incremental encoder AB phase sequence	0: Positive 1: Reverse	0	★
P1-34	Rotary transformer pole-logarithm	1~65535	1	★
P1-36	Speed feedback PG disconnection detection time	0.0s: No action 0.1s~10.0s		
P1-37	Tune selection	1:parameter tuning of asynchronous machine 2: Dynamic and complete tuning of the asynchronous machine 3: asynchronous static and complete tuning	0	★

parameter	name	Set the scope	Factory value	change
P2 group The first motor vector control parameter group				
P2-00	Speed-loop proportional gain of 1	1~100	30	☆
P2-01	The velocity loop integral time 1	0.01s~10.00s	0.50s	☆
P2-02	Switch frequency 1	0.00~P2-05	5.00Hz	☆
P2-03	Speed loop proportional gain 2	1~100	20	☆
P2-04	The velocity loop integral time2	0.01s~10.00s	1.00s	☆
P2-05	Switch frequency 2	P2-02~ maximum frequency	10.00Hz	☆
P2-06	Vector-controlled transfer gain	50%~200%	100%	☆
P2-07	SVC velocity Feedback filtering time	0.000s~0.100s	0.015s	☆
P2-09	Speed control mode under the Torque upper limit instruction selection	0: Parameter P2-10 setting 1: AI1 2: AI2 4: Pulse (DI5) 5: Communication given 6: MIN(AI1,AI2) 7: MAX(AI1,AI2) The full range of options 1-7 corresponds to P210	0	☆
P2-10	Set the torque upper limit number under the speed control mode	0.0%~200.0%	150.0%	☆
P2-11	Speed control mode under the Torque upper limit instruction selection (power generation)	0: Parameter P2-10 setting (distinction between electric and power generation) 1: AI1 2: AI2 4: PULSE pulse setting 5: Communication given 6: MIN(AI1,AI2) 7: MAX(AI1,AI2) 8: Parameter P2-12 setting The full range of options 1-7 corresponds to P2-12	0	☆
P2-12	Number limit limit setting under speed control mode (power generation)	0.0% ~ 200.0%	150.0%	☆
P2-13	excitation regulation proportional gain	0~60000	2000	☆

parameter	name	Set the scope	Factory value	change
P2-15	Torque regulation proportional gain	0~60000	2000	☆
P2-16	Torque regulation Integral gain	0~60000	1300	☆
P2-17	Speed loop integral property	Individual bit: integral separation 0: invalid 1: valid	0	☆
P2-21	The weak magnetic region is the largest moment coefficient	50~200%	100%	☆
P2-22	Power generation Limit enabling	0: invalid 1: Effective throughout the whole process 2: Effective at constant speed 3: The deceleration takes effect	0	☆
The P3 group is the V/F control parameter group				
P3-00	V/F curve setting	0: Direct Line V / F 1: Multipoint V / F 2: Square V / F 3: 1.2 Square 2: V / F 4: 1.4 Square V / F 6: 1.6 Square V / F 8: 1.8 Square V / F 9: Keep 10: V / F, completely separated mode 11: V / F semi-separation mode	0	★
P3-01	Recurrent ascension	0.0%; (Automatic Torque Lift) 0.1%~30.0%	Model determination	☆
P3-02	Torque lift stop frequency	0.00Hz~ Maximum frequency	50.00Hz	★
P3-03	Multipoint V / F, frequency point 1	0.00Hz~P3-05	0.00Hz	★
P3-04	Multi-point V / F, voltage point 1	0.0%~100.0%	0.0%	★
P3-05	Multipoint V / F, frequency point 2	P3-03~P3-07	0.00Hz	★
P3-06	Multi-point V / F, voltage point 2	0.0%~100.0%	0.0%	★
P3-07	Multipoint V / F, frequency point 3	P3-05~, Motor Rated Frequency (P1-04)	0.00Hz	★
P3-08	Multi-point V / F, voltage point 3	0.0%~100.0%	0.0%	★
P3-10	V / F overexcitation gain	0~200	64	☆
P3-11	The V/F oscillations suppress the gain	0~100	40	☆

parameter	name	Set the scope	Factory value	change
P3-13	V/F	0: Number setting (P3-14) 1: AI1 2: AI2 4: PULSE Pulse Setting (DI5) 5: Multiple instructions 6: Simple PLC 7: PID 8: Communication given Note: 100.0% corresponding to the motor rated voltage	0	☆
P3-14	Voltage for V / F separation Digital setting	0V~ Motor rated voltage	0V	☆
P3-15	Voltage for V / F separation acceleration time	0.0s~1000.0s Note: indicates the time of 0V changes to motor rated voltage	0.0s	☆
P3-16	Voltage for V / F separation deceleration time	0.0s~1000.0s Note: indicates the time of 0V changes to motor rated voltage	0.0s	☆
P3-17	V/F separation Stop mode selection	0 1: The frequency is reduced after the voltage is reduced to 0	0	☆
P3-18	Over-drain speed action current	50~200%	150%	★
P3-19	Excessive loss speed enabling	0: invalid 1: valid	1	★
P3-20	Overrain speed suppression gain	0~100	20	☆
P3-21	Compensation coefficient of action current at the excess loss speed	50~200%	50%	★
P3-22	Over-voltage stall action voltage	Three-phase 380~480V models: 30.0V~800.0V Three-phase 200~240V models: 30.0V~800.0V	★	
03-23	Overpressure stall enabling	0: invalid 1: valid	1	★
P3-24	Overpressure stall Inhibition of frequency gain	0~100	30	☆
P3-25	Overpressure stall Inhibition of voltage gain	0~100	30	☆
P3-26	Overpressure stall is the largest Increase frequency limit	0~50Hz	5Hz	★

parameter	name	Set the scope	Factory value	change
P4 group input terminal parameter group				
P4-00	D11 terminal function selection	0: No function 1: Running FWD or running command 2: Invert running REV or reverse direction 3: Three-line operation control 4: Forward rotation (FJOG) 5: Reverse movement (RJOG) 6: Terminal UP	1	★
P4-01	D12 terminal function selection	7: Terminal DOWN 8: Free parking 9: Fault reset (RESET) 10: Operation is paused 11: External fault often open input 12: Multi-segment command terminal 1 13: Multi-segment command terminal 2 14: Multi-segment command terminal 3 15: Multi-segment command terminal 4	2	★
P4-02	D13 terminal functional selection	16: Increase and deceleration time to select terminal 1 17: Increase and deceleration time to select terminal 2 18: Frequency instruction switching 19: UP / DOWN setting reset (terminal, keyboard)	3	★
P4-03	D14 terminal function selection	20: Control the command to switch over the terminal 1 21: Prohibition, acceleration and deceleration 22: The PID is paused	12	★
P4-04	D15 terminal function selection	23: Simple PLC state reset 24: Sent-out frequency pause 25: Counter input 26: Counter is reset 27: Length count input 28: Length reset 29: Torque control is prohibited 30: Pulse frequency input (valid for D15 only)	13	★
P4-05	D16 terminal function selection (Manufacturer's Parameters)	31: Keep 32: Immediately with DC braking 33: Frequent closed input for external faults 34: Frequency modification enables 35: PID, the direction of action is reversed 36: External parking terminal 1	0	★

parameter	name	Set the scope	Factory value	change
P4-06	DI7 terminal functional selection (7.5kW-55kW Expansion Board Features)	37: Control the command to switch over the terminal 2 38: The PID points are suspended 39: Switch between main frequency and preset frequency	0	★
P4-07	DI8 terminal function selection (7.5kW-55kW Expansion Board Features)	40: Switching between auxiliary frequency and preset frequency 41: Motor terminal selection function 42: Keep	0	★
P4-08	DI9 terminal function selection (7.5kW-55kW Expansion Board Features)	43: PID parameter switching 44: User-defined custom fault 1 45: User-defined custom fault 2 46: Speed control / torque control switch	0	★
P4-09	DI10 terminal function selection (Manufacturer's Parameters)	47: Emergency stop 48: External parking terminal 2 49: Slow down the DC brake 50: The operation time will be cleared to zero 51: Two line / three line switch 52: Reverse frequency is prohibited 53-59: Keep it	0	★
P4-10	DI filtering time	0.000s~1.000s	0.010s	☆
P4-11	Terminal command mode	0: Two-line type 1 1: Two-line type 2 2: Three-line type 1 3: Three-line type 2	0	★
P4-12	Terminals UP / DOWN change rate	0.001Hz/s~65.535Hz/s	1.00Hz/s	☆
P4-13	AI curve 1 minimum input	0.00V~P4-15	0.00V	☆
P4-14	The minimum input of the AI curve 1 corresponds to the setting	-100.0%~+100.0%	0.0%	☆
P4-15	AI curve 1 maximum input	P4-13~+10.00V	10.00V	☆
P4-16	The maximum input of the AI curve 1 corresponds to the setting	-100.0%~+100.0%	100.0%	☆
P4-17	The AI1 filtering time	0.00s~10.00s	0.10s	☆
P4-18	AI curve 2 minimum input	0.00V~P4-20	0.00V	☆
P4-19	The minimum input of the AI curve 2 corresponds to the setting	-100.0%~+100.0%	0.0%	☆
P4-20	AI curve 2 maximum input	P4-18~+10.00V	10.00V	☆
P4-21	The maximum input of the AI curve 2 corresponds to the setting	-100.0%~+100.0%	100.0%	☆

parameter	name	Set the scope	Factory value	change
P4-22	The AI2 filtering time	0.00s-10.00s	0.10s	☆
P4-23	AI curve 3 minimum input	-10.00V~P4-25	-10.00V	☆
P4-24	The minimum input of AI curve 3 corresponds to the setting	-100.0%~+100.0%	-100.0%	☆
P4-25	AI Curve 3 max input	P4-23~+10.00V	10.00V	☆
P4-26	The maximum input of AI curve 3 corresponds to the setting	-100.0%~+100.0%	100.0%	☆
P4-27	-	-	-	
P4-28	Pulse input minimum frequency	0.00kHz~P4-30	0.00kHz	☆
P4-29	The pulse minimum input frequency corresponds to the setting	-100.0%~100.0%	0.0%	☆
P4-30	Pulse maximum input frequency	P4-28-100.00kHz	50.00kHz	☆
P4-31	The maximum pulse-based input frequency corresponds to the set	-100.0%-100.0%	100.0%	☆
P4-32	Pulse filtering time	0.00s~10.00s	0.10s	☆
P4-33	The AI curve selection	Individual bit: AI1 curve selection 1: Curve 1 (2, point, see P4-13~P4-16) 2: Curve 2 (2, point, see P4-18~P4-21) 3: Curve 3 (2, point, see P4-23~P4-26) 4: Curve 4 (4, point, see A6-00~A6-07) 5: Curve 5 (4, point, see A6-08~A6-15) Ten places: AI2 curve selection, ibid to above	321	☆
P4-34	The AI is below the minimum input setting selection	individual bit; AI1 is below the minimum input setting Select 0: corresponding to the minimum input setting 1: 0.0% Ten digits: The AI2 is below the minimum input setting selection, ibid	000	☆
P4-35	DI1 delay time	0.0s~3600.0s	0.0s	★
P4-36	DI2 delay time	0.0s~3600.0s	0.0s	★
P4-37	DI3 delay time	0.0s~3600.0s	0.0s	★

parameter	name	Set the scope	Factory value	change
P4-38	DI terminal valid mode Choose 1	0: Effective at a high power level 1: Effective at the low level Ones: DI1 Tens: DI2 Hundreds: DI3 Thousands: DI4 Ten thousands: DI5	00000	★
P4-39	DI terminal valid mode selection 2	0: Effective at a high power level 1: Low level effective individual bit: DI6 Tens: DI7 Hundreds: DI8 Thousands: DI9 Ten thousands: DI10	00000	★
The P5 group is the output terminal parameter group				
P5-00	FM terminal output mode selection	0: Pulse output (FMP) 1: Switch volume output (FMR)	0	☆
P5-01	FMR function selection (collector open-circuit output terminal)	0: No output 1: frequency converter in operation 2: Fault output (fault for free shutdown fault) 3: Frequency level detection 1 4: Frequency arrives 5: Zero-speed operation (no output during shutdown) 06: Motor overload forecast alarm	0	☆
P5-02	Relay 1 Function Selection (TA1-TB1-TC1) (T1A-T1B-T1C)	7: frequency converter overload forecast alarm 8: Set the value arrives 9: Specify that the marked value arrives 10: Length reached 11: Simple PLC cycle is completed 12: Accumulated running time for arrival 13: Frequency limit is in the middle	1	☆
P5-03	Relay 2 function selection (TA2-TB2-TC2) (T2A-T2B-T2C)	14: Torque limit in 15: Ready to run 16: AI1>AI2 17: Upper limit frequency reaches 18: Lower limit frequency reached (no output when shutdown)	2	☆

parameter	name	Set the scope	Factory value	change
P5-04	DO output function selection	19: Underpressure state 20: Communication settings 21: Keep 22: Keep 23: Zero-speed operation 2 (also output: when shutdown) 24: Accumulated power supply time arrives 25: Frequency level detection2 26: Frequency 1 of the arrival 27: Frequency 2 of the arrival	0	☆
P5-05	Expansion card D02 output function selection	28: Current 1 arrives 29: Current 2 arrives 30: Regular arrival 31: The AI1 input is overrun 32: In the load 33: Reverse is in operation 34: Zero-current state 35: The module temperature arrives 36: Output current limit 37: Lower frequency reached (shutdown also output) 38: Warning (all faults) 39: Motor overtemperature 40: The running time arrives 41: Fault (for free shutdown fault and underpressure is not output)	4	☆
P5-06	The FMP output function selection	0: Run frequency 1: Set the frequency 2: Output current 3: Motor output torque (absolute value, percentage relative to the motor) 4: Output power 5: Output voltage 6: Pulse input (100.0% corresponding to 100.0kHz)	0	☆

parameter	name	Set the scope	Factory value	change
P5-07	A O1 output function selection	7: AI1 8: AI2 9: Panel potentiometer 10: Length 11: Remember the value 12: Communication setting 13: Motor rotation speed 14: Output current(100.0% corresponding to 1000.0A)	0	☆
P5-08	AO2 output function selection	15: Output voltage (100.0% corresponding to 1000.0V) 16: Motor output torque (actual value, percentage relative to motor) The FMP output function selection	2	☆
P5-09	FMP output maximum frequency	0.01kHz~ 100.00kHz	50.00kHz	
P5-10	AO1 zero-bias coefficient	-100.0%~ + 100.0%	0.0%	
P5-11	AO1 gain	-10.00~ +10.00	1.00	
P5-12	AO2 zero-bias coefficient	-100.0%~ + 100.0%	0.0%	
P5-13	AO2 gain	-10.00~ + 10.00	1.00	
P5-17	The FMR output delay time	0.0s~ 3600.0s	0.0s	
P5-18	RELAY1 output delay time	0.0s~ 3600.0s	0.0s	
P5-19	RELAY2 output delay time	0.0s~ 3600.0s	0.0s	
P5-20	DO output delay time	0.0s~ 3600.0s	0.0s	
P5-21	DO2 output delay time	0.0s~ 3600.0s	0.0s	
P5-22	DO Output terminal Valid State Selection	0: Positive logic 1: Antilogical unit position: FMR Ten places: RELAY1 Hundred bits: RELAY2 Thousand position: DO1 Ten thousand positions: DO2	00000	

parameter	name	Set the scope	Factory value	change
P6 group of start-stop control parameter group				
P6-00	starting mode	0: Direct start 1: Speed tracking and restart 2: Pre-excitation starts (AC asynchronous machine) 3: SVC quick start	0	☆
P6-01	Speed tracking method	0: Start with the shutdown frequency 1: Start with the power frequency 2: Start with the maximum frequency	0	★
P6-02	Speed tracking fast and slow	1~100	20	☆
P6-03	Start frequency	0.00Hz~10.00Hz	0.00Hz	☆
P6-04	Startup frequency retention time	0.0s~100.0s	0.0s	★
P6-05	Start the DC brake current / Pre-excitation current	0%~100%	50%	★
P6-06	Start the DC braking time / Pre-excitation time	0.0s~100.0s	0.0s	★
P6-07	Add deceleration mode	0: Straight-line acceleration and deceleration 1: Static S-curve 2: Dynamic S-curve acceleration and deceleration	0	★
P6-08	The S-curve start segment time scale	0.0%~(100.0%-P6-09)	30.0%	★
P6-09	The S-curve end segment time scale	0.0%~(100.0%-P6-08)	30.0%	★
P6-10	Downtime method	0: Slow down parking 1: Free parking	0	☆
P6-11	Downtime DC brake initial frequency	0.00Hz~Maximum frequency	0.00Hz	☆
P6-12	Downtime DC brake wait time	0.0s~100.0s	0.0s	☆
P6-13	Stop the DC brake current	0%~100%	50%	☆
P6-14	Stop the DC brake time	0.0s~100.0s	0.0s	☆
P6-15	Brake utilization rate	0%~100%	100%	☆
P6-18	Speed tracking current size	30%~200%	Model determination	★
P6-21	degauss time (SVC valid)	0.00~5.00s	Model determination	☆

parameter	name	Set the scope	Factory value	change
P6-23	Excessive excitation selection	0: Not effective 1: Effective with deceleration only 2: Effective throughout the whole process	0	☆
P6-24	Overexcitation suppression current value	0~150%	100%	☆
P6-25	Overexcitation gain	1.00~2.50	1.25	☆
P7 group keyboards and display parameter group				
P7-00	(Manufacturer's Parameters)			☆
P7-01	MF. K Key function selection	0: MF. K of no avail 1: The operation panel command channel switches from the remote command channel (terminal command channel or communication command channel) 2: Forward and reverse switch 3: Positive point movement 4: Reverse point movement	0	★
P7-02	STOP/RESET Key function	0: The STOP / RES key shutdown function is valid only in the keyboard operation mode 1: The STOP / RES key shutdown function is valid in any operation mode	1	☆
P7-03	LED1 runs Display parameter 1	0000~FFFF Bit00: Operating frequency 1 (Hz) Bit01: Set Frequency (Hz) Bit02: Bus line voltage (V) Bit03: Output voltage (V) Bit04: output current (A) Bit05: output power (kW) Bit06: Output torque: (%) Bit07: DI input status Bit08: DO output status Bit09: AI1 voltage (V) Bit10: AI2 voltage (V) Bit11: - Bit12: Count value Bit13: Length value Bit14: Load speed display Bit15: PID setting	1F	☆

parameter	name	Set the scope	Factory value	change
P7-04	LED1 runs Display parameter 2	0000~FFFF Bit00:PID feedback Bit01: The PLC stage Bit02: PULSE input pulse frequency kHz Bit03: Operating Frequency 2 (Hz) Bit04: remaining Bit05: AI1 Correction front Voltage(V) Bit06: AI2 Correction front Voltage (V) Bit08: Motor speed Bit09: Current Power Up Time (Hour) Bit10: Current Running Time (Min) Bit11: PULSE Input Pulse Frequency (Hz) Bit12:Communication Setpoint Bit13Encoder Feedback Speed (Hz) Bit14: Main Frequency X Display(Hz) Bit15: Auxiliary frequency Y display (Hz)	0	☆
P7-05	LED1 shutdown display parameters	0000~FFFF Bit00: Set Frequency (Hz) Bit01: Bus line voltage (V) Bit02: DI input status Bit03: DO output status Bit04: AI1 voltage (V) Bit05: AI2 voltage (V) Bit06: - Bit07: Count value Bit08: Length value Bit09: The PLC stage Bit10: Load speed Bit11: The PID setting Bit12: PULSE input pulse frequency kHz	33	☆
P7-06	Load transmission ratio	0001~65.000	2.92	☆
P7-07	Inverter module Radiator temperature	-20°C~+120°C	-	●

parameter	name	Set the scope	Factory value	change
P7-08	Product number	-	-	
P7-09	Cumulative running time	0h~65535h	-	●
P7-10	Performance version number	-	-	●
P7-11	Functional version number	-	-	●
P7-12	load speed Displays the decimal point	Individual bit: the number of decimal points of U0-14 The 0:0 decimal places The 1:1 decimal place In the 2:2 decimal places Ten places: U0-19 / U0-29 decimal points The 1:1 decimal place In the 2:2 decimal places	20	☆
P7-13	Cumulative power time	0 ~ 655 For 35 hours	-	●
P7-14	Accumulated power consumption	0 ~ 65,535 degrees	-	●
P7-17	LED2 shutdown display parameters	U0-00~U0-75	2	★
P7-18	The LED2 run display parameter	U0-00~U0-75	2	★
P8 group: Auxiliary function parameter group				
P8-00	Point movement operation frequency	0.00Hz~ Maximum frequency	2.00Hz	●
P8-01	Point motion acceleration time	0.0s~ 6500.0s	20.0s	
P8-02	Point motion deceleration time	0.0s~6500.0s	20.0s	
P8-03	Acceleration time 2	0.00s~650.00s (P0-19=2) 0.0s~6500.0s (P0-19=1) 0s~65000s (P0-19=0)	Model determination	
P8-04	Slow down time 2	0.00s~650.00s (P0-19=2) 0.0s~6500.0s (P0-19=1) 0s~65000s (P0-19=0)	Model determination	
P8-05	Acceleration time 3	0.00s~650.00s (P0-19=2) 0.0s~6500.0s (P0-19=1) 0s~65000s (P0-19=0)	Model determination	
P8-06	Slow down time 3	0.00s~650.00s (P0-19=2) 0.0s~6500.0s (P0-19=1) 0s~65000s (P0-19=0)	Model determination	
P8-07	Acceleration time 4	0.00s~650.00s (P0-19=2) 0.0s~6500.0s (P0-19=1) 0s~65000s (P0-19=0)	0.0s	

parameter	name	Set the scope	Factory value	change
P8-08	Slow down time 4	0.00s~650.00s (P0-19=2) 0.0s~6500.0s (P0-19=1) 0s~65000s (P0-19=0)	0.0s	☆
P8-09	Receive data gain (frequency)	-10.00~10.00	1.00	☆
P8-10	Jump frequency 2	0.00Hz~ Maximum frequency	0.00Hz	☆
P8-11	Jump frequency amplitude	0.00Hz~ Maximum frequency	0.00Hz	☆
P8-12	Reverse the dead zone time	0.0s~3000.0s	0.0s	☆
P8-13	Reverse frequency prohibited	0: Invalid 1: valid	0	☆
P8-14	Set the frequency is below the lower limit frequency operating mode	0: Run at the lower limit frequency 1: Downtime 2: Zero speed operation	0	☆
P8-15	The sagging rate	0.00%~100.00%	0.00%	☆
P8-16	Set the cumulative power arrival time	0h~65000h	0h	☆
P8-17	Sets the cumulative run arrival time	0h~65000h	0h	☆
P8-18	Start protection options	0: No protection 1: Protection	0	☆
P8-19	Frequency detection value of 1	0.00Hz~ Maximum frequency	50.00Hz	☆
P8-20	Frequency detection lag rate 1	0.0%~100.0%(FDT1 level)	5.0%	☆
P8-21	Frequency reaches the detection amplitude	0.0%~100.0%(Maximum frequency)	0.0%	☆
P8-22	Is the jump frequency effective during the acceleration and deceleration process	0: invalid 1: valid	0	☆
P8-25	Acceleration time 1 and acceleration time 2 switch frequency points	0.00Hz~ Maximum frequency	0.00Hz	☆
P8-26	Switch the frequency points between deceleration time 1 and deceleration time 2	0.00Hz~ Maximum frequency	0.00Hz	☆
P8-27	Terminal point motion is preferred	0: invalid 1: valid	0	☆
P8-28	Frequency detection value of 2	0.00Hz~ Maximum frequency	50.00Hz	☆
P8-29	Frequency detection lag rate 2	0.0%~100.0%(FDT2 level)	5.0%	☆
P8-30	Any arrival frequency Detection value 1	0.00Hz~ Maximum frequency	50.00Hz	☆
P8-31	Any arrival frequency Detection amplitude 1	0.0%~1000% (Maximum frequency)	0.0%	☆

parameter	name	Set the scope	Factory value	change
P8-32	Any arrival frequency Detection value 2	0.00Hz~ Maximum frequency	50.00Hz	☆
P8-33	Any arrival frequency Detection amplitude 2	0.0%~100.0%(Maximum frequency)	0.0%	☆
P8-34	Zero-current detection level	0.0%~300.0% 100.0% corresponds to the motor rated current	5.0%	☆
P8-35	Zero current detection delay time	0.01s~600.00s	0.10s	☆
P8-36	Output current limit value	0.0% (Untested) 0.1%~300.0% (rated current of the motor)	200.0%	☆
P8-37	Output current over limit Detect the delay time	0.00s~600.00s	0.00s	☆
P8-38	Any reach current 1	0.0%~3000% (rated current of the motor)	100.0%	☆
P8-39	Any arrival Current: 1 amplitude	0.0%~300.0% (rated current of the motor)	0.0%	☆
P8-40	Any reach current 2	0.0%~300.0% (rated current of the motor)	100.0%	☆
P8-41	Any arrival Current of 2 amplitude	0.0%~300.0% (rated current of the motor)	0.0%	☆
P8-42	Time function selection	0: Invalid 1: valid	0	★
P8-43	Timrunning time selection	0: P8-44 Setting 1: AI1 2: AI2 The simulated input range corresponds to P8-44	0	★
P8-44	Time running time	0.0Min~6500.0Min	0.0Min	★
P8-45	AI1 Input voltage Lower limit of protection value	0.00V~P8-46	3.10V	☆
P8-46	AI1 Input voltage Protection value upper limit	P8-45~10.00V	6.80V	☆
P8-47	Module temperature arrives	0°C~100°C	75°C	☆
P8-48	Heat dissipation fan control	0: The fan operates during operation 1: The fan is always running	0	☆
P8-49	Wake up frequency	Hibernation Frequency (P8-51)~ Maximum frequency (P0-10)	0.00Hz	☆

parameter	name	Set the scope	Factory value	change
P8-50	Wake up delay time	0.0s~6500.0s	0.0s	☆
P8-51	The dormancy frequency	0.00Hz~ Wake Up Frequency (P8-49)	0.00Hz	☆
P8-52	Sleep delay time	0.0s~6500.0s	0.0s	☆
P8-53	Arrival time of this operation	0.0~6500.0 min	0.0Min	☆
P8-54	Output power correction factor	0.00%~200.0%	100.0%	☆
P8-55	Emergency stop deceleration time	0~6553.5	Model determination	☆
The P9 group fault and protection parameter group				
P9-00	Motor overload protection selection	0: Forbidden 1: allowed	1	☆
P9-01	Motor overload protection gain	0.20~10.00	1.00	☆
P9-02	Motor overload early warning factor	50%~100%	80%	☆
P9-03	Overpressure stall gain	0~100	30	☆
P9-04	Overvoltage stall protection voltage	650V~800V	770V	☆
P9-07	Short-circuit-to-ground protection selection	Individual bit: upper power short circuit to ground protection selection 0: Invalid 1: valid Ten places: short circuit to ground protection selection before operation 0: Invalid 1: valid	01	☆
P9-08	Brake unit action starting voltage	Three-phase 380~480V models: 330.0V~800.0V Three-phase 200~240V models: 330.0V~800.0V	★	
P9-09	Number of automatic reset times of failures	0~20	0	☆
P9-10	Fault DO action selection during the automatic fault reset	0: Do not move 1: Action	0	☆
P9-11	Failure automatically reset waiting time	0.1s~100.0s	1.0s	☆
P9-12	Enter the phase absence \ contactor suction protection selection	Individual bit: Enter the missing phase protection selection 0: No input of missing phase protection 1: Protection when both software and hardware input and phase absence conditions are met 2: Protection as long as the software input missing phase conditions are met 3: Protection as long as the hardware input-phase absence conditions are met Ten places: contactor suction protection selection 0: Forbidden 1: allowed	11	☆

parameter	name	Set the scope	Factory value	change
P9-13	Lack of phase protection choice	Individual bit: Output the missing phase protection selection 0: Forbidden 1: allowed Ten digits: the output is missing phase protection selection before operation 0: Forbidden 1: allowed	01	☆
P9-14	First-time failure type	0: No fault 1: Keep 2: Accelerated overcurrent 3: Slow down the overcurrent 4: Constant-speed over-current 5: Accelerated overvoltage 6: Reduced-down overvoltage 7: Constant speed overvoltage 8: Buffer resistance to overload 9: Underpressure 10: frequency converter overload 11: Motor overload 12: Enter the missing phase 13: Output phase absence 14: The module is overheated	-	●
P9-15	Second failure type	15: External fault 16: Special communication exception 17: The Contactor is abnormal 18: Abnormal current detection 19: Abnormal motor tuning 20: Encoder / PG, card exception 21: parameter read and write exception 22: The frequency converter hardware is abnormal 23: Motor short-circuit to the ground 24: Keep 25: Keep 26: Runtime arrival 27: User-custom fault 1 28: User-custom fault 2 29: Power-on time arrives	-	●

parameter	name	Setthe scope	Factory value	
P9-16	Third-time failure type	30: Loading 31: Runtime PID feedback is lost 40: Fast flow limit timeout 41: Switch the motor during operation 42: Speed deviation is too large 43: Motor overspeed 45: Motor overtemperature 51: Initial position is incorrect 55: slave fault during main and slave control	-	●
P9-17	Third time (most recent time) Frequency of failure	0.00Hz~655.35Hz	0.00Hz	●
P9-18	Third time (most recent time) Current in case of failure	0.00A~655.35A	0.00A	●
P9-19	Third time (most recent time) Bus voltage in fault	0.0V~6553.5V	0.0V	●
P9-20	Third time (most recent time) Input terminal status on failure	0~9999	0	●
P9-21	Third time (most recent time) Output terminal status at fault	0~9999	0	●
P9-22	Third time (most recent time) Power converter status in fault	0~65535	0	●
P9-23	Third time (most recent time) Power time during failure	0s~65535s	0s	●
P9-24	Third time (most recent time) Running time on failure	0.0s~6553.5s	0.0s	●
P9-27	Frequency at the second failure	0.00Hz~655.35Hz	0.00Hz	●
P9-28	Current at the second fault	000A~655.35A	0.00A	●
P9-29	Bus voltage at the second fault	0.0V~6553.5V	0.0V	●
P9-30	When the second fault Enter terminal status	0~9999	0	●
P9-31	When the second fault Output terminal status	0~9999	0	●
P9-32	When the second fault Frequency converter state	0~65535	0	●

parameter	name	Set the scope	Factory value	change
P9-33	Power-on time during the second failure	0s~65535s	0s	●
P9-34	Run time for the second failure	0.0s~6553.5Hz	0.0s	●
P9-37	Frequency during the first failure	0.00Hz~655.35Hz	0.00Hz	●
P9-38	Current at the first fault	0.00A~65535A	0.00A	●
P9-39	Bus voltage at the first fault	0.0V~6553.5V	0.0V	●
P9-40	When the first fault Enter terminal status	0~9999	0	●
P9-41	When the first fault Output termina status	0~9999	0	●
P9-42	When the first fault Frequency converter state	0~65535	0	●
P9-43	Power-on time during the first failure	0s~65535s	0s	●
P9-44	Run time on the first failure	0.0~6553.5s	0.0s	●
P9-47	Fault protection action selection 1	Individual bit: Motor overload (Err11) 0: Free parking 1: Stop down by shutdown mode 2: Continue running Ten digit: input missing phase (Err12) Hundred bits: output phasedefault (Err13) Thousand-bit: external fault (Err15) Ten: abnormal communication (Err16)	00000	☆
P9-48	Fault protection action selection 2	Individual bit: encoder / PG card exception (Err20) 0: Free parking Ten digit: Parameter read-write exception (Err21) 0: Free parking 1: Stop down by shutdown mode Hundred bit: inverter overload fault action selection (Err10) 0: Free shutdown 1: Reduced operation Thousand bits: Motor overh eat (Err45) Ten bits: Runtime arrival (Err26)	00000	☆

parameter	name	Set the scope	Factory value	change
P9-49	error protection Action Selection 3	Individual bit: User custom fault 1 (27) 0: Free parking 1: Stop down by shutdown mode 2: Continue running Ten digit: User custom fault 2 (28) 0: Free parking 1: Stop down by shutdown mode 2: Continue running Hundred bits: power-on time arrival (29) 0: Free parking 1: Stop down by shutdown mode 2: Continue running Thousand: drop (30) 0: Free parking 1: Slow down and stop 2: Jump directly to 7% of the rated frequency of the motor to continue the operation, and automatically return to the set frequency operation when not dropped Ten: Runtime PID feedback loss (31) 0: Free parking 1: Stop down by shutdown mode 2: Continue running	00000	☆
P9-50	Fault protection action selection 4	Individual bits: excessive speed deviation (42) 0: Free parking 1: Stop down by shutdown mode 2: Continue running Ten-place: Motor overspeed (43) Hundred bits: initial position error (51)	00000	☆
P9-54	Continue running frequency selection when failure	0: Run at the current operating frequency 1: Run at a set frequency 2: Above limit frequency operation 3: Run at the lower limit frequency 4: Run at an abnormal standby frequency	0	☆
P9-55	Abnormal backup frequency	0.0%~100.0% (100.0% corresponds to the maximum frequency of P0-10)	100.0%	☆

parameter	name	Set the scope	Factory value	change
P9-56	-	-	-	☆
P9-57	-	-	-	☆
P9-58	-	-	-	☆
P9-59	Instant stop na stop function selection	0: invalid 1: Bus voltage constant control 2: Slow down 3: Power suppression	0	★
P9-60	Instant stop na stop recovery voltage	80%-100%	85%	★
P9-61	Instant stop na stop voltage recovery think time	0.0-100.0s	0.5S	★
P9-62	Instant stop na stop voltage	60%~100%	80%	★
P9-63	Loading protection options	0: invalid 1: valid	0	☆
P9-64	Drop load detection level	0.0-100.0%	10.0%	☆
P9-65	Drop load detection time	00-60.0s	1.0s	☆
P9-67	Overspeed detection value	0.0%-50.0%(Maximum frequency)	20.0%	☆
P9-68	Overspeed detection time	0.0s: Non-detection 0.1~60.0s	1.0s	☆
P9-69	Excessive velocity deviation	0.0% -50.0%(Maximum frequency)	20.0%	☆
P9-70	Too large speed deviation and too large detection time	0.0s: Non-detection 0.1~60.0s	5.0s	☆
P9-71	Instant stop no stop gain Kp	0~100	40	☆
P9-72	Instant stop no stop integral coefficient Ki	0~100	30	☆
P9-73	Instant stop no stop action and deceleration time	0-300.0s	20.0s	★
PA group The pID functional parameter group				
PA-00	PID, given the source	0: PA-01 setting 1: A11 2: A12 4: Pulse setting (Di5) 5: Communication given 6: Multiple instructions are given	0	☆

parameter	name	Set the scope	Factory value	change
PA-01	The PID values are given for the following time periods	0.0%~100.0%	50.0%	☆
PA-02	The PID, the feedback source	0: AI1 1: AI2 3: AI1-AI2 4: Pulse setting (DI5) 5: Communication given 6: AI1+AI2 7: MAX(AI1,AI2) 8: MIN(AI1,AI2)	0	☆
PA-03	PID application direction	0: Positive action 1: reverse action	0	☆
PA-04	The PID is given to the feedback range	0~65535	1000	☆
PA-05	Proportional gain of Kp1	0.0~1000.0	20.0	☆
PA-06	Integral time, TI1	0.01s~10.00s	2.00s	☆
PA-07	Differential time, Td1	0.000s~10.000s	0.000s	☆
PA-08	PID Reverse cutoff frequency	0.00~Maximum frequency	0.00Hz	☆
PA-09	The PID deviation limit	0.0%~100.0%	0.0%	☆
PA-10	PID differential limit amplitude	0.00%~100.00%	0.10%	☆
PA-11	PID given the change time	0.00~650.00s	0.00s	☆
PA-12	PID feedback filtering time	0.00~60.00s	0.00s	☆
PA-13	The PID output filtering time	0.00~60.00s	0.00s	☆
PA-14	continue to have	-	-	☆
PA-15	Proportional gain of Kp2	0~1000.0	20.0	☆
PA-16	Integration time TI2	0.01s~10.00s	2.00s	☆
PA-17	Differential time, TD2	0.000s~10.000s	0.000s	☆
PA-18	The PID parameter switching condition	0: Don't switch 1: Switch through the DI terminal 2: Automatic switch according to the deviation 3: Automatic switch according to the operating frequency	0	☆
PA-19	The PID parameter switching deviation 1	0.0%~PA-20	20.0%	☆
PA-20	The PID parameter switching deviation 2	PA-19-100.0%	80.0%	☆
PA-21	PID starter	0.0%~100.0%	0.0%	☆
PA-22	PID initial value retention time	0.00~650.00s	0.00s	☆

parameter	name	Set the scope	Factory value	change
PA-25	PID integral attribute	Individual bit: integral separation 0: Invalid 1: valid Ten digits: whether to stop the integration after the output to the limit 0: Continue the points 1: Stop the points	00	☆
PA-26	PID feedback loss detection value	0.0%: Do not judge the missing feedback 0.1%~100.0%	0.0%	☆
PA-27	The PID feedback is lost Detection time	0.0s~20.0s	0.0s	☆
PA-28	The PID shutdown operation	0: Stop and do not operate 1: Downtime operation	0	☆
PC group Multiple instructions, simple PLCparameter group				
PC-00	Multiparagraph instruction 0	-100.0%~100.0%	0.0%	☆
PC-01	Multiparagraph Directive 1	-100.0%~100.0%	0.0%	☆
PC-02	Multiparagraph Directive 2	-100.0%~100.0%	0.0%	☆
PC-03	Multiparagraph Directive 3	-100.0%~100.0%	0.0%	☆
PC-04	Multiparagraph Directive4	-100.0%~100.0%	0.0%	☆
PC-05	Multiparagraph Directive 5	-100.0%~100.0%	0.0%	☆
PC-06	Multiparagraph Directive 6	-100.0%~100.0%	0.0%	☆
PC-07	Multiparagraph Directive 7	-100.0%~100.0%	0.0%	☆
PC-08	Multiparagraph instruction 8	-100.0%~100.0%	0.0%	☆
PC-09	Multiparagraph Directive9	-100.0%~100.0%	0.0%	☆
PC-10	Multiparagraph directive 10	-100.0%~100.0%	0.0%	☆
PC-11	Multiparagraph directive 11	-100.0%~100.0%	0.0%	☆
PC-12	Multiparagraph 12	-100.0%~100.0%	0.0%	☆
PC-13	Multiple paragraph instruction 13	-100.0%~100.0%	0.0%	☆
PC-14	Multiple instructions: 14	-100.0%~100.0%	0.0%	☆
PC-15	Multiple instructions: 15	-100.0%~100.0%	0.0%	☆
PC-16	Simple PLC operation mode	0: Stop after the end of a single operation 1: Final value is maintained at the end of a single run 2: Always cycle	0	☆

parameter	name	Set the scope	Factory value	change
PC-17	Simple PLC power loss Memory choice	Individual bit: power loss memory selection 0: Do not remember the power loss 1: ELECTRIC memory Ten places: Stop memory selection 0: Stop without memory 1: Stop memory	00	☆
PC-18	Easy PLC segment 0 run time	0.0s(h)-6553.5s(h)	0.0s(h)	☆
PC-19	Simple PLC. paragraph 0 Increase and deceleration time selection	0~3	0	☆
PC-20	Simple PLC segment 1 runtime	0.0s(h)~6553.5s(h)	0.0s(h)	☆
PC-21	Paragraph 1 of the simple PLC Increase and deceleration time selection	0~3	0	☆
PC-22	Simple PLC segment 2 runtime	0.0s(h)~6553.5s(h)	0.0s(h)	☆
PC-23	Paragraph 2 of the Simple PLC Increase and deceleration time selection	0~3	0	☆
PC-24	Simple PLC segment 3 running time	0.0s(h)-6553.5s(h)	0.0s(h)	☆
PC-25	Paragraph 3 of the Simple PLC Increase and deceleration time selection	0~3	0	☆
PC-26	Simple PLC segment 4 running time	0.0s(h)-6553.5s(h)	0.0s(h)	☆
PC-27	Paragraph 4 of the Simple PLC Increase and deceleration time selection	0~3	0	☆
PC-28	Simple PLC segment 5 run time	0.0s(h)~6553.5s(h)	0.0s(h)	☆
PC-29	Paragraph 5 of the Simple PLC Increase and deceleration time selection	0~3	0	☆
PC-30	Simple PLC segment 6 running time	0.0(h)~6553.5s(h)	0.0s(h)	☆
PC-31	Paragraph 6 of the Simple PLC Increase and deceleration time selection	0~3	0	☆
PC-32	Simple PLC segment 7 runtime	0.0s(h)-6553.5s(h)	0.0s(h)	☆
PC-33	Summary PLC, paragraph 7 Increase and deceleration time selection	0~3	0	☆
PC-34	Simple PLC segment 8 running time	0.0s(h)-6553.5s(h)	0.0s(h)	☆
PC-35	Paragraph 8 of the Simple PLC increase and deceleration time selection	0~3	0	☆

parameter	name	Set the scope	Factory value	change
PC-36	Simple PLC segment 9 runtime	0.0s(h)~6553.5s(h)	0.0s(h)	☆
PC-37	Paragraph 9 of the Simple PLC Increase and deceleration time selection	0~3	0	☆
PC-38	Easy PLC segment 10 running time	0.0s(h)~ 6553.5s(h)	0.0s(h)	☆
PC-39	Paragraph 10 of the Simple PLC Increase and deceleration time selection	0~3	0	☆
PC-40	Easy PLC segment 11 running time	0.0s(h)~ 6553.5s(h)	0.0s(h)	☆
PC-41	Paragraph 11 of the Summary PLC Increase and deceleration time selection	0~3	0	☆
PC-42	Simple PLC period 12 running time	0.0s(h)~ 6553.5s(h)	0.0s(h)	☆
PC-43	Paragraph 12 of the Simple PLC Increase and deceleration time selection	0~3	0	☆
PC-44	Simple PLC Period 13 Runtime	0.0s(h)~ 6553.5s(h)	0.0s(h)	☆
PC-45	Paragraph 13 of the Summary PLC Increase and deceleration time selection	0~3	0	☆
PC-46	Simple PLC period 14 running time	0.0s(h)~ 6553.5s(h)	0.0s(h)	☆
PC-47	Paragraph 14 of the Summary PLC Increase and deceleration time selection	0~3	0	☆
PC-48	Simple PLC Period 15 Runtime	0.0s(h)~ 6553.5s(h)	0.0s(h)	☆
PC-49	Paragraph 15 of the Summary PLC Increase and deceleration time selection	0~3	0	☆
PC-50	Easy PLC running time unit	0: S (sec) 1: h (hour)	0	☆
PC-51	Multiple instruction 0 given	0: Parameter PC-00 is given 1: AI1 2: AI2 4: Pulse 5: PID 6: Given the preset frequency (P0-08), UP / DOWN can be modified	0	☆

parameter	name	Set the scope	Factory value	change
The Pd Group Communication Parameter group				
Pd-00	Communication Porter rate	Individual bit MODBUS 0: 300BPS 1: 600BPS 2: 1200BPS 3: 2400BPS 4: 4800BPS 5: 9600BPS 6: 19200BPS 7: 38400BPS 8: 57600BPS 9: 115200BPS Ten places: Profibus-DP 0: 115200Bps 1: 208300Bps 2: 256000Bps 3: 512000Bps 100 Positions: Keep Thousand bits: CANlink Porter rate 0: 20 1: 50 2: 100 3: 125 4: 250 5: 500 6: 1M	5005	☆
Pd-01	The MODBUS data format	0: No calibration (8-N-2) 1: Dual (8-E-1) 2: Strange check (8-O-1) 3: No calibration (8-N-1) (MODBUS valid)	0	☆
Pd-02	This machine address	0: Radio address 1~247 (Modbus, Profibus-DP, CANlink, Profinet, EtherCAT are valid)	1	☆
Pd-03	The MODBUS response was delayed	0-20ms (MODBUS is valid)	2	☆

parameter	name	Set the scope	Factory value	change
Pd-04	Serial port communication timeout time	0.0: invalid 0.1 ~ 60.0s(Modbus, Profibus-DP, CANopen, PROFINET, EtherCAT is valid)	0.0	☆
Pd-05	Data transfer format selection	Individual bit: Modbus 0: Non-standard Modbus protocol 1: Standard Modbus protocol Ten places: Profibus-DP CANopen, PROFINET, EtherCAT 0: PPO1 format 1: PPO2 format 2: The PPO3 format 3: PPO5 format	31	☆
Pd-06	Communication to read the current resolution	0: 0.01A (valid at ≤55kW) 1: 0.1A	0	☆
Pd-08	Profibus-DP, CANopen, Profinet, EtherCAT communication interruption detection time	The 0.0s: Invalid 0.1 ~ 60.0s	0	☆
PE group: Constant pressure water supply parameters				
PE-00	Hibernian pressure deviation	0.0~PE-04	0.0%	☆
PE-01	Sleep rate	0~10, In Unit of 5Hz / S	02	☆
PE-02	The dormancy frequency	0.00Hz~ Maximum frequency (P0-10)	2.00Hz	☆
PE-03	hold time	000.0~999.9S	2.0	☆
PE-04	Wake up stress bias	0.0~PA-01	5.0%	☆
PE-05	Wake up delay time	000.0~999.9S	0.0	☆
PE-06	Sleep reduction time	000.0~100.0S	2.0	☆
PE-07	Selection of water shortage detection method	0: No detection 1: Current mode 2: Pressure mode 3: Both are used	0	☆
PE-08	Water shortage detection pressure	0.0~PA-01	0.5%	☆
PE-09	Water shortage detection frequency	0.00Hz~ Maximum frequency (P0-10)	5.00Hz	☆
PE-10	Water shortage detection time	000.0~999.9S	5.0	☆
PE-11	Water shortage detection current	0.01 ~ Rated current of the installed model	00.01	☆

parameter	name	Set the scope	Factory value	change
PE-12	Water shortage fault is automatic Reduction interval time	001~100S	15	☆
PE-13	The PID high-limit alarm setting value	0.0%~100%	100.0	☆
PE-14	PID high-limit alarm detection time	From 000 ~200S. set to 0 without alarm	0.0	☆
PE-15	PID low-limit alarm settings	0.0%~100%	0.0	☆
PE-16	PID low-limit alarm detection time	From 000~ 200S. set to 0 without alarm	0.0	☆
PE-17	Power-on automatic run selection	0: Close 1: Turn On	0	☆
PE-18	Auto-run the latency time	00.1~100S	1.00	☆
PE-19	Anti-freezing function selection	0: Close 1: Turn On	0	☆
PE-20	Anti-freezing cycle	000~9999S, set to 0, running at antifreeze frequency	0	☆
PE-21	Anti-freezing operation time	000~9999S	60	☆
PE-22	Anti-freezing operation frequency	0.00~30.00Hz	10.00	
PP group Functional code manages the parameter group				
PP-00	User password	0~65535	0	☆
PP-01	Parameter initialization	0: No operation 01: Restore the factory parameters, excluding the motor parameters 02: Clear the record information 04: Backup the user's current parameters 501: Restore the user backup parameters	0	★
PP-02	Functional parameter group display selection	Individual bit: U group display selection 0: Do not show 1: Show Ten digits: Group A display selection 0: Do not show 1: Show	11	★
PP-03	Personality parameter group display selection	Individual bit: User-customized parameter group display selection 0: Do not show 1: Show Ten digits: User change parameter group display selection 0: Do not show 1: Show	00	★
PP-04	Parameter Modification Properties	0: Modifiable 1: Unmodifiable	0	☆

parameter	name	Minimum unit	postal address
The U0 Group Monitoring Parameter Table			
U0-00	Operating frequency (Hz)	0.01Hz	7000H
U0-01	Set Frequency (Hz)	0.01Hz	7001H
00-02	busbar voltage (V)	0.1V	7002H
U0-03	output voltage (V)	1V	7003H
U0-04	output (A)	0.01A	7004H
U0-05	Output power (kW)	0.1kW	7005H
U0-06	output torque (%)	0.1%	7006H
U0-07	DI input mode	1	7007H
U0-08	DO output state	1	7008H
U0-09	AI1 Voltage (V)	0.01V	7009H
U0-10	AI2 voltage (V) / current (mA)	0.01V/0.01mA	700AH
U0-11	AI3 voltage (V)	0.01V	700BH
U0-12	count value	1	700CH
U0-13	Length value	1	700DH
U0-14	load speed	1RPM	700EH
U0-15	PID setting	1	700FH
U0-16	PID feedback	1	7010H
U0-17	PLC stage	1	7011H
U0-18	Input pulse frequency (Hz)	0.01kHz	7012H
U0-19	Feedback speed (Hz)	0.01Hz	7013H
U0-20	The remaining running time	0.1Min	7014H
U0-21	AI1 corrected front voltage	0.001V	7015H
U0-22	AI2 pre-correction voltage (V) current mA)	0.001V/0.01mA	7016H
U0-23	-	-	-
U0-24	current mA)	1RPM	7018H
U0-25	Current power time	1Min	7019H
U0-26	Current run time	0.1Min	701AH
U0-27	Input pulse frequency	1Hz	701BH
U0-28	Communication set value	0.01%	701CH
U0-29	Encoder feedback speed	0.01Hz	701DH
U0-30	The primary frequency is shown	0.01Hz	701EH

parameter	name	Minimum unit	postal address
U0-31	Auxiliary frequency display	0.01Hz	701FH
U0-32	View any memory address values	1	7020H
U0-34	Motor temperature value	1°C	7022H
U0-35	Target torque: (%)	0.1%	7023H
U0-36	The rotation position	1	7024H
U0-37	Power factor Angle	0.1°	7025H
U0-38	ABZ position	1	7026H
U0-39	V / F separates the target voltage	1V	7027H
U0-40	V / F to separate the output voltage	1V	7028H
U0-41	The DI input status is visually displayed	1	7029H
U0-42	The DO output status is visually displayed	1	702AH
U0-43	DI function Status 1 (function 01-40)	1	702BH
U0-44	DI Function Status Visual Display 2 (Function 41-80)	1	702CH
U0-45	fault message	1	702DH
U0-58	Z event counter	1	703AH
U0-59	Set the frequency of (%)	0.01%	703BH
U0-60	running frequency (%)	0.01%	703CH
U0-61	Frequency converter state	1	703DH
U0-62	Current fault coding	1	703EH
U0-63	Point-to-point host communication sends torque values	0.01%	703FH
U0-64	Number of stations	1	7040H
U0-65	Cycle upper limit	0.1%	7041H
U0-73	Motor serial number	0: Motor 1 1: Motor 2	7049H
U0-74	Power converter output torque	0.1%	704AH
U0-76	Cumulative electricity consumption is low	0.1 Degrees	704CH
U0-77	Cumulative electricity consumption is high	1 Degrees	704DH
U0-78	linear velocity	1m/Min	704EH

Chapter 5 Fault Diagnosis and Countermeasures

5.1 Safety precautions

Safety precautions



Danger

- Never connect with power on. Please keep all circuit breakers in OFF state.



Warn

- Please ensure that the frequency converter is grounded in accordance with the local regulations. Otherwise, there will be an electric shock danger or a fire danger.
- Do not remove the housing or touch the internal circuit after the frequency converter is charged. Otherwise, there will be a danger of electric shock.
- Fault inspection must be carried out by professional personnel, and non-professional personnel are strictly prohibited to check, maintain and repair the frequency converter. Otherwise, there will be an electric shock danger or a fire danger.
- When installing the frequency converter in a closed cabinet or chassis, please use the cooling fan or cooling air conditioner to keep the inlet temperature of the frequency converter intake air below 50°C. Otherwise, it can lead to overheating or a fire.
- Please lock all the screws at the specified torque. Otherwise, there may be a fire or electric shock risk.
- Please confirm that the input voltage of the product is within the rated voltage range of the nameplate, otherwise there will be an electric shock or fire hazard.
- Do not place inflammable and explosive items near the frequency converter.



Attention

- During the installation work, please cover the upper part of the frequency converter with cloth or paper to prevent the metal chips, oil and water during drilling into the frequency converter. If the foreign body enters the frequency converter interior, it may cause the frequency converter failure.
- After the work ends, please remove the cloth or paper. If you continue to cover on the top, the ventilation will become worse, resulting in abnormal heating of the frequency converter.
- When operating the inverter, please follow the steps specified in the static electricity prevention measures (ESD), otherwise the circuit inside the inverter will be damaged due to the static electricity.

5.2 Adjustment guide for frequency converter before trial operation

1) Open-loop vector control mode (P0-01=0 factory default value)

The control mode is to control the speed and torque of the motor with no encoder speed feedback. In this control mode, motor parameters are learned to complete the automatic calibration of motor parameters.

Problems and faults	Deal with countermeasures
Overload or overload fault is reported during motor startup	<ul style="list-style-type: none"> ● Motor parameters (P1-01-P1-05) are set according to the motor nameplate. ● Motor parameter tuning (P1-37), it is best to perform motor dynamic complete tuning.
Torque or speed response below 5Hz is slow, and motor vibration occurs	<ul style="list-style-type: none"> ● To improve the response of torque and speed, strengthen the speed loop ratio adjustment (P2-00 by 10) or reduce the speed loop integration time (P2-01 by 0.05); if there is a vibration, weaken the P2-00 and increase the p2-01 parameter value.
orque or speed response above 5Hz is slow and motor yibration.	<ul style="list-style-type: none"> ● To improve the response of torque and speed, strengthen the speed loop ratio adjustment (P2-03 by 10) or reduce the speed loop integration time (P2-04 by 0.05); ● if there is a vibration, weaken the P2-03 and increase the P2-04 parameter value.
Low speed accuracy	<ul style="list-style-type: none"> ● When the motor belt load speed deviation is too large, the vector rotation difference compensation gain (P2-06) should be increased by 10%.
Fast fluctuations	<ul style="list-style-type: none"> ● When the motor speed has an abnormal fluctuation, the speed filtering time (P2-07) can be appropriately increased by 0.001s.
The motor is loud	<ul style="list-style-type: none"> ● ncrease the increasing load frequency frequency value (P0-15) by 1.0KHz appropriately; (Note: the leakage current of the increasing load frequency motor will increase)
Motor torque is insufficient or Output is not enough	<ul style="list-style-type: none"> ● Whether the torque upper limit is limited, raise the torque upper limit (P2-10) in speed mode; increase the torque instruction in torque mode

2) Closed-loop vector control mode (P0-01=1)

This mode is used in the motor with an encoder speed feedback application, and the number of encoder lines, the type of encoder and the signal direction are correctly set to complete the automatic calibration of the motor parameters.

Problems and faults	Deal with countermeasures
Start-reported overcurrent or overload fault	<ul style="list-style-type: none"> ● Set the number of encoder lines, type, and encoder direction correctly
Overload or overload fault is reported during motor rotation	<ul style="list-style-type: none"> ● Motor parameters (P1-01~P1-05) are set according to the motor nameplate. ● Motor parameter tuning (P1-37), it is best to perform motor dynamic complete tuning.

Problems and faults	Deal with countermeasures
Torque or speed response below 5Hz is slow, and motor vibration occurs	<ul style="list-style-type: none"> ● To improve the response of torque and speed, strengthen the speed loop ratio adjustment (P2-00 by 10) or reduce the speed loop integration time (P2-01 by 0.05); ● If a vibration occurs, the P2-00 and P2-01 parameters need to be weakened.
Torque or speed response above 5Hz is slow, and motor vibration.	<ul style="list-style-type: none"> ● To improve the response of torque and speed, strengthen the speed loop ratio adjustment (P2-03 by 10) or reduce the speed loop integration time (P2-04 by 0.05); ● If a vibration occurs, the P2-03 and P2-04 parameters need to be weakened.
Fast fluctuations	<ul style="list-style-type: none"> ● When the motor speed has an abnormal fluctuation, the speed filtering time (P2-07) can be appropriately increased by 0.001s.
The motor is loud	<ul style="list-style-type: none"> ● Increase the increasing load frequency frequency value (P0-15) by 1.0kHz appropriately; (Note: the leakage current of the increasing load frequency motor will increase)
Insufficient motor torque or insufficient output	<ul style="list-style-type: none"> ● Whether the torque upper limit is limited, raise the torque upper limit (P2-10) in speed mode, increase the torque instruction in torque mode

3) V/F control model (P0-01=2)

This mode is used in applications where the motor has no encoder speed feedback. It is not sensitive to the motor parameters, and only needs to correctly set the rated voltage and rated frequency value of the motor.

Problems and faults	Deal with countermeasures
Motor shock during operation	<ul style="list-style-type: none"> ● Increase the shock suppression parameters (P3-11), and increase in 10 units (the maximum adjustment to 100);
High-power start-off reports the overcurrent	<ul style="list-style-type: none"> ● Reduce the torque increase (P3-01), adjust in 0.5%;
The current is too large in the operation	<ul style="list-style-type: none"> ● Correct set the rated voltage (P1-02) and rated frequency (P1-04) of the motor; ● Reduce the torque increase (P3-01), adjust in 0.5%;
The motor is loud	<ul style="list-style-type: none"> ● Increase the increasing load frequency frequency value (P0-15) by 1.0kHz appropriately; (Note: the leakage current of the increasing load frequency motor will increase)
Sudden discharge heavy load overpressure deceleration overpressure	<ul style="list-style-type: none"> ● Confirm that the overvoltage stall enabling capacity (P3-23) is set to the enabling state; increase the overvoltage stall gain (P3-24 / P3-25, factory 30) in 10 (maximum adjustment to 100); ● Reduce the overvoltage stall action voltage (P3-22 factory 770V), reduce in 10V (minimum adjustment to 700V);
Sudden increased load current, accelerated report current	<ul style="list-style-type: none"> ● Increase the excessive loss speed gain (P3-20 factory 20), increase in 10 (maximum adjustment to 100); ● Reduce the action current of over-loss speed (P3-18 factory is 150%), and reduce it in units of 10% (minimum adjustment to 50%);

5.3 Fault alarm and countermeasures

The following fault types may be encountered during the use of the frequency converter, please refer to the following methods for simple fault analysis:

Fault name and panel display	Troubleshooting	Troubleshooting countermeasures
<p>Accelerated overcurrent</p> <p>Err02</p>	Ground or short circuit exists in the frequency converter output circuit	<ul style="list-style-type: none"> eliminates peripheral faults and detects the motor or interrupted contactor or short circuit
	Control mode is FyC or swC and No parameter identification was performed	<ul style="list-style-type: none"> Set the motor parameters according to the motor nameplate to identify the motor parameters
	Rapid acceleration condition, acceleration time setting is set too short	<ul style="list-style-type: none"> The increase the acceleration time
	Overdrain speed suppression setting is not appropriate	<ul style="list-style-type: none"> confirms that the loss speed suppression function (P3-19) is enabled; The setting value of current current (P3-18) is too large, recommended to adjust within 120% to 150%; The excessive loss speed suppression gain (P3-20) setting is too small, and it is recommended to adjust within 20 to 40;
	Manual torque lift or V/F curve is not appropriate	<ul style="list-style-type: none"> Adjust the manual lifting torque or V/F curve
	Start the rotating motor	<ul style="list-style-type: none"> Select speed tracking start or wait the motor stops before starting
	Externally disturbed	<ul style="list-style-type: none"> Check the historical fault record. If the current value is far from the overcurrent point value, find the interference source. If no other source of interference may be a drive plate or Hall device problem.
<p>Slow down over current</p> <p>Err03</p>	Ground or short circuit exists in the frequency converter output circuit	<ul style="list-style-type: none"> Troubleshoots peripheral faults and detects the motor or short circuit or open circuit
	The control mode is FwC or swC with no parameter identification	<ul style="list-style-type: none"> Set the motor parameters according to the motor nameplate to identify the motor parameters
	Rapid deceleration condition, the deceleration time is set too short	<ul style="list-style-type: none"> The increase the deceleration time
	Overcurrent speed suppression setting is not appropriate	<ul style="list-style-type: none"> confirming that the loss speed suppression function (P3-19) is enabled; The setting value of current current (P3-18) is too large, recommended to adjust within 120% to 150%; The excessive loss speed suppression gain (P3-20) setting is too small, and it is recommended to adjust within 20 to 40;
	No brake unit and brake resistance are installed	<ul style="list-style-type: none"> Equipped with the brake unit and the resistance
	Externally disturbed	<ul style="list-style-type: none"> Check the historical fault record. If the current value is far from the overcurrent point value, find the interference source. If no other source of interference may be a drive plate or Hall device problem.

Fault name and panel display	Troubleshooting	Troubleshooting countermeasures
<p>Constant speed overcurrent</p> <p>Err04</p>	Inverter output circuit exists Ground or short circuit	<ul style="list-style-type: none"> Troubleshoots peripheral faults and detects the motor for short circuit or open circuit
	The Control mode is either FVC or SVC And the parameter identification is not performed	<ul style="list-style-type: none"> Set the motor parameters according to the motor nameplate to identify the motor parameters
	Over current speed suppression setting is not appropriate	<ul style="list-style-type: none"> confirming that the loss speed suppression function (P3-19) is enabled; Setting value of current current (P3-18) is too large, recommended to adjust within 120% to 150%; Excessive loss speed suppression gain (P3-20) settings too small, and it is recommended to adjust within 20 to 40;
	The frequency converter selection is too small	<ul style="list-style-type: none"> In the stable operation state, if the operating current already exceeds the rated motor current or the rated output current value of the frequency converter, please choose the frequency converter with a larger power level
	Externally disturbed	<ul style="list-style-type: none"> Check the historical fault record. If the current value is far from the overcurrent point value, find the interference source. If no other source of interference may be a drive plate or Hall device problem.
<p>Accelerated overvoltage</p> <p>Err05</p>	The input voltage is high	<ul style="list-style-type: none"> Adjusting the voltage to the normal range
	There is an external drag during the acceleration process Motor operation	<ul style="list-style-type: none"> Cancel additional power or adds a brake resistance
	Overpressure suppression setting is not appropriate	<ul style="list-style-type: none"> Confirming that the overpressure suppression function (P3-23) has been enabled; Setting value of a voltage suppression action voltage (P3-22) is too large, and it is recommended to adjust within 770V-700V; Overpressure inhibition gain (P3-24) is too small and recommended to be adjusted within 30 to 50;
	No brake unit and brake resistance are installed	<ul style="list-style-type: none"> Equipped with the brake unit and the resistance
	The acceleration time is too short	<ul style="list-style-type: none"> Increases the acceleration time
<p>Slow down over voltage</p> <p>Err06</p>	Overpressure suppression setting is not appropriate There is an external drag during the deceleration process Motor operation	<ul style="list-style-type: none"> Confirming that the overpressure suppression function (P3-23) has been enabled; The setting value of overvoltage suppression action voltage (P3-22) is too large, and it is recommended to adjust within 770V-700V; Overpressure inhibition gain (P3-24) is too small and recommended to be adjusted within 30 to 50; Cancel additional power or adds a brake resistance
	The deceleration time is too short	<ul style="list-style-type: none"> Increase the deceleration time
	No brake unit and brake resistance are installed	<ul style="list-style-type: none"> Equipped with the brake unit and the resistance

Fault name and panel display	Troubleshooting	Troubleshooting countermeasures
Constant speed overvoltage Err07	Overpressure suppression setting is not appropriate	<ul style="list-style-type: none"> • Confirming that the overpressure suppression function (P3-23) has been enabled; • The setting value of overvoltage suppression action voltage (P3-22) is too large, and it is recommended to adjust within 770V~700V; • The overvoltage suppression frequency gain (P3-24) setting is too small, and it is recommended to be adjusted within 30 to 50; • The maximum rise frequency of overpressure suppression (P3-26) setting is set too small, and it is recommended to adjust within 5*20Hz;
	There is an external force dragging during the operation Motor operation	<ul style="list-style-type: none"> • The cancel additional power or adds a brake resistance
Buffer power fault Err08	The bus voltage fluctuates around the undervoltage point	<ul style="list-style-type: none"> • Seeks technical support
Undervoltage fault Err09	Instantaneous power failure	<ul style="list-style-type: none"> • Enables the instantaneous non-stop function (Pg-59) to prevent the instantaneous power failure
	The input voltage of the frequency converter is not as required by the specification	<ul style="list-style-type: none"> • The adjusts the voltage to the normal range
	Bus voltage is abnormal Rectifier bridge, buffer resistance, drive board, control board are abnormal	<ul style="list-style-type: none"> • Seek technical support
Inverter overload Err10	Whether the load is too large or motor blockage	<ul style="list-style-type: none"> • Reduce the load and check the motor and mechanical conditions
	The frequency converter selection is too small	<ul style="list-style-type: none"> • The uses a frequency converter with a larger power grade
Motor overload Err11	Whether the motor protection parameter P9-01 is set suitable	<ul style="list-style-type: none"> • The sets this parameter correctly
	Whether the load is too large or motor blockage	<ul style="list-style-type: none"> • Reduce the load and check the motor and mechanical conditions
Enter the missing phase Err12	Three-phase input power supply is abnormal	<ul style="list-style-type: none"> • The checks and excludes problems in the peripheral lines
	Drive plate, lightning protection plate, main control plate, rectifier bridge is abnormal	<ul style="list-style-type: none"> • Seeks technical support
output is missing phase Err13	Motor failure	<ul style="list-style-type: none"> • The detects whether the motor is in an open circuit
	The lead from the frequency converter to the motor is not normal	<ul style="list-style-type: none"> • Troubleshoots peripheral faults
	frequency converter during motor operation Three-phase output imbalance	<ul style="list-style-type: none"> • Check the three-phase winding of the motor for normal operation and troubleshooting
	Drive plate, IGBT module is abnormal	<ul style="list-style-type: none"> • seek technical support

Fault name and panel display	Troubleshooting	Troubleshooting countermeasures
The module overheating Err14	The ambient temperature is too high	• reduce the ambient temperature
	The air duct is blocked	• cleanup air duct
	Fan damage	• replacement fan
	The module thermistor is damaged	• seek manufacturer services
	The inverter module is damaged	• seek manufacturer services
External equipment failure Err15	Enter the external fault signal through the multifunctional terminal DI	• troubleshoots peripheral faults and confirms that the machinery allows a restart (P8-18), reset operation
	Enter it through the virtual I0 function Signal of an external failure	• confirm that the A1 group virtual I0 group parameters are set correctly and the reset runs
Communication fault Err16	The upper position computer is not working properly	• Check the upper position computer wiring
	The communication line is not normal	• Check the communication cable
	Communication extension card P0-28, not set correctly	• set the communication extension card type correctly
	Communication parameter P.D group is not set correctly	• set the communication parameters correctly
	After the above detection, the fault can not be eliminated, so you can try to restore the factory setting.	
contactor fault, Err17	Drive board and power supply exception	• seek manufacturer services
	Contactor anomaly	• seek manufacturer services
	Lightning protection plate abnormal	• seek manufacturer services
Current detection fault Err18	Check for Hall device abnormalities	• seek manufacturer services
	Exception of drive board	• seek manufacturer services
Motor tuning fault Err19	Motor parameters are not set according to the nameplate	• set motor parameters according to the nameplate
	The Parameter identification process has timed out	• Check the inverter to the motor leads
		• Check whether the number of encoder lines set is correct P1-27. Check whether the signal line connection of the encoder is correct and firm
Encoder fault Err20	Encoder model does not match	• set the encoder type correctly
	Encoder connection error	• detect the PG card power supply and the phase sequence
	The encoder is damaged	• Replacement Encoder
	PG card anomaly	• Replacement PG card
EEPROM Read and write fault Err21	The EEPROM chip is damaged	• seek manufacturer services

Fault name and panel display	Troubleshooting	Troubleshooting countermeasures
Short circuit to ground fault Err23	Motor short circuit to ground	<ul style="list-style-type: none"> • Replace the cable or the motor
Accumulated run time reaches thefault Err26	The cumulative running time reaches the set point	<ul style="list-style-type: none"> • use the parameter initialization function to dear the record information
User Custom Fault# 1 Err27	Enter the user-custom fault 1 signal through the multifunction terminal DI Enter a user-custom fault 1 signal through the virtual IO function	<ul style="list-style-type: none"> • reset runs • reset runs
User Custom Fault# 1 Err28	Enter the user through the multifunctional terminal DI Custom signal for fault 2 Enter the user from through the virtual IO feature Defines the signal for fault 2	<ul style="list-style-type: none"> • reset runs • reset runs
The cumulative power-up time reaches the fault Err29	The cumulative power-on time reaches the set value	<ul style="list-style-type: none"> • use the parameter initialization function to clear the record information
Loading fault Err30	The operating current of the frequency converter is less than P9-64	<ul style="list-style-type: none"> • confirm whether the load is detached or whether the P9-64 and P9-65 parameter settings meet the actual operating conditions
Runtime PID feedback lost fault Err31	The PID feedback is less than the PA-26 Setpoint	<ul style="list-style-type: none"> • check the PID feedback signal or sets PA-26 to an suitable value
PID low-limit alarm Err32	The PID feedback is less than the P E-15 setting value	<ul style="list-style-type: none"> • set the PE-15 to a suitable value
PID high limit alarm Err33	The PID feedback is greater than the P E-13 settings	<ul style="list-style-type: none"> • set the PE-13 to a suitable value
Water shortage alarm Err34	The operating frequency is higher than PE-09and thefeedback pressure is lower than PE-08	<ul style="list-style-type: none"> • set PE-08 and PE-11 to a suitable value
Wave wave limiting fault Err40	Whether the load is toolarge or motor blockage	<ul style="list-style-type: none"> • Reduce the load and check the motor and mechanical conditions
	The frequency converter selection is too small	<ul style="list-style-type: none"> • use a frequency converter with a larger power grade

5.4 Common faults and handling methods

order number	fault phenomenon	Possible cause	processing method
1	The upper power is not shown	The grid voltage is not present or is too low	● Check for the input power supply
		Switch power failure on frequency converter drive panel	● Check whether the 24V and 10V output voltage on the control board is normal
		The connection between the control board and the drive board and the keyboard is disconnected	● replug 8-core and 34-core wiring
		The frequency converter buffer resistance is damaged	● seek manufacturer services
		Control board, keyboard failure	
The rectifier bridge is damaged			
2	The upper power is always displayed -A-C-	The connection contact between the drive plate and the control board is poor	● replug 8-and 28-core wiring
		Related devices on the control board are damaged	● seek manufacturer services
		The motor or motor wire has a short circuit to the ground	
		Hall fault	
		The power grid voltage is too low	

order number	fault phenomenon	Possible cause	processing method
3	On the display Police show Err 23	Motor ar output line is short-circuit to ground	● measure the insulation of the motor and output lines with a shake meter
		Frequency converter damage	● seek manufacturer services
4	The electric frequency converter is normal and displayed after operation -A-C- And shut down immediately	The fan is damaged or blocked	● replacement fan
5	Frequent reporting of Err14 (module overheating) fault Err 14	The load frequency setting is too high	● load frequency reduction (PO-15)
6	Motor after frequency converter operation Do not turn	Damaged fan or blocked air duct	● Replace the fan and clean up the air duct
		Damaged fan or blocked air duct	● Replace the fan and clean up the air duct
		Internal inverter device damage (thermistor or other)	● seek manufacturer services
		Poor contact between drive board and control board	● replug the cable, confirm that the wiring is firm;
		Drive board failure	● seeks manufacturer services
7	DI terminal failure	Parameter setting error	The ● checks for and resets the p 4 group-related parameters
		External signal error	● reconnects to the external signal line
		OP and + 24v, loose jumper	● reconfirms the Op with the + 24V jumper and ensures fastening.
		Control board failure	● seek manufacturer services
8	Motor speed cannot be increased during closed-loop vector control	Encoder failure	● Replace the code tray and reconfirm the wiring
		The encoder has the wrong wire or poor contact	● rewiring to ensure good contact
9	The frequency converter frequently reports the overcurrent and overvoltage faults	Motor parameters are not set correctly	● to reset the motor parameters or perform motor tuning
		Increase and deceleration time is not appropriate	● set the appropriate acceleration and deceleration time
		fluctuation of load	● seek manufacturer services
10	power on (Or run) To Err17	The soft-start contactor is not engaged	<ul style="list-style-type: none"> ● Check whether the contactor cable is loose ● Check the contactor for a fault ● Check the contactor 24v power supply for a fault ● seeks manufacturer services

V/F curve running mode according

When inverter drives reduced torque load such as fans, and pumps, user can select 1/2/3 V/F curve running mode according to load characteristic for energy saving.

P3.00=0,(3,4,6,8) Customized V/F curve shown as Fig. 6-1.

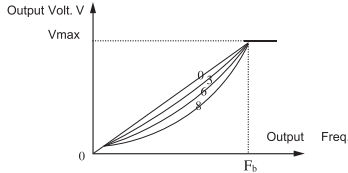

Vmax: max output voltage Fb basic running Freq.

Fig 6-1 customized V/Fcurve

P3.00=1, Customized V/F curve shown as Fig. 6-2.

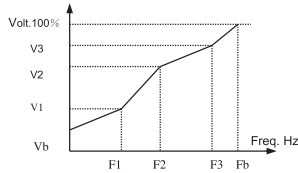

Fig 6-2 customized V/Fcurve

User can define V/F curve through revising (V1,F1),(V2,F2),(V3,F3) so as to meet special load requirements. Torque boost is available for customized curve.

P3.03~P3.08 define multiple V/F curves with six parameters.

The curve of multi-point V/F should be set according to the load characteristics of the motor. It should be noted that the relationship between the three voltage points and frequency points must meet the following requirements: $V1 < V2 < V3$, $F1 < F2 < F3$. Figure 6-2 is a schematic diagram for setting the multi-point VF curve

Setting the voltage too high at low frequencies may cause the motor to overheat or even burn out, and the frequency converter may experience overcurrent stall or overcurrent protection.

Set the main frequency by "analog"

The relationship between AI1, AI2 and setting frequency is as follow.

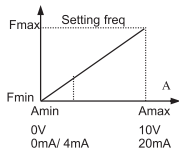

Amin : min given Fmin : Corresponding freq to min given
 Amax : max given Fmax : Corresponding freq to max given

Fig 6-3 customized V/Fcurve



CERTIFICATE

Product Model: YCB3000 Series

Standard: IEC 60947-4

Inspector : CNC 003

Production date: Printed on the product
or package.

This product is qualified according
to the delivery inspection

A vertical red bar containing the white text 'CNC' in a bold, sans-serif font, oriented vertically.

YCB3000 Series

CNC ELECTRIC

Tel: 0086-577-61989999 Fax: 0086-577-61891122

wwwcncele.com E-mail: cncele@cncele.com