

**DELIVER  
POWER  
FOR  
BETTER LIFE!**

# CATALOGUE

## SWITCHGEAR& SUBSTATION



**CNC**  
ELECTRIC

**CNC ELECTRIC GROUP ZHEJIANG TECHNOLOGY CO.,LTD**

● Add : CNC High-Tech Hutou Industrial Zone, Liushi Town, Yueqing · Wenzhou City, China  
● Tel : 0086-577-6289 8809 ● Web : www.cncele.com ● Fax : 0086-577-6189 1122

CNC ELECTRIC

printed on recycled paper



This manual is printed by CNC ELECTRIC GROUP CO., LTD, only used to show the relative information of this series. CNC ELECTRIC GROUP CO., LTD keep the right of amending this manual due to technical improved or new production process used, or mistake amended, etc without notice. Please contact with our company to confirm the relative information when place the order.

**CNC**  
ELECTRIC

# About CNC

CNC was founded in 1988 specialized in Low-voltage electrical and Power Transmission and Distribution industries. We provide our customers with profitable growth by offering integrated comprehensive electrical solution.

CNC key value is innovation and quality to ensure clients with safe, reliable products. We set up advanced assembly line, test center, R&D Center and quality control center. We have got the certificates of ISO9001, ISO14001, OHSAS18001 and CE, CB, SEMKO, KEMA, TUV etc.

As a leading manufacturer of electrical products in China, our business covers over 100 countries.

**DELIVER  
POWER  
FOR  
BETTER LIFE!**



# CONTENTS

## Prefabricated Substation

02-13

YBM22-12/0.4	Outdoor Prefabricated Substation (EU)	Page 02~07
YB27-12/0.4	Outdoor Prefabricated Substation ( US)	Page 08~13

## Medium Voltage Switchgear

15-86

KYN61-40.5	Metalclad AC Enclosed Switchgear, Withdrawable Type	Page 15~20
KYN28-24	Metalclad AC Enclosed Switchgear, Withdrawable Type	Page 21~24
KYN28-12	Metalclad AC Enclosed Switchgear, Withdrawable Type	Page 25~34
XGN15-12~24	Air-insulated RMU(Fixed Type)	Page 35~41
YSM6-12~24	Air-insulated RMU(Fixed Type)	Page 42~50
HXGN15A-12	Air-insulated RMU(Fixed Type)	Page 51~58
YVG-12	Solid Insulation Ring Network Cabinet	Page 59~63
YRM6-12~24	Gas-insulated Metal-enclosed Switchgear	Page 64~86
YRM6-40.5	SF6 Gas Insulated Metal Enclosed Switchgear	Page 87~90
YGH-12	Environmentally Friendly Gas-insulated Ring Main Unit	Page 91~99

## Low Voltage Switchgear

88-122

GGD	Low Voltage Power Distribution Cabinet	Page 102~105
GCS	Low voltage Switchgear Panel, Withdrawable Type	Page 106~116
GCK	Low voltage Switchgear Panel, Withdrawable Type	Page 117~125
MNS	Low voltage Switchgear Panel, Withdrawable Type	Page 126~129
XL	Low Voltage Power Distribution Cabinet	Page 130~132
JXF	Low Voltage Integrated Distribution Box	Page 133~134

# Our Advantages

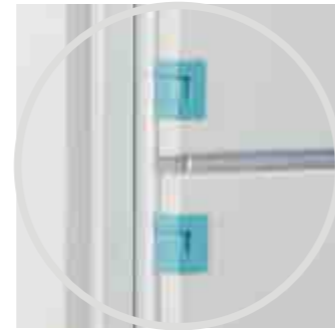

The angle of normal hinge is 90°, while this hinge can ensure the angle of 180° when opening the door.



Tinning, leading angle, deburring and knurling at tap joint to all busbars, degrade the resistant of lap.

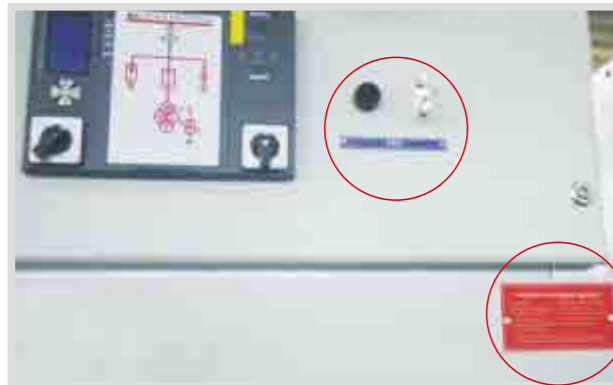

Add the switchgear operate stipulation and the points for attention to prevent error operating.

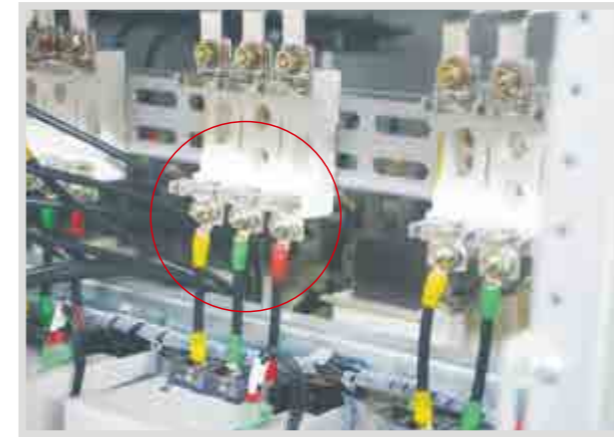

Adopt the dedicated machine to make the cable lug, ensure the reliability of cable lug and reduce the situation like cable lug fall off, lap resistance too big and virtual connection.



The frame adopts C type material, intensified the frame strength and decreased the error of connecting between each cabinet, better commonality, more convenient to install and maintain electrical components.



# Prefabricated Substation



POWER TRANSMISSION AND  
DISTRIBUTION PRODUCT SELECTION

PROFESSIONAL MANUFACTURER OF  
HIGH AND LOW VOLTAGE PRODUCTS

**CNC**  
ELECTRIC

## Prefabricated Substation

### YBM22-12/0.4 Outdoor Prefabricated Substation (EU)

Rating:

Rated voltage: HV equipment 7.2KV and 12KV, LV equipment 0.4 KV. Rated current: HV equipment 630A, LV equipment 100-2000A. Application: YBM22 series substation is a kind of compact power distribution device that integrates high and low voltage electrical equipment. It can be used in high-rise buildings, buildings in urban and rural areas, residential communities, high-tech development areas, small and medium size factories, mining areas, oil fields, temporary features sites, and other premises. It also can be used for acceptance and distribution of power in power distribution system of 6-15KV, 50HZ(60HZ), ring main power distribution system and double power supply or radiate terminal power distribution system.

Feature:

High integrity, small size, compact structure, safe and reliable operation, convenient maintenance, portable, etc. Compared with conventional civil engineering substation, in the same capacity, the prefabricated combined substation need only 1/10~1/15 floor area, so that the features expense is reduced.

Standard: IEC1330

General



**CNC**  
ELECTRIC

## Prefabricated Substation

### YBM22-12/0.4 Outdoor Prefabricated Substation (EU)

#### Selection

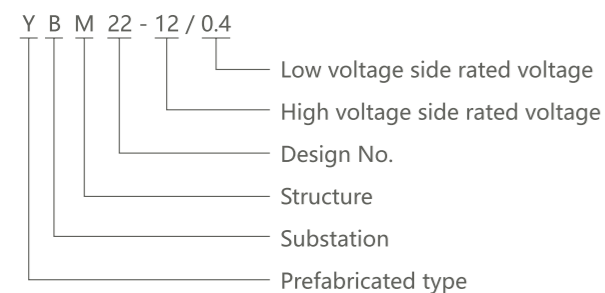

#### Operating conditions

1. Ambient air temperature: -10°C~+40°C
2. Altitude: ≤1000m
3. Solar radiation: ≤1000W/m<sup>2</sup>
4. Ice cover: ≤20mm
5. Wind speed: ≤35m/s
6. Relative humidity: Daily average relative humidity≤95%.Monthly average relative humidity≤90%  
Daily average relative water vapour pressure ≤2.2kPa. Monthly average relative water vapour pressure ≤1.8kPa
7. Earthquake intensity: ≤magnitude 8
8. Applicable in the places without corrosive and flammable gas

Note: Customized products are available

#### Features

1. The product is connected together by high voltage power distribution equipment,transformer and low voltage power distribution device. And divided into three functional compartments, that is High voltage compartment, Power transformer compartment and Low voltage compartment, have completely HV, LV function.High voltage side of a power supply system, can be arranged in a ring network power supply, end user power supply, dual power supply and other power supply, also can be provided with the high-voltage metering device to meet high voltage measurement. Transformer room can choose S9, SC and other series of low loss of oil immersed transformer or dry type transformer; low voltage chamber can be panel or cabinet mounted structure based on user requirement to form the power supply scheme required by user. These are power distribution,lighting distribution, Static Var Compensator, energy metering and energy measurement and other function, to meet different requirement of user. This make Power management convenient for users and improve the quality of power supply.
2. The high voltage chamber with compact and reasonable structure,has a comprehensive anti mis-operation interlock function. It can be equipped with a rail for power transformer when it is required by customer, it can make transformer in and out conveniently in power transformer compartment. Each room has the automatic lighting device, Meanwhile, all elements in high voltage and low voltage cabinet are reliable performance, convenient operation.
3. Adopt natural ventilation and the forced ventilation in two ways.There is ventilation channel for power transformer compartment and High, Low voltage compartment. The exhaust fan is provided with a temperature control device, it can automatic startup and shutdown according to the setting temperature.This ensure the normal operation of transformer.
4. The enclosure structure can prevent rain and dirt. The material adopt color steel plate and have anti-corrosion insulation function.

## Prefabricated Substation

### YBM22-12/0.4 Outdoor Prefabricated Substation (EU)

Sheet 1

#### Technical data

Item	Unit	H.V electrical equipment	Transformer	L.V electrical equipment
Rated voltage	kV	10	10/0.4	0.4
Rated current	A	630	/	100~2500
Rated frequency	Hz	50	50	50
Rated capacity	kVA		100~1250	
Rated thermal stability current	kA	20/4S	/	30/1S
Rated dynamic stability current (peak)	kA	50	/	63
Rated closing short-circuit current (peak)	kA	50	/	15~30
Rated breaking short circuit current	kA	31.5 (Fuse)	/	/
Rated breaking load current	A	630	/	/
1 min power frequency withstand voltage	kV	Between phases, to earth 42, to open contacts 48	35/28(5min)	20/2.5
Lightning impulse withstand voltage	kV	Between phases, to earth 75, to open contacts 85	75	/
Shell protection class		IP23	IP23	IP23
Noise level	dB	630	Oil transformer≤55 Dry transformer≤65	/
Loops No.		/	2	4~30
Low voltage side max static var compensator	kvar	/	/	300

#### Overall and mounting overall and mounting dimensions(mm) s(mm)

YBM series of prefabricated substation have type 1 (refer pic1-1, 1-2) and type 2 (refer to 1-3, 1-4), the Overall and mounting dimensions(mm) s refer to pic 2, pic 3.

YBM series of prefabricated substation plane layout

Picture 1

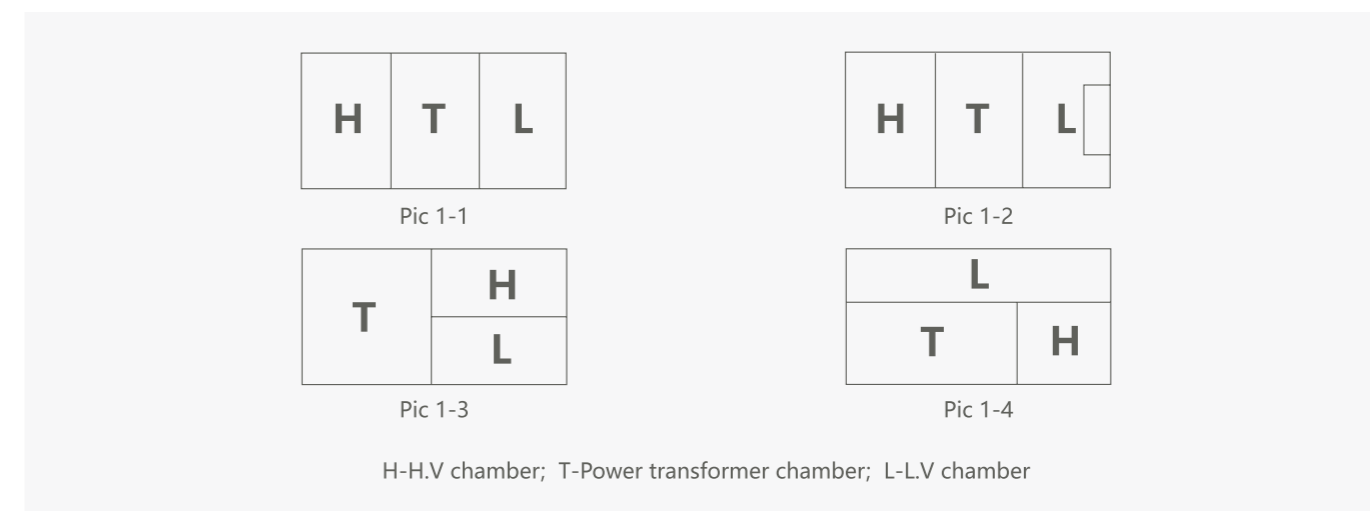

# Prefabricated Substation

## YBM22-12/0.4 Outdoor Prefabricated Substation (EU)

Type 1 layout

Picture 2

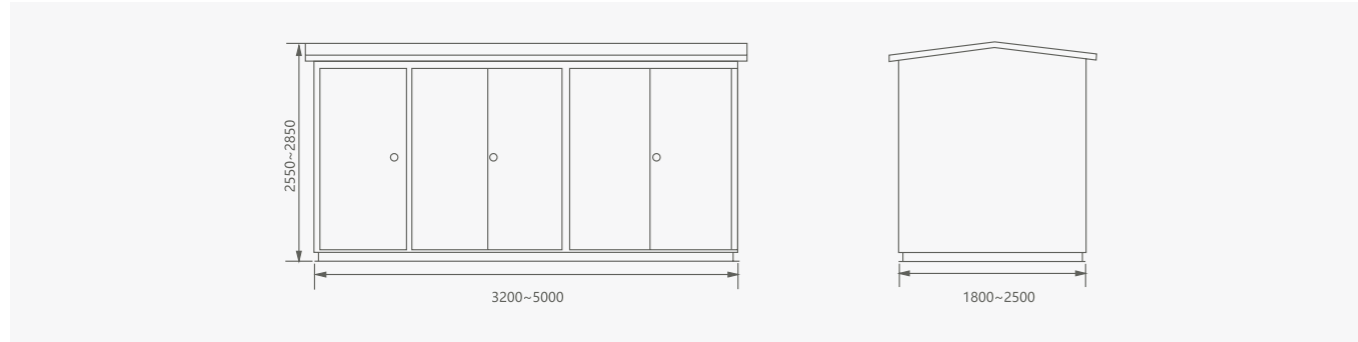

Type 2 layout

Picture 3

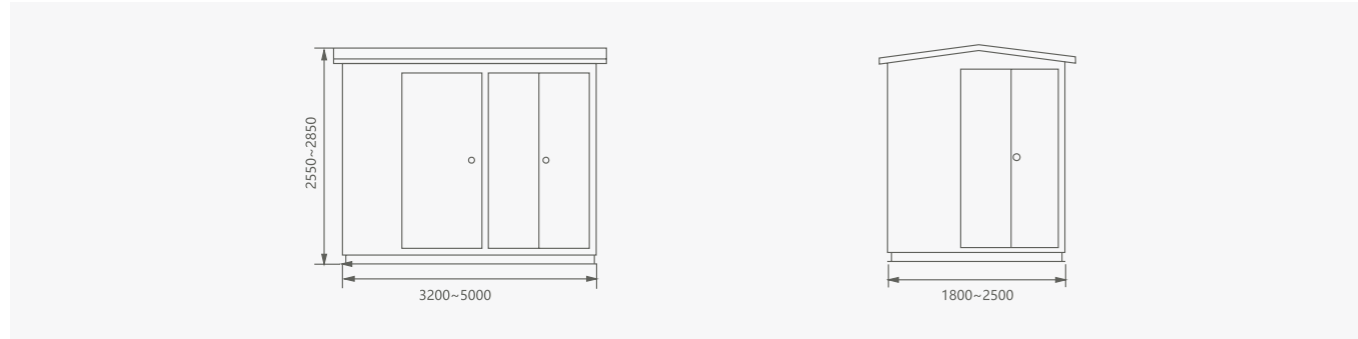

### Foundation drawing

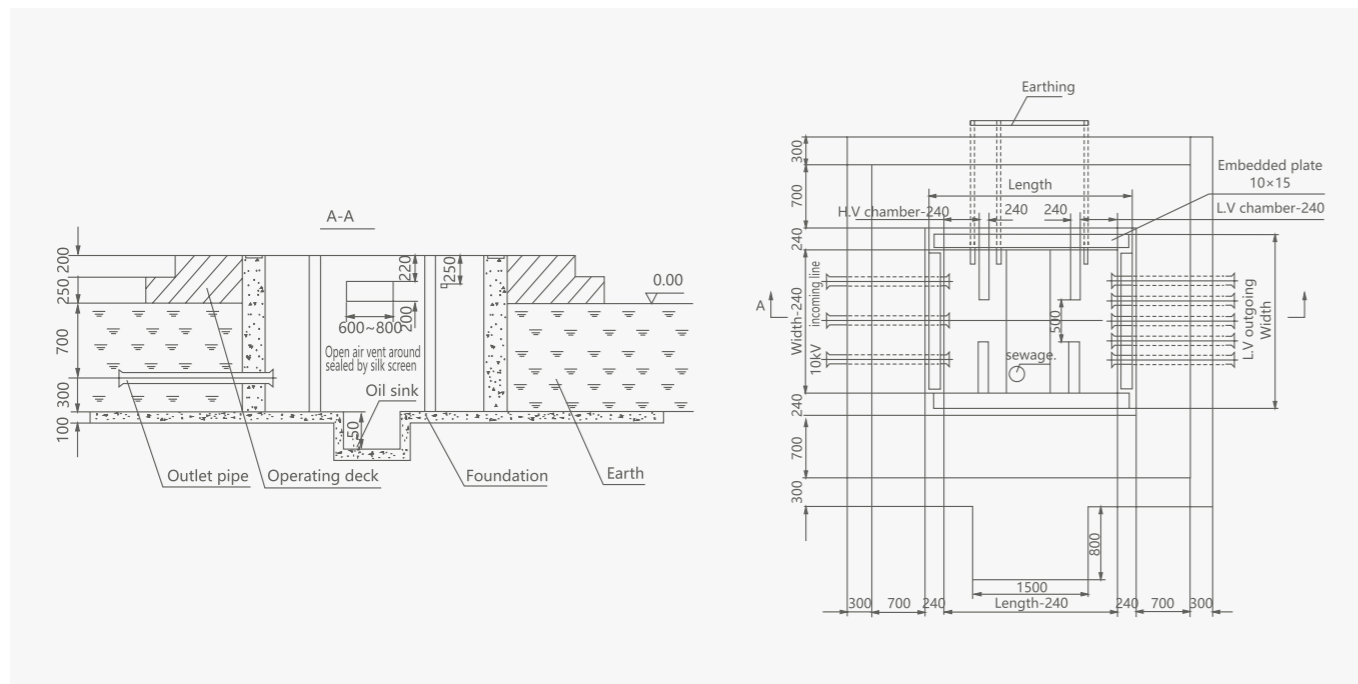

# Prefabricated Substation

## YBM22-12/0.4 Outdoor Prefabricated Substation (EU)

### Main single line diagram

High voltage loop scheme

Sheet 1

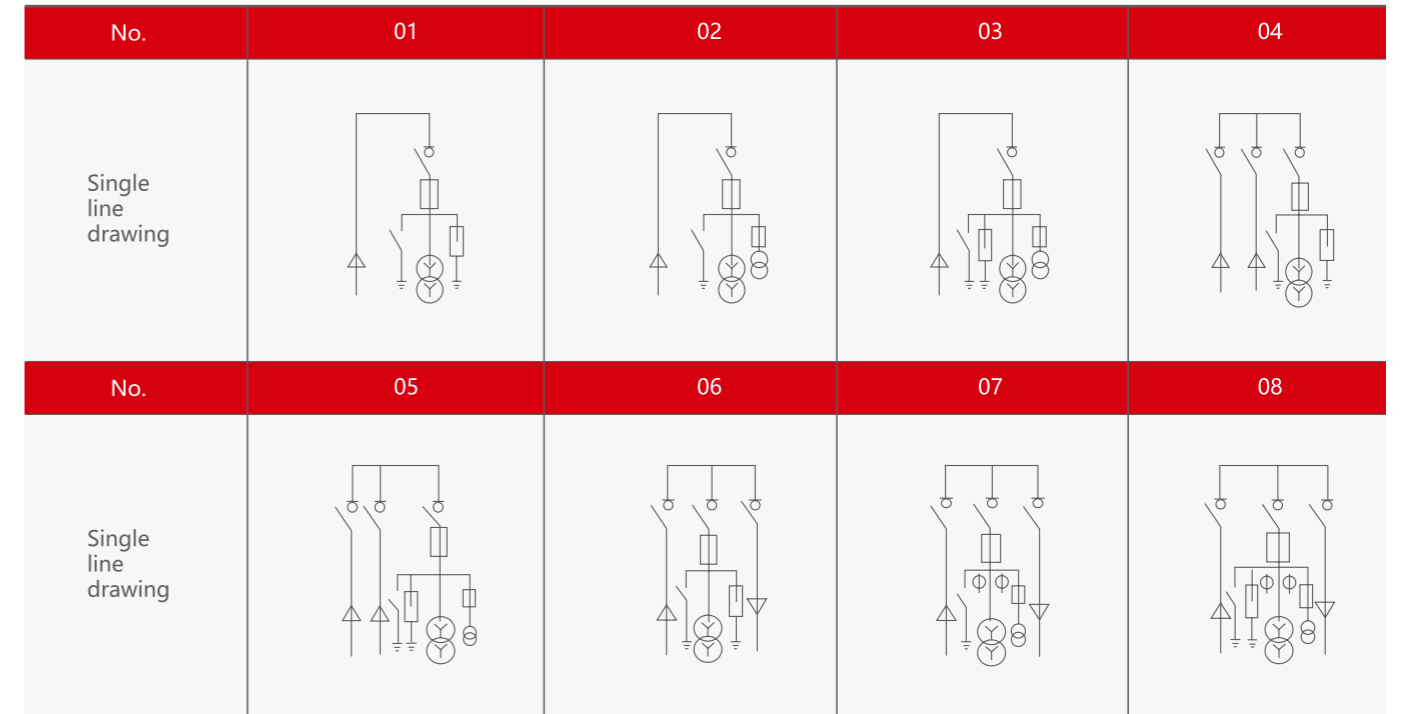

Low voltage loop scheme

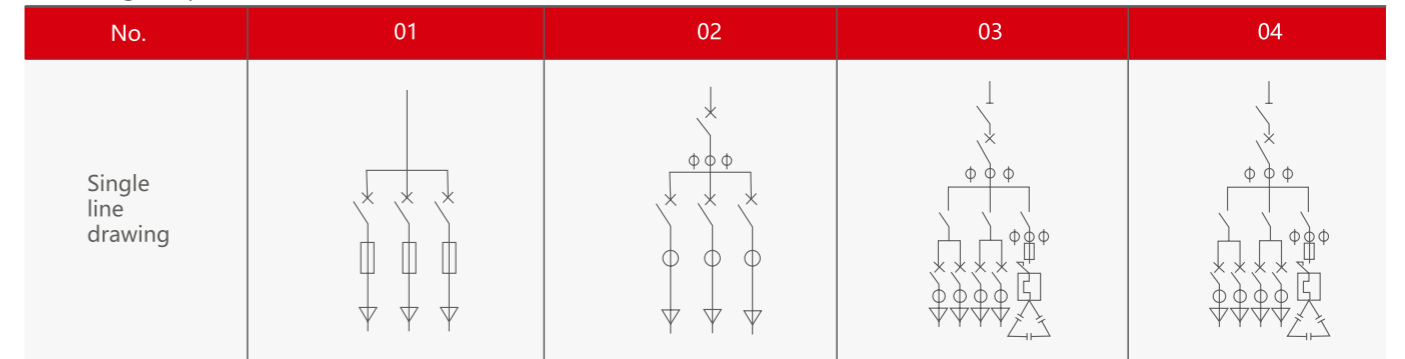

### The typical scheme for example

Terminal low measurement

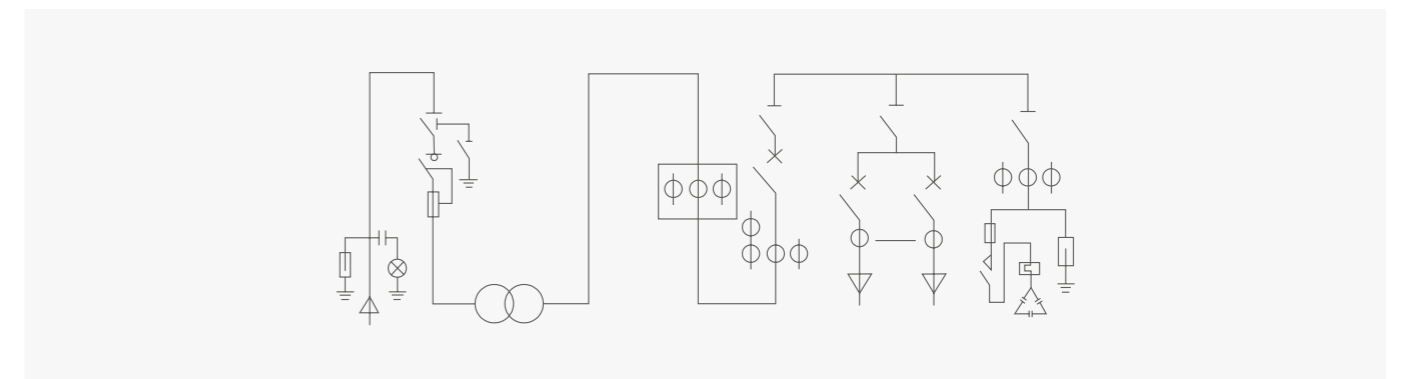

## Prefabricated Substation

### YBM22-12/0.4 Outdoor Prefabricated Substation (EU)

Terminal high measurement

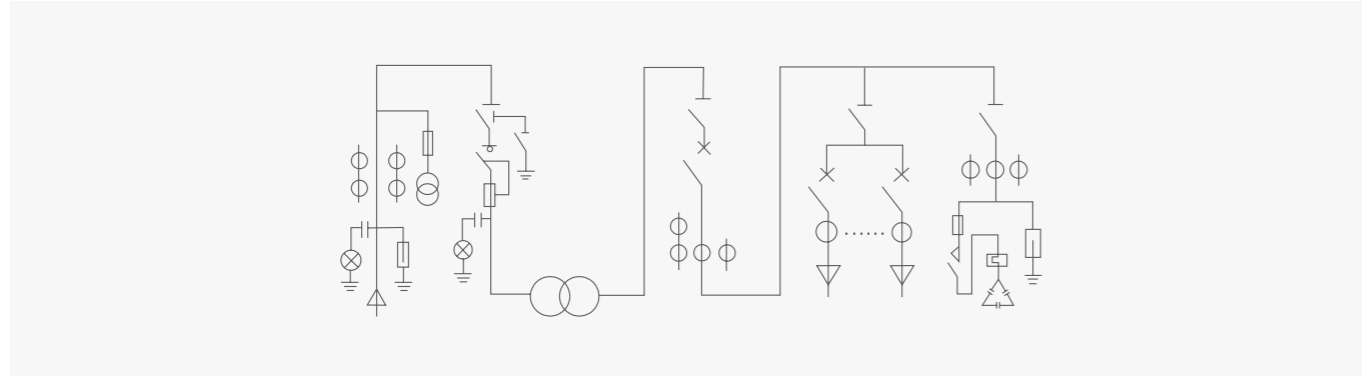

Looped network Low measurement

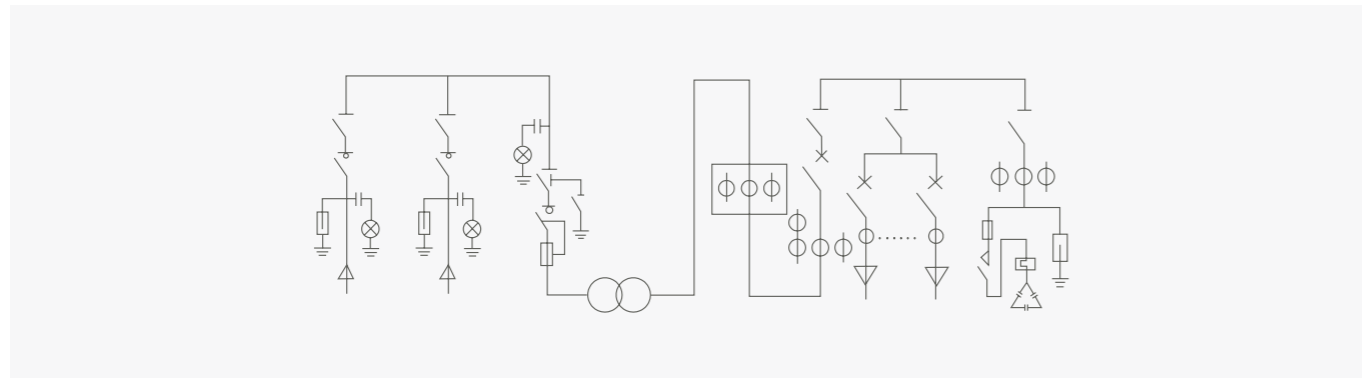

Looped network high measurement

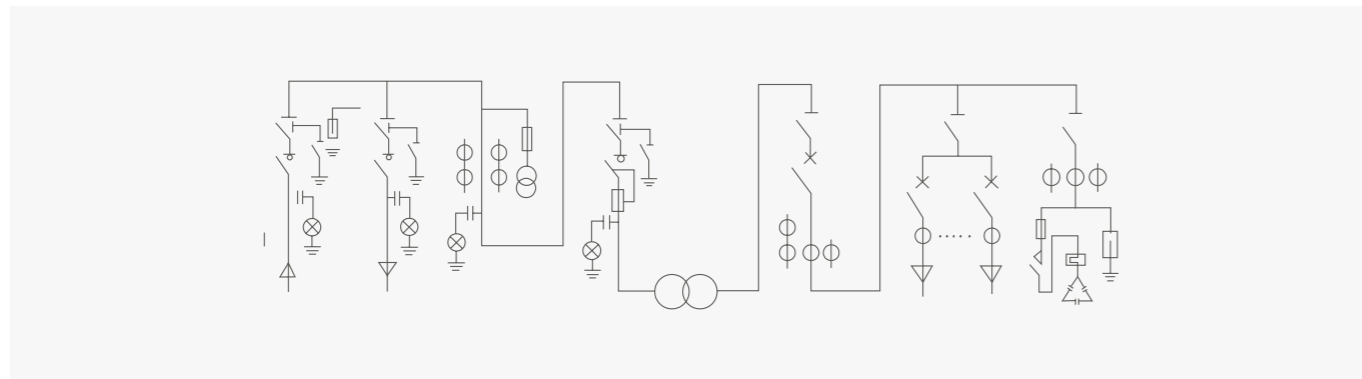

#### Please provide the following information when ordering

1. The type of prefabricated substation
2. The type and capacity of power transformer
3. High voltage and low voltage single line scheme
4. Electrical component models and parameters if have special requirement
5. Shell color
6. The spare parts, name, quantity and other requirements

## Prefabricated Substation

### YB27-12/0.4 Outdoor Prefabricated Substation (US)

#### Rating:

Rated voltage : HV equipment 10KV and 12KV, LV equipment 0.4 KV. Rated current : HV equipment 630A, LV equipment 1500A.

#### Application:

Yb27 series substation is an American type combined substation with function of high voltage control, protection, power transformation and distribution. Usually used in urban and rural power distribution system. The high voltage load switch and high voltage fuse of this product are installed in the oil of the transformer, with the two structures: in same case with the transformer and in different case with transformer. It can be used in high-rise buildings, building in urban and rural areas, residential communities, high-tech development areas, small and medium size factories, mining areas, oil fields, temporary features sites, and other premises.

Standard: IEC1330

**General**



## Prefabricated Substation

### YB27-12/0.4 Outdoor Prefabricated Substation (US)

#### Selection

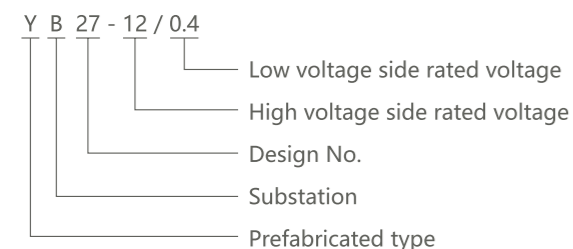

#### Operating conditions

1. Ambient air temperature: -30°C~+40°C
2. Altitude: ≤1000m
3. Wind speed: 34m/s ≤700pa
4. Relative humidity: Daily average relative humidity ≤95%. Monthly average relative humidity ≤95%.
5. Installation inclination: ≤grade 8
6. Applicable in the places without corrosive and flammable gas.

Note: Customized products are available.

#### Features

1. Compact structure with small volume, the volume is 1/3-1/5 of European style substation in same capacity. It reduce the floor space efficiently.
2. Whole sealing and full insulated structure ,no need insulation distance. This can protect personal safety
3. High voltage wiring can used both in looped network and terminal with high reliability and flexibility
4. The transformer is with excellence performance, low loss, low Noise, low temperature rise, high overload capacity, strong impact resistant ability and high anti-short circuit capacity .
5. connector. Both can equipped with all insulated ZnO lightning conductor. 200A elbow connector can use with load plug and with the function of insulation switch.

#### Technical data

1. Rated voltage: 10kV/0.4kV
2. High voltage side rated voltage: 10kV
3. High voltage side max voltage: 12kV
4. Low voltage side rated voltage: 0.4kV
5. Rated frequency: 50Hz
6. High voltage switch thermal stability capacity: 20kA/26
7. Low voltage main circuit breaker rated short circuit breaker capacity: 35kA
8. Low voltage output circuit breaker rated short circuit breaker capacity: 35kA
9. High voltage load switch transfer current: 1500A
10. Selection of neutral earthing bus

## Prefabricated Substation

### YB27-12/0.4 Outdoor Prefabricated Substation (US)

#### Technical data

Rated voltage (kV)	10			0.4
	Transformer	Switch to ground and interphase	Switch isolation between fracture	
Power frequency withstand voltage(kV)	35	42	48	2.5
The peak impact resistance(kV)	75	75	85	/

11.Noise level: 50dB

12.Box shell protection grade: Not less than IP3X

#### Overall and mounting dimensions(mm)

YB27-12/0.4 prefabricated substation standard type Overall and mounting dimensions(mm)

	Capacity (kVA)	A	B	C	D	E	F	H
Standard type	100-250	1900	1650	1250	650/800	600	1410/1560	1450
	315	1900	1650	1350	650/800	650	1460/1610	1450
	400-500	1900	1750	1450	650/800	650	1490/1640	1550
	630	1900	1750	1550	650/800	700	1580/1730	1550
	800	1900	1850	1550	650/800	700	1640/1790	1650
	1000	1900	1850	1650	650/800	700	1640/1790	1650

YB27-12/0.4 prefabricated substation extra-strength type Overall and mounting dimensions(mm)

	Capacity (kVA)	A	B	C	D	E	F	H
Extra-Strength type	100-250	2400	1650	1250	800	600	1560	1450
	315	2400	1650	1350	800	650	1610	1450
	400-500	2400	1750	1450	800	650	1640	1550
	630	2400	1750	1550	800	700	1730	1550
	800	2400	1850	1550	800	700	1790	1650
	1000	2400	1850	1650	800	700	1790	1650



## Prefabricated Substation YB27-12/0.4 Outdoor Prefabricated Substation (US)

YB27-12/0.4 prefabricated substation comprehensiveness type Overall and mounting dimensions(mm)

	Capacity (kVA)	A	B	C	D	E	F	G	M	N
Comprehensiveness type	100-250	2400	1750	1250	800	600	1750	1450	950	550
	315	2400	1750	1350	800	650	1750	1450	950	550
	400-500	2400	1850	1450	800	650	1750	1550	950	550
	630	2400	1850	1550	800	650	1750	1550	950	550
	800	2400	1950	1550	800	650	1750	1650	950	550
	1000	2400	1950	1650	800	700	1750	1650	950	550

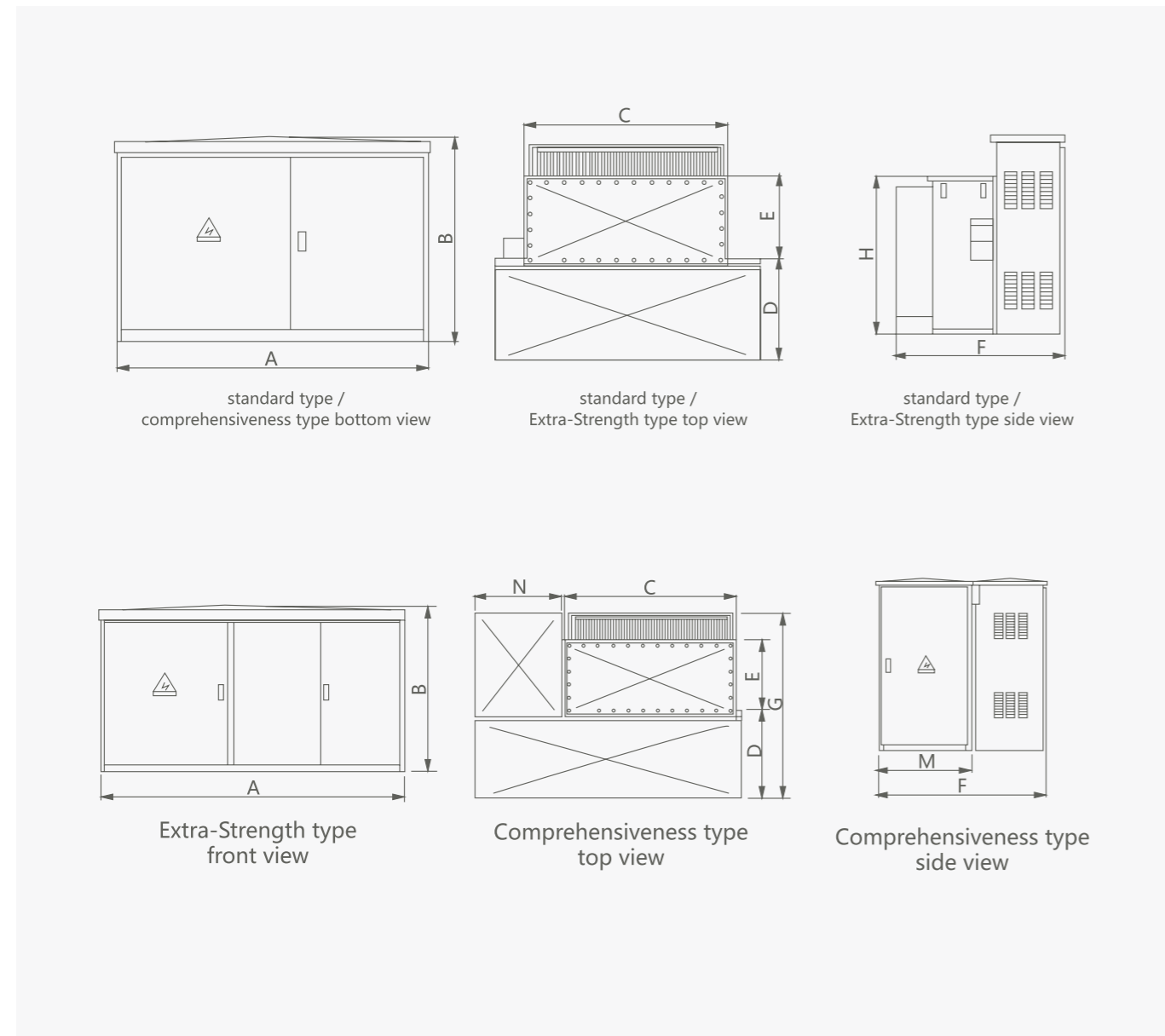

## Prefabricated Substation YB27-12/0.4 Outdoor Prefabricated Substation (US)

### Foundation drawing

Standard type and extra-strength type

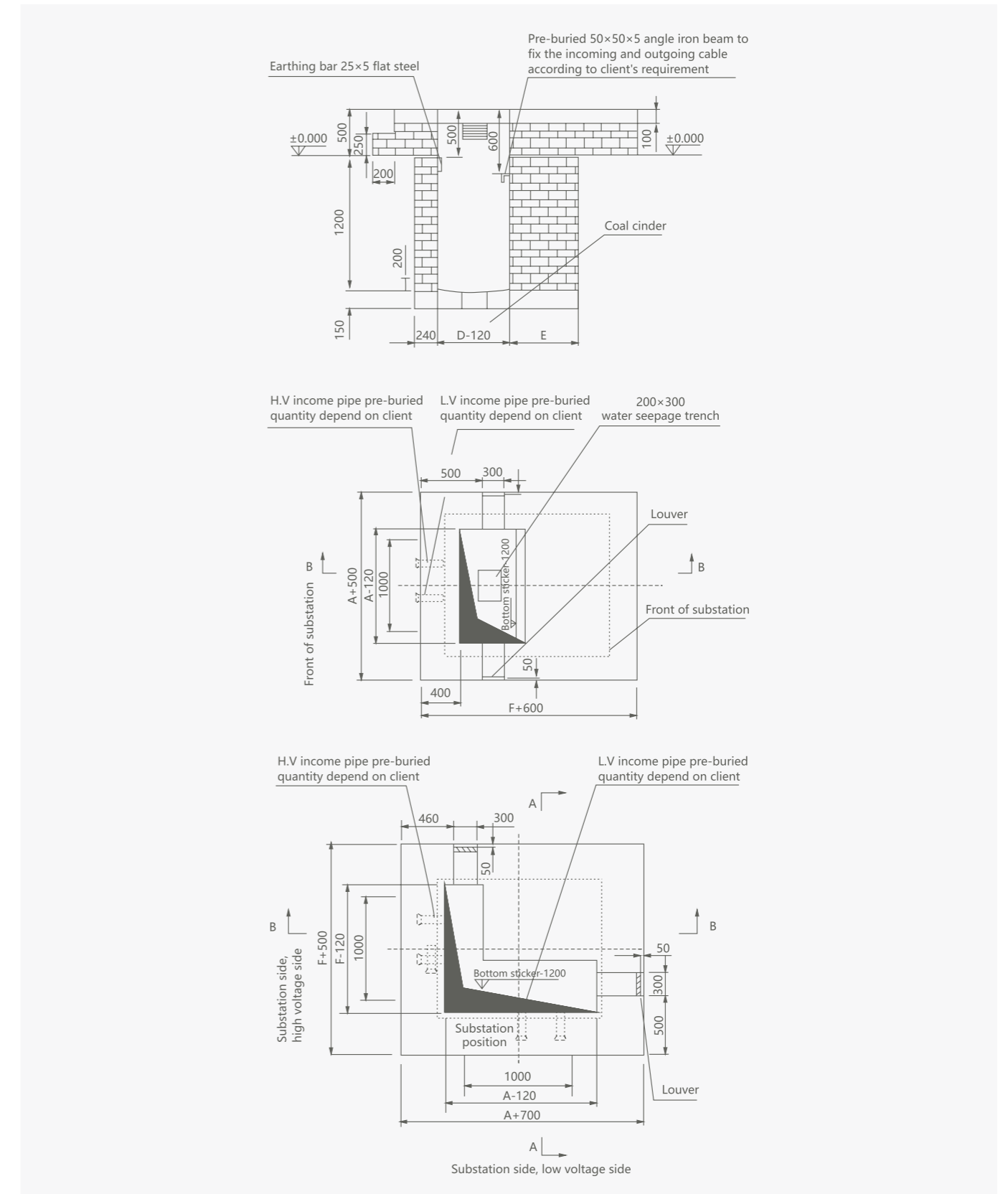

Prefabricated Substation

**YB27-12/0.4 Outdoor Prefabricated Substation (US)**

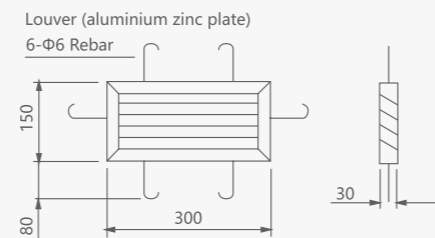
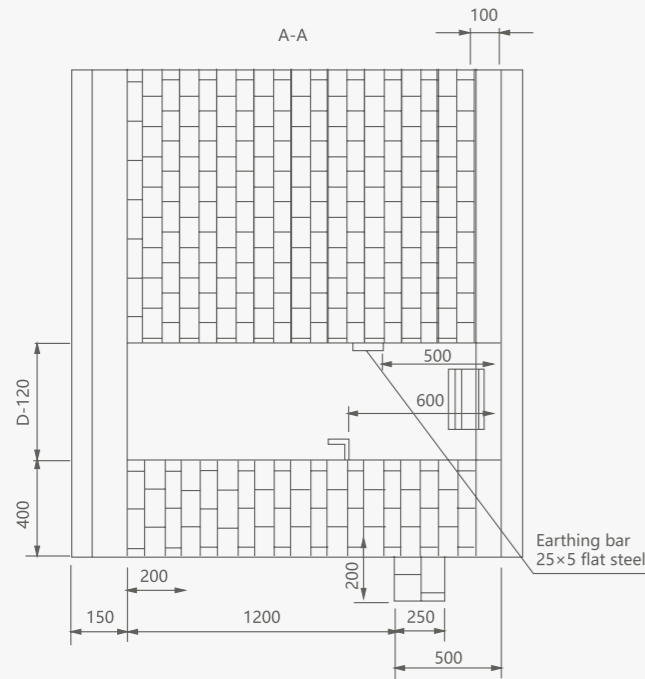
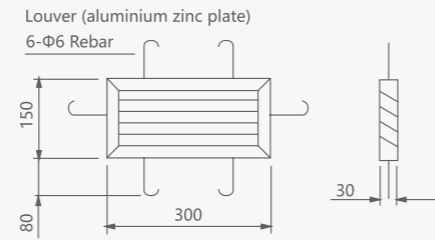
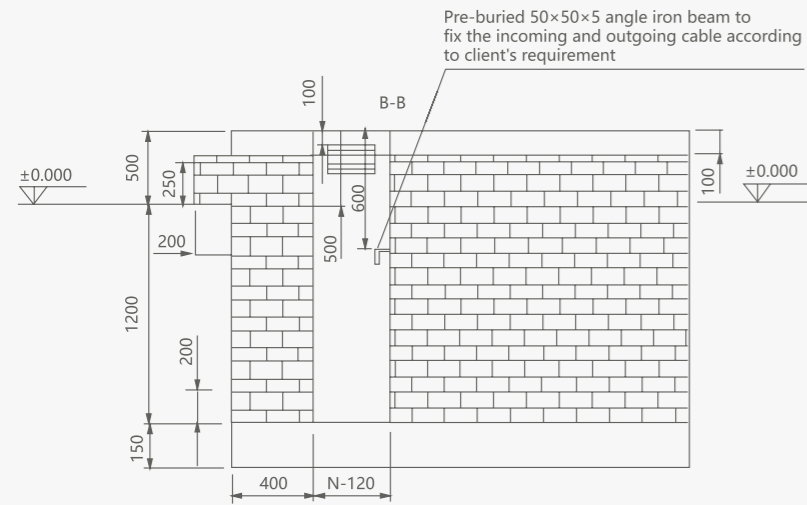

# Medium Voltage Switchgear



## Medium Voltage Switchgear **KYN61-40.5** Metalclad AC Enclosed Switchgear, Withdrawable Type

☞ KYN61-40.5 Air insulated metal clad movable switchgear is an indoor switchgear, assembly operating under the conditions of 50/60Hz three phase and rated 40.5kV AC voltage, which is applied to the transmission and distribution for generators, transformer substations and the industry and mine enterprises. It also can be used to control, protect and monitor electric circuits, and very useful for frequent operating conditions.

☞ Standard: IEC62271-200

### General



## Medium Voltage Switchgear **KYN61-40.5** Metalclad AC Enclosed Switchgear, Withdrawable Type

### Selection

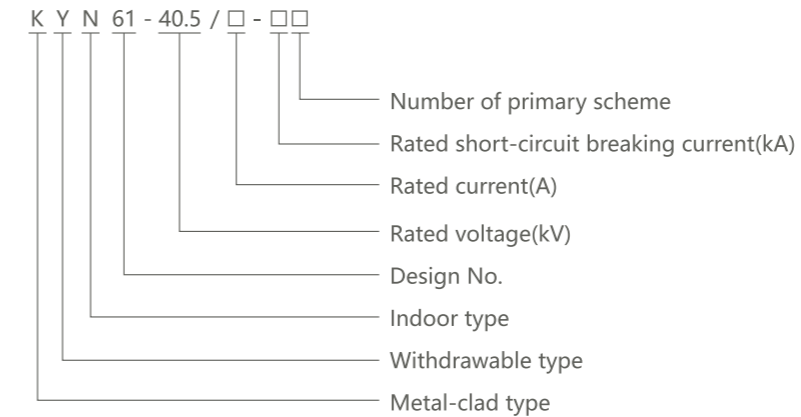

### Operating conditions

1. Ambient air temperature: -15°C~+40°C
2. Altitude: ≤1000m
3. Relative humidity : Daily average≤95%; Monthly average≤90%
4. Earthquake intensity:≤magnitude 8.
5. Applicable in the places without corrosive and flammable gas.

Note: Customized products are available.

### Features

1. The cabinet is made of aluminum-zinc coated sheet processed by CNC equipment and assembled with bolts or rivets, with a fully modular structure.
2. This switchgear has various functions to prevent misoperations, including preventing loaded trolleys from moving, preventing live coupling and earthing switches, and preventing inadvertent entry into live compartments.
3. The switchgear is equipped with a ZN85 vacuum circuit breaker with excellent performance and a handcart, and the main busbar is connected without the need for transitional transfer.
4. This switchgear is an advanced, stable performance, reasonable structure, easy-to-use, safe and reliable power distribution equipment

## Medium Voltage Switchgear KYN61-40.5 Metalclad AC Enclosed Switchgear, Withdrawable Type

### Technical data

Switchgear parameter

No.	Item	Unit	Value
1	Rated voltage	kV	40.5
2	Rated current	A	630/1250/1600/2000/2500
3	Rated frequency	Hz	50/60
4	Power frequency withstand voltage in 1 min	Phase, Earthed	kV 95
		Isolating Fracture	kV 110
5	Lightning impulse withstand voltage(Peak)	Phase, Earthed	kV 185
		Isolating Fracture	kV 215
6	Rated current of the main busbar	A	630/1250/1600/2000/2500
7	Rated current of the branch busbar	A	630/1250/1600/2000/2500
8	Rated short-circuit breaking current	kA	20/25/31.5
9	Rated short-time withstand current	kA	20/25/31.5
10	Rated peak withstand current	kA	50/63/80
11	Rated short circuit making current	kA	50/63/80
12	Frequency withstand voltage in 1min of aux control loop	V	2000
13	Internal arc duration test(0.5s)	kA	31.5
14	Degree of protection	IP	IP4X(IP2X when the front door is opened)
15	Rated voltage of aux control loop	V	AC or DC 110/220

ZN85-40.5 parameter

No.	Item	Unit	Data
1	Rated voltage	kV	40.5
2	Rated insulation level	lightning impulse withstand voltage (full wave)	kV 185
		1 min power frequency withstand voltage	kV 95
3	Rated frequency	Hz	50
4	Rated current	kA	630 630,1250 1250,1600,2000,2500
5	Rated short -circuit breaking current	kA	20 25 31.5
6	Rated short -circuit making current	kA	50 63 80
7	Rated withstands current (peak)	kA	50 63 80
8	Rated short-time withstand current	kA	20 25 31.5
9	Fixed breaking time	s	≤0.07
10	Making time	Electro-magnetic mechanism	s Electro-magnetic mechanism≤0.2
		Spring mechanism	s Spring mechanism≤0.10
11	Rated operation sequence	/	Open-0.3s-close open-180s-close open
12	Mechanical life	times	10000

## Medium Voltage Switchgear KYN61-40.5 Metalclad AC Enclosed Switchgear, Withdrawable Type

### Features

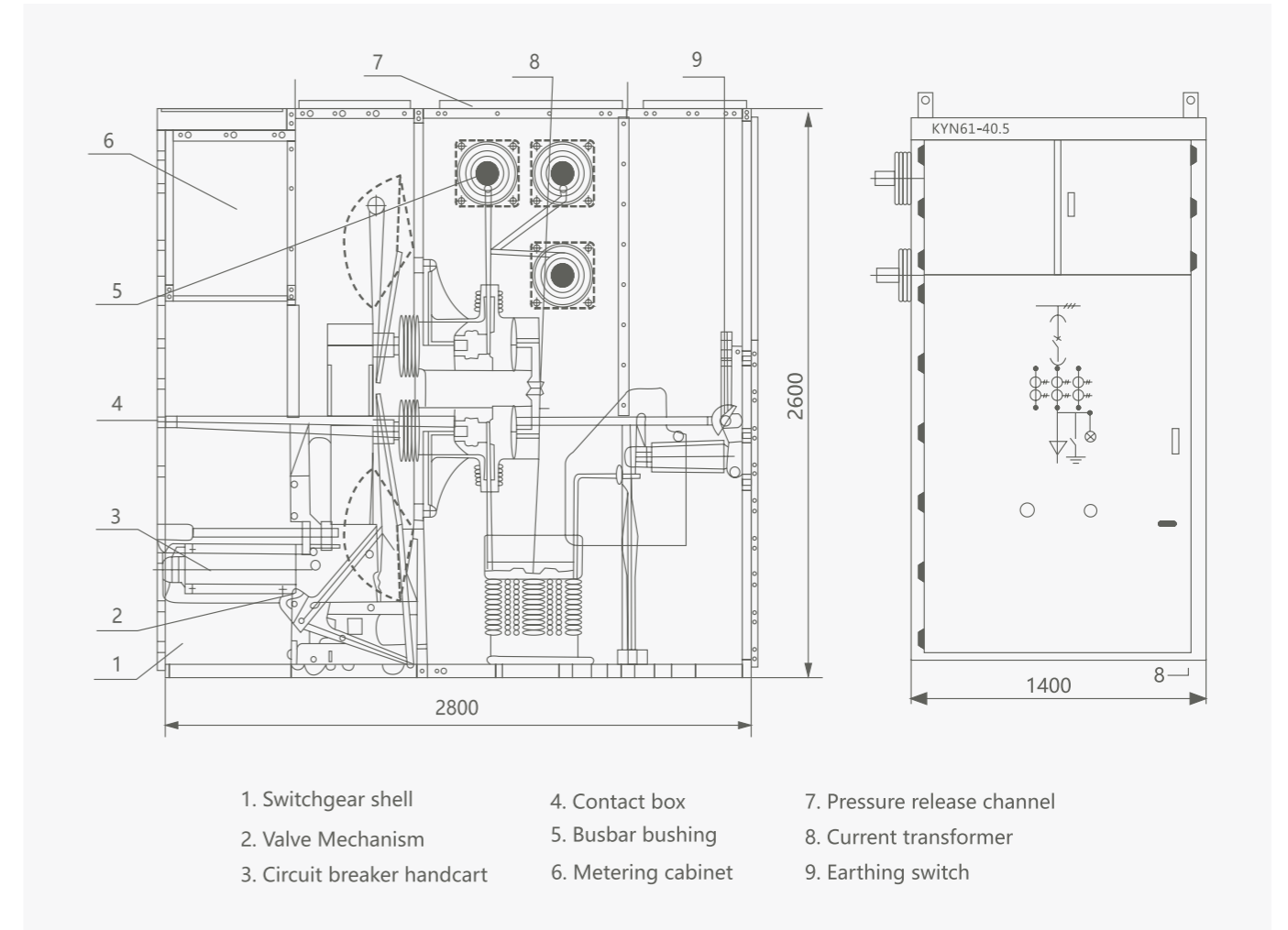

- 1. Switchgear shell
- 2. Valve Mechanism
- 3. Circuit breaker handcart
- 4. Contact box
- 5. Busbar bushing
- 6. Metering cabinet
- 7. Pressure release channel
- 8. Current transformer
- 9. Earthing switch

### Single line diagram

Program No.	01	02	03	04
Single line diagram				
Main electrical components	VCB ZN85-40.5 JNH1-40.5 CT LZB7,8,9-40.5	1 0-1 /	1 0-1 1	1 0-1 2 3
Application	Overhead incoming and outgoing feeder	Overhead incoming and outgoing feeder	Overhead incoming and outgoing feeder	Overhead incoming and outgoing feeder
Note				

**Medium Voltage Switchgear**  
**KYN61-40.5 Metalclad AC Enclosed Switchgear, Withdrawable Type**

Program No.		05	06	07	08
Single line diagram					
Main electrical components	VCB ZN85-40.5	1	1	1	1
	JNH1-40.5	0-1	0-1	0-1	0-1
	CT LZB7,8,9-40.5	/	1	2	3
Application		Cable incoming and outgoing feeder	Cable incoming and outgoing feeder	Cable incoming and outgoing feeder	Cable incoming and outgoing feeder
Note					

Program No.		09	10	11	12
Single line diagram					
Main electrical components	VCB ZN85-40.5	1	1	1	1
	CT LZB7,8,9-40.5	/	1	2	3
Application		Left(right) communicating	Left(right) communicating	Left(right) communicating	Left(right) communicating
Note					

Program No.		13	14	15	16
Single line diagram					
Main electrical components	CT LZB7, 8, 9-40.5	/	1	2	3
Application		Left(right) communicating	Left(right) communicating	Left(right) communicating	Left(right) communicating
Note					

**Medium Voltage Switchgear**  
**KYN61-40.5 Metalclad AC Enclosed Switchgear, Withdrawable Type**

Program No.		17	18	19	20
Single line diagram					
Main electrical components	VCB LZB7,8,9-40.5	/	1	2	3
	JNH1-40.5	0-1	0-1	0-1	0-1
Application		Overhead incoming and outgoing feeder	Overhead incoming and outgoing feeder	Overhead incoming and outgoing feeder	Overhead incoming and outgoing feeder
Note					

Program No.		21	22	23	24
Single line diagram					
Main electrical components	VCB LZB7,8,9-40.5	/	1	2	3
	JNH1-40.5	0-1	0-1	0-1	0-1
Application		Overhead incoming and outgoing feeder	Overhead incoming and outgoing feeder	Overhead incoming and outgoing feeder	Overhead incoming and outgoing feeder
Note					

Program No.		25	26	27
Single line diagram				
Main electrical components	CT LZX9-40.5Q	2	3	/
	Fuse XPNP-40.5	3	3	3
	Arrester HY5W-51	/	/	3
Application		Potential transformer	Potential transformer	Potential transformer
Note				

## Medium Voltage Switchgear **KYN28-24** Metalclad AC Enclosed Switchgear, Withdrawable Type

- KYN28A-24 Metalclad AC Enclosed Switchgear, Withdrawable Type (hereinafter referred to as switchgear), suitable for indoor three-phase 50/60Hz, rated voltage 24kV power system, mainly used in power plants, substations, industrial and mining enterprises and high-rise buildings. It is used to receive and distribute electric energy and to control, protect and monitor circuits.
- Standard: IEC62271-200

### General



## Medium Voltage Switchgear **KYN28-24** Metalclad AC Enclosed Switchgear, Withdrawable Type

### Selection

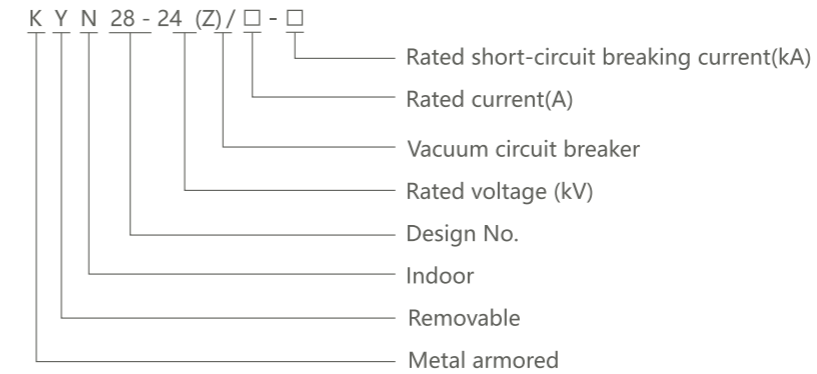

### Operating conditions

1. +15°C~+40°C. And the average value measured within 24 hours shall not exceed 35°C
2. The average monthly relative humidity shall not exceed 90%  
The average monthly water vapor pressure shall not exceed 1.8kPa;
3. Altitude: ≤1000m.
4. There is no obvious dust or smoke in the surrounding air; pollution caused by corrosive or combustible gases, vapors, or salt mist;
5. Vibration or ground motion from outside the switchgear and control equipment can be ignored;
6. The amplitude of electromagnetic interference induced in the secondary system shall not exceed 1.6kV

### Features

1. The cabinet is made of aluminum-zinc coated sheet processed by CNC equipment and assembled with bolts or rivets, with a fully modular structure.
2. This switchgear has various functions to prevent misoperations, including preventing loaded trolleys from moving, preventing live coupling and earthing switches, and preventing inadvertent entry into live compartments.  
The switchgear is equipped with high-quality VS1 series center-mounted AC high-voltage vacuum circuit breaker and fixed-sealed vacuum circuit breaker.  
The busbar adopts heat-shrinkable insulation material as the insulation means, optimized electrode shape, and compact cabinet structure.  
This switchgear is an advanced, stable performance, reasonable structure, easy-to-use, safe and reliable power distribution equipment.

## Medium Voltage Switchgear KYN28-24 Metalclad AC Enclosed Switchgear, Withdrawable Type

### Technical data

Item		Unit	Data			
Rated voltage		kV	24			
Rated frequency of circuit breaker		Hz	50/60			
Rated insulation level	Lightning impulse withstand voltage (peak)	kV	Phase-to-phase, phase-to-ground	60	Isolating fracture	79
	1min power frequency withstandvoltage (effective value)	kV	Phase-to-phase, phase-to-ground	125	Isolating fracture	145
	Auxiliary control circuit power frequency withstand voltage	V	2000			
Rated current of circuit breaker		A	630, 1250, 1600 2000, 2500, 3150			
Rated short-circuit breaking current		kA	20	31.5		
Rated short-circuit closing current (peak)		kA	50	80		
Rated short-time withstand current		kA	20	31.5		
Rated peak withstand current		kA	50	80		
Auxiliary control circuit rated voltage		V	AC or DC 110/220			
Protection degree		/	IP4X(IP2X when the front door is opened)			
Overall and mounting dimensions(mm) s(width*depth*height)		mm	800×1810×2380	1000×1810×2380		
Weight		kg	840~1140			

Note:The depth of the overhead incoming and outgoing cabinet is 2360mm

### VS1-24 Technical data

Item		Unit	Data	
Rated voltage		kV	24	
Rated insulation level	Lightning impulse withstand voltage (peak)	kV	60	
	1min power frequency withstandvoltage (effective value)	kV	125	
Rated frequency of circuit breaker		Hz	50/60	
Rated current of circuit breaker		A	630, 1250, 1600, 2000	630, 1250, 1600, 2000, 2500, 3150
Rated short-circuit breaking current		kA	20	31.5
Rated short-circuit closing current (peak)		kA	50	80
Rated short-time withstand current		kA	20	31.5
Rated peak withstand current		kA	50	80
Rated single capacitor bank breaking current		A	630	
Rated back to back capacitor bank breaking current		A	400	
Rated short-circuit breaking current breaking times		Times	50	
Mechanical life		Times	20000	
Rated operating sequence			O-0.3s-CO-180s-CO	

## Medium Voltage Switchgear KYN28-24 Metalclad AC Enclosed Switchgear, Withdrawable Type

### VS1-24 Technical data

Item		Unit	Data
Rated voltage	closing and tripping coil	V	AC220, AC110, DC220, DC110
	opening and tripping coil		
Working current	closing and tripping coil	A	AC220 or DC220 : 1.1A
	opening and tripping coil		AC110 or DC110 : 3.1A
Energy storage motor power		W	80, 100
Energy storage motor rated voltage		V	AC220, AC110, DC220, DC110
Energy storage time		S	≤10

### Structure and working principle

The KYN28A-24 switchgear consists of two main parts: a cabinet body and a removable component (commonly known as a handcart). The cabinet is divided into multiple functional compartments using metal partitions, such as busbar compartment, circuit breaker compartment, cable compartment, and relay instrument compartment. The movable components of the switchgear can be equipped with vacuum circuit breaker handcart, voltage transformer handcart, lightning arrester handcart, isolation handcart, and fuse handcart.

A. busbar room    B. Circuit breaker handcart room    C. Cable room    D. Relay instrument room

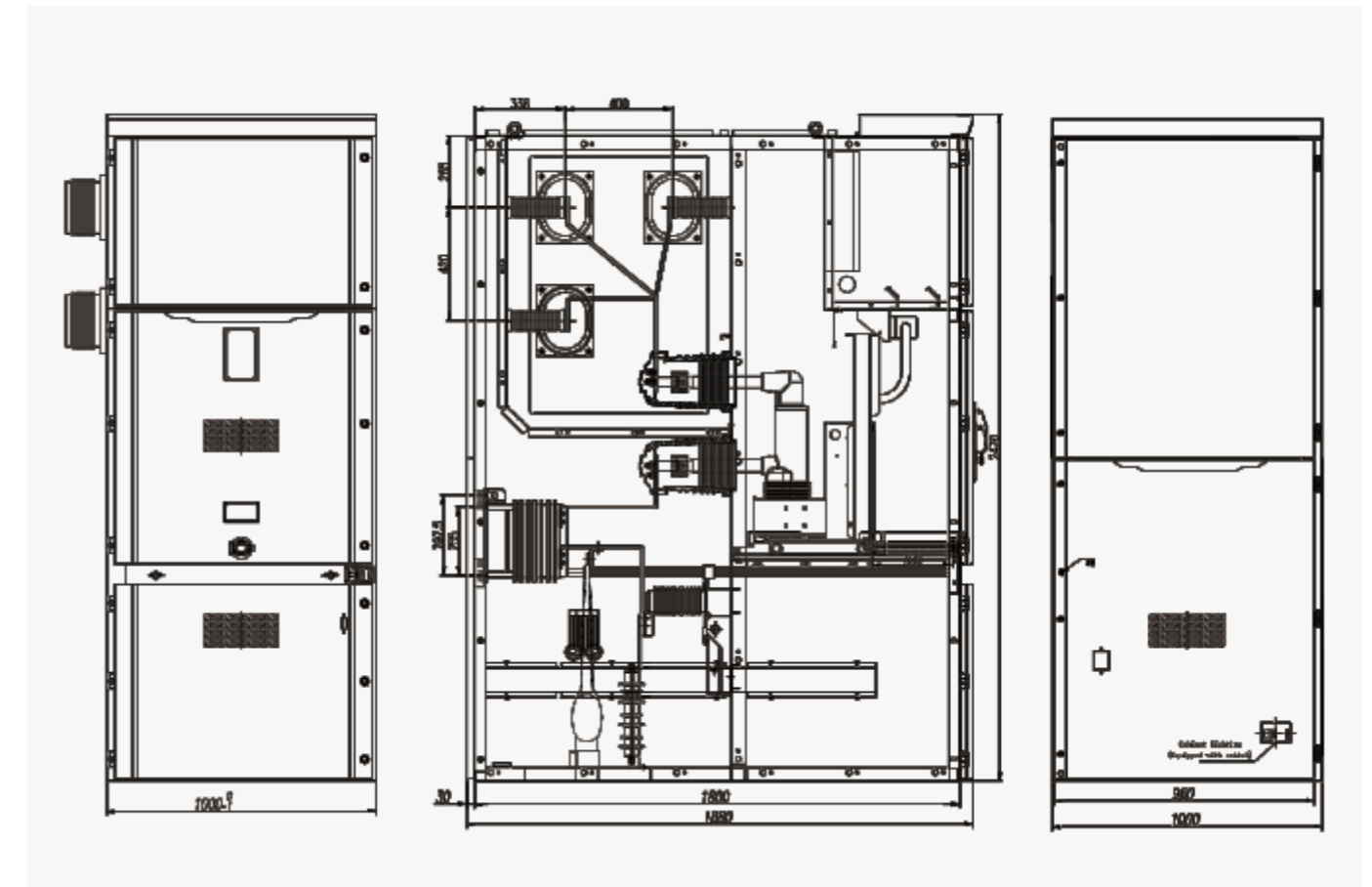

Figure 1 Schematic diagram of KYN28A-24 Switchgear

## Medium Voltage Switchgear **KYN28-12** Metalclad AC Enclosed Switchgear, Withdrawable Type

☞ KYN28A-12 indoor metal clad movable switchgear is a complete power distribution device for 3.6kV~12KV, 3 phase AC 50/60Hz , single bus sectionalized system. It is mainly used for power transmission of middle/smallgenerators in power plants, power receiving, transmission for substations in power distribution and power system of factories, mines and enterprises etc. so as to control, protect and monitor the system.

☞ Standard: IEC62271-200

### General



## Medium Voltage Switchgear **KYN28-12** Metalclad AC Enclosed Switchgear, Withdrawable Type

### Selection

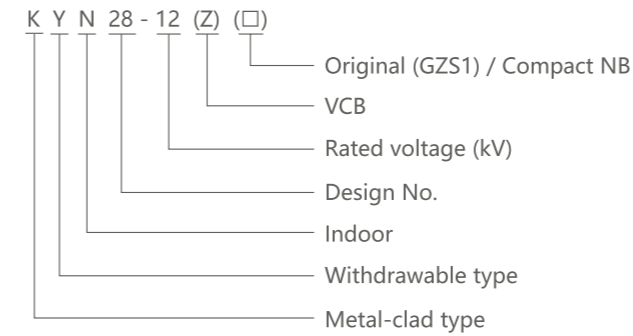

### Operating conditions

1. Ambient air temperature: -15°C~+40°C.
2. Altitude: ≤1000m.
3. Relative humidity : Daily average≤95%, daily averange of vapour pressure≤2.2kpa.
4. Earthquake intensity: ≤magnitude 8.
5. Applicable in the places without corrosive and flammable gas and water vapor.
6. Used in place without frequently intense vibrant.

Note: Customized products are available.

### Features

1. The cabinet is made of aluminum-zinc coated sheet processed by CNC equipment, and is assembled by bolts or rivets. The structure is fully assembled.
2. The switchgear has various functions to prevent misoperation, including preventing the load-bearing handcart from moving, preventing the live closing and grounding
3. The switchgear is equipped with high-performance VS1 series medium-voltage AC vacuum circuit breakers and solid-sealed vacuum circuit breakers.
4. The busbar adopts heat-shrinkable insulation materials and optimized electrode shapes, with a compact cabinet structure. This switchgear is technologically advanced, with stable performance, reasonable structure, convenient use, and safe and reliable power distribution equipment



## Medium Voltage Switchgear KYN28-12 Metalclad AC Enclosed Switchgear, Withdrawable Type

### Technical data

No.	Item		Unit	Data	
1	Rated voltage		kV	3.6, 7.2, 12	
2	Rated frequency of circuit breaker		Hz	50	
3	Rated current of circuit breaker		A	630, 1250, 1600, 2000, 2500, 3150, 4000	
4	Rated current of switchgear		A	630, 1250, 1600, 2000, 2500, 3150, 4000	
5	Rated short-time withstand current (4s)		kA	16, 20, 25, 31.5, 40, 50	
6	Rated withstands current (peak)		kA	40, 50, 63, 80, 100, 25	
7	Rated short-circuit breaking current		kA	16, 20, 25, 31.5, 40, 50	
8	Rated short-circuit closing current (peak)		kA	40, 50, 63, 80, 100, 25	
9	Rated insulation level	1 min power frequency withstands voltage	between poles, pole to earth	kV	24, 32, 42
			between open contacts	kV	24, 32, 48
		Lightening impulse withstands voltage (peak)	between poles, pole to earth	kV	40, 60, 75
			between open contacts	kV	46, 70, 85
10	Protection level			Shell: IP4X; IP2X when the CPT and CB doors are open	

Note:

- The short circuit capacity of the current transformer should be separately considered.
- See technical parameters of ZN63A-12 in related catalogues of our company.

### VS1-12 Technical data

Item	Unit	Value			
Contact distance	mm	12			
Contact travel		75			
Average closing speed (6mm~contact closed)	m/s	42			
Average opening speed (contact separation -6mm)		20	25	31.5	40
Opening time (rated voltage)	m/s	630	630, 1250, 1600,	1250, 1600, 2000,	
Closing time (rated voltage)		1250	2000, 2500, 3150	2500, 3150, 4000	
Contact closing bounce time	m/s	20	25	31.5	40
Three phase opening asynchrony		63		80	100
Allowable cumulative thickness of wear for moving and stationary contacts	mm	50	63	80	100
Rated short-circuit breaking current breaking times	Times	80	50	30	
Secondary circuit power frequency withstand current	V	2000			
Rated operating sequence		Opening -0.3s - closing and opening -180s - closing and opening -180s - closing and opening -180s - closing and opening (40kA)			
Rated thermal stability time	S	4			
Rated single/back to back capacitor bank breaking current	A	630/400		800/400	
Mechanical life	Times	20000		10000	

## Medium Voltage Switchgear KYN28-12 Metalclad AC Enclosed Switchgear, Withdrawable Type

### Structure

- A. Busbar compartment
- B. Circuit breaker trolley compartment
- C. Cable compartment
- D. Realy ,instrument compartment
- 1. Shell
- 2. Small branch bus
- 3. Bus bushing
- 4. Main bus
- 5. Static contact assembly
- 6. Contact box
- 7. Current transformer
- 8. Earthing switch
- 9. Cable
- 10. Surge arrester
- 11. Earthing main busbar

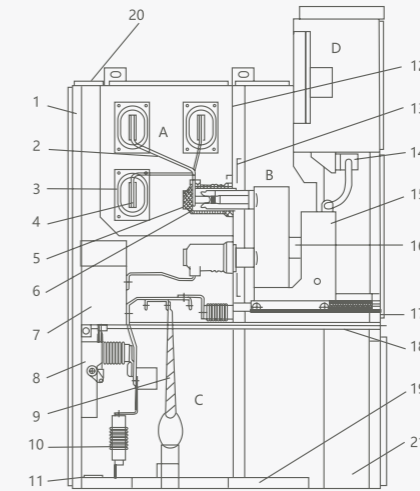

- 12. Detachable partition
- 13. Board (Valve)
- 14. Secondary plug
- 15. Circuit breaker handcart
- 16. Heating device
- 17. Withdrawable level board
- 18. Earthing switch operation
- 19. Base board
- 20. Pressure releasing channel
- 21. Control mini bus

### Overall and mounting dimensions (refer to picture 2, sheet 2)

(mm) Sheet 2

Shape	Description	Size (mm)
Width (W)	Rated current of branch bus $\leq 1250A$ , heat stable current $\leq 40KA$	800(650)
	Rated current of branch bus $\geq 1600A$	1000
Depth (C)	Cable Incoming and outgoing feeder	1500
	Overhead incoming and outgoing feeder	1660
Height (B)		2300(2200)

Outline size

Picture 2

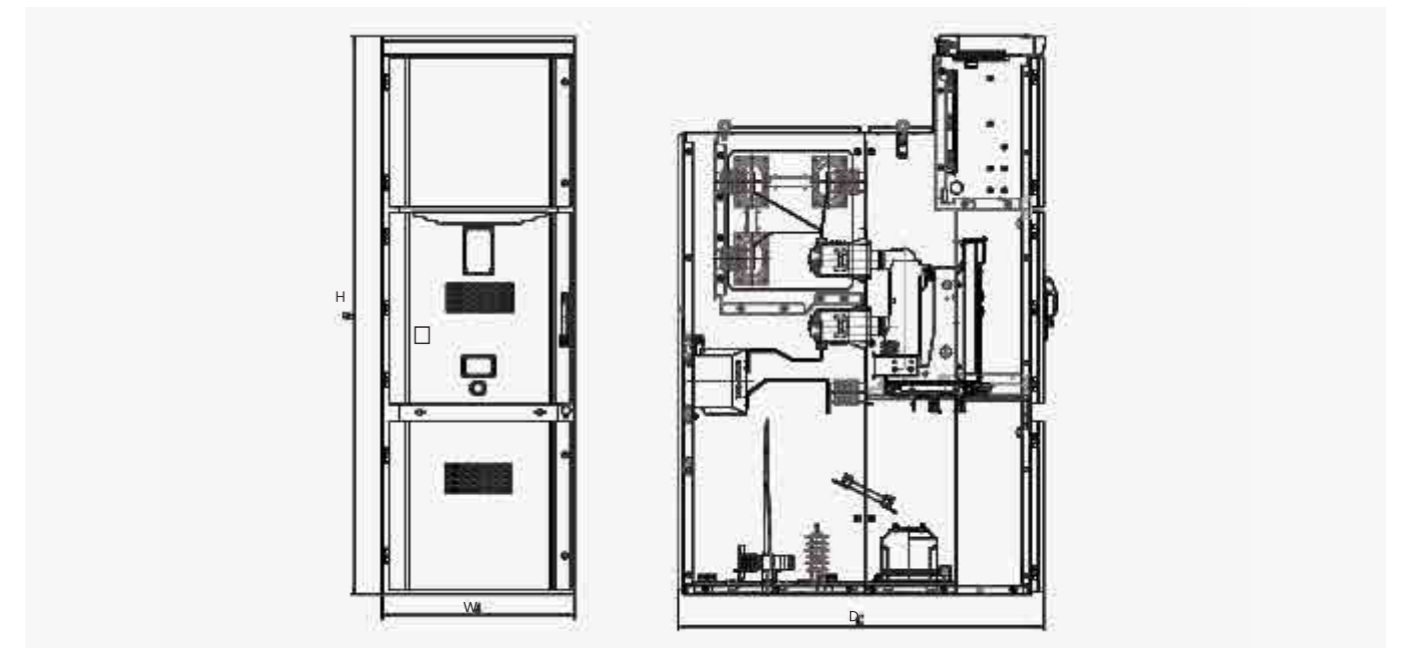

# Medium Voltage Switchgear

## KYN28-12 Metalclad AC Enclosed Switchgear, Withdrawable Type

### Single line diagram

Sheet 4

Program No.	01	02	03	04	05	06	
Single line diagram							
Overall and mounting dimensions (mm) (Width×Depth×Height)	800×1500×2300 1000×1500×2300	800×1500×2300 1000×1500×2300	800×1500×2300 1000×1500×2300	800×1500×2300 1000×1500×2300	800×1500×2300 1000×1500×2300	800×1500×2300 1000×1500×2300	
Main electrical components	Rated current(A)	630~3150					
	VCB(ZN63 or VD4)	1	1	1	1	1	1
	CT LZJB9 series	2	2	2	3	3	3
	Earthing switch JN15	/	1	1	/	1	1
	Surge arrester HY5W	/	/	3	/	/	3
Circuit name	Receiving, feeding	Receiving, feeding	Receiving, feeding	Receiving, feeding	Receiving, feeding	Receiving, feeding	
Note	Cabinet weight will be 1000mm when rated current is above 1600A.						

Program No.	07	08	09	10	11	12	
Single line diagram							
Overall and mounting dimensions (mm) (Width×Depth×Height)	800×1500×2300 1000×1500×2300	800×1500×2300 1000×1500×2300	800×1500×2300 1000×1500×2300	800×1500×2300 1000×1500×2300	800×1500×2300 1000×1500×2300	800×1500×2300 1000×1500×2300	
Main electrical components	Rated current(A)	630~3150					
	VCB(ZN63 or VD4)	1	1	1	1	1	1
	CT LZJB9 series	2	2	2	2	3	3
	Earthing switch JN15	/	1	/	1	/	1
	Circuit name	Communication (Right)	Communication (Right)	Communication (Right)	Communication (Right)	Communication (Right)	Communication (Right)
Note	Cabinet weight will be 1000mm when rated current is above 1600A.						

# Medium Voltage Switchgear

## KYN28-12 Metalclad AC Enclosed Switchgear, Withdrawable Type

Continued Sheet 4

Program No.	13	14	15	16	17	18	
Single line diagram							
Overall and mounting dimensions (mm) (Width×Depth×Height)	800×1500×2300 1000×1500×2300	800×1500×2300 1000×1500×2300	800×1500×2300 1000×1500×2300	800×1500×2300 1000×1500×2300	800×1500×2300 1000×1500×2300	800×1500×2300 1000×1500×2300	
Main electrical components	Rated current(A)	630~3150					
	VCB(ZN63 or VD4)	1	1	1	1	1	1
	CT LZJB9 series	3	3	2	2	2	2
	Earthing switch JN15	/	1	/	1	/	1
	Circuit name	Communication (Left)	Communication (Left)	Overhead incoming (left communication)	Overhead incoming (left communication)	Overhead incoming (right communication)	Overhead incoming (right communication)
Note	Cabinet weight will be 1000mm when rated current is above 1600A.						

Program No.	19	20	21	22	23	24	
Single line diagram							
Overall and mounting dimensions (mm) (Width×Depth×Height)	800×1500×2300 1000×1500×2300	800×1500×2300 1000×1500×2300	800×1500×2300 1000×1500×2300	800×1500×2300 1000×1500×2300	800×1500×2300 1000×1500×2300	800×1500×2300 1000×1500×2300	
Main electrical components	Rated current(A)	630~3150					
	VCB(ZN63 or VD4)	1	1	1	1	1	1
	CT LZJB9 series	3	3	2	2	2	2
	Earthing switch JN15	/	1	/	1	/	1
	Circuit name	Overhead incoming (left communication)	Overhead incoming (left communication)	Overhead incoming (right communication)	Overhead incoming (right communication)	Overhead incoming and outgoing feeder	Overhead incoming and outgoing feeder
Note	Cabinet weight will be 1000mm when rated current is above 1600A.						

# Medium Voltage Switchgear KYN28-12 Metalclad AC Enclosed Switchgear, Withdrawable Type

Continued Sheet 4

Program No.	25	26	27	28	29	30	
Single line diagram							
Overall and mounting dimensions (mm) (Width×Depth×Height)	800×1660×2300 1000×1660×2300	800×1660×2300 1000×1660×2300	800×1660×2300 1000×1660×2300	800×1660×2300 1000×1660×2300	800×1660×2300 1000×1660×2300	800×1660×2300 1000×1660×2300	
Main electrical components	Rated current(A) 630~3150						
	VCB(ZN63 or VD4)	1	1	1	1	1	
	CT LZJB9 series	2	3	3	3	2	2
	Potential transformer	/	/	/	/	JDZ10-10   2	JDZ10-10   2
	H.V fuse RN2-10	/	/	/	/	3	3
	Earthing switch JN15	1	/	1	1	/	1
	Surge arrester HY5W	3	/	/	3	/	/
	Circuit name	Overhead incoming and outgoing feeder	Overhead incoming and outgoing feeder	Overhead incoming and outgoing feeder	Overhead incoming and outgoing feeder	Cable incoming+PT	Cable incoming+PT
Note	Cabinet weight will be 1000mm when rated current is above 1600A.						

Program No.	31	32	33	34	35	36	
Single line diagram							
Overall and mounting dimensions (mm) (Width×Depth×Height)	800×1500×2300 1000×1500×2300	800×1500×2300 1000×1500×2300	800×1500×2300 1000×1500×2300	800×1500×2300 1000×1500×2300	800×1500×2300 1000×1500×2300	800×1500×2300 1000×1500×2300	
Main electrical components	Rated current(A) 630~3150						
	VCB(ZN63 or VD4)	1	1	1	1	1	
	CT LZJB9 series	2	3	3	3	2	2
	Potential transformer	JDZ10-10   2	JDZ10-10   2	JDZ10-10   2	JDZ10-10   2	JDZ10-10   3	JDZ10-10   3
	H.V fuse RN2-10	3	3	3	3	3	3
	Earthing switch JN15	/	/	1	/	/	/
	Surge arrester HY5W	3	/	/	3	/	/
	Circuit name	Cable incoming+PT	Cable incoming+PT	Cable incoming+PT	Cable incoming+PT	Cable incoming+PT	Cable incoming+PT
Note	Cabinet weight will be 1000mm when rated current is above 1600A.						

# Medium Voltage Switchgear KYN28-12 Metalclad AC Enclosed Switchgear, Withdrawable Type

Continued Sheet 4

Program No.	37	38	39	40	41	42	
Single line diagram							
Overall and mounting dimensions (mm) (Width×Depth×Height)	800×1500×2300 1000×1500×2300	800×1500×2300 1000×1500×2300	800×1500×2300 1000×1500×2300	800×1500×2300 1000×1500×2300	800×1500×2300 1000×1500×2300	800×1500×2300 1000×1500×2300	
Main electrical components	Rated current(A) 630~3150						
	VCB(ZN63 or VD4)	1	/	/	/	/	
	CT LZJB9 series	2	/	/	/	/	
	Potential transformer	JDZ10-10   3	JDZ10-10   2	JDZ10-10   3	JDZ10-10   2	JDZ10-10   3	JDZ10-10   2
	H.V fuse RN2-10	3	3	3	3	3	3
	Surge arrester HY5W	3	/	/	3	3	3
	Circuit name	Cable incoming+PT	Voltage measure	Voltage measure	Voltage measure +Surge arrester	Voltage measure +Surge arrester	Voltage measure +Surge arrester
	Note	Cabinet weight will be 1000mm when rated current is above 1600A.					

Program No.	43	44	45	46	47	48	
Single line diagram							
Overall and mounting dimensions (mm) (Width×Depth×Height)	800×1500×2300 1000×1500×2300	800×1500×2300 1000×1500×2300	800×1500×2300 1000×1500×2300	800×1500×2300 1000×1500×2300	800×1500×2300 1000×1500×2300	800×1500×2300 1000×1500×2300	
Main electrical components	Rated current(A) 630~3150						
	Potential transformer	JDZ10-10   3	JDZ10-10   2	JDZ10-10   2	JDZ10-10   3	JDZ10-10   3	JDZ10-10   2
	H.V fuse RN2-10	3	3	3	3	3	3
	Surge arrester HY5W	3	/	/	/	/	/
	Circuit name	Voltage measure +Surge arrester	Voltage measure +Bus couple	Voltage measure +Bus couple	Voltage measure +Bus couple	Voltage measure +Bus couple	Voltage measure+Surge arrester+Bus couple
	Note	Cabinet weight will be 1000mm when rated current is above 1600A.					

## Medium Voltage Switchgear KYN28-12 Metalclad AC Enclosed Switchgear, Withdrawable Type

Continued Sheet 4

Program No.	49	50	51	52	53	54
Single line diagram						
Overall and mounting dimensions (mm) (Width×Depth×Height)	800×1500×2300 1000×1500×2300	800×1500×2300 1000×1500×2300	800×1500×2300 1000×1500×2300	800×1500×2300 1000×1500×2300	800×1500×2300 1000×1500×2300	800×1500×2300 1000×1500×2300
Main electrical components	Rated current(A) 630~3150					
	Potential transformer JDZ10-10 2		JDZ10-10 3		JDZ10-10 3	
	H.V fuse RN2-10 3		3		3	
	Surge arrester HY5W 3		3		3	
Circuit name	Voltage measure+Surge arrester+Bus couple	Voltage measure+Surge arrester+Bus couple	Voltage measure+Surge arrester+Bus couple	Bus couple	Bus couple	Disconnection
Note	Cabinet weight will be 1000mm when rated current is above 1600A.					

Program No.	55	56	57	58	59	60
Single line diagram						
Overall and mounting dimensions (mm) (Width×Depth×Height)	800×1500×2300 1000×1500×2300	800×1500×2300 1000×1500×2300	800×1500×2300 1000×1500×2300	800×1500×2300 1000×1500×2300	800×1500×2300 1000×1500×2300	800×1500×2300 1000×1500×2300
Main electrical components	Rated current(A) 630~3150					
	Potential transformer /		/		JDZ10-10 2	
	H.V fuse RN2-10 /		/		3	
	Earthing switch Jn15 /		/		/	
Circuit name	Disconnection+ Communication(Left)	Disconnection+ Communication(Right)	Disconnection+ Communication(Left)+Voltage measure	Disconnection+ Communication(Right)+Voltage measure	Outlet and phase exchange	Outlet and phase exchange
Note	Cabinet weight will be 1000mm when rated current is above 1600A.					

## Medium Voltage Switchgear KYN28-12 Metalclad AC Enclosed Switchgear, Withdrawable Type

Continued Sheet 4

Program No.	61	62	63	64	65	66
Single line diagram						
Overall and mounting dimensions (mm) (Width×Depth×Height)	800×1500×2300 1000×1500×2300	800×1500×2300 1000×1500×2300	800×1500×2300 1000×1500×2300	800×1500×2300 1000×1500×2300	800×1500×2300 1000×1500×2300	800×1500×2300 1000×1500×2300
Main electrical components	Rated current(A) 630~3150					
	CT LZBJ9 series 2		2		3	
	Potential transformer JDZ10-10 2		JDZ10-10 2		JDZ10-10 2	
	H.V fuse RN2-10 /		/		/	
Circuit name	Measurement+ left communication	Measurement+ Right communication	Measurement+ left communication	Measurement+ Right communication	Measurement+ left communication	Measurement+ Right communication
Note	Cabinet weight will be 1000mm when rated current is above 1600A.					

Program No.	67	68	69	70	71	72
Single line diagram						
Overall and mounting dimensions (mm) (Width×Depth×Height)	800×1500×2300 1000×1500×2300	800×1500×2300 1000×1500×2300	800×1500×2300 1000×1500×2300	800×1500×2300 1000×1500×2300	800×1500×2300 1000×1500×2300	800×1500×2300 1000×1500×2300
Main electrical components	Rated current(A) 630~3150					
	VCB(ZN63 or VD4) /		/		1	
	CT LZBJ9 series 3		3		2	
	Potential transformer JDZX10-10 3		JDZX10-10 2		JDZX10-10 2	
Circuit name	Measurement+ left communication	Measurement+ Right communication	Incoming+ Measurement	Incoming+ Measurement	Incoming+ Measurement	Incoming+ Measurement
Note	Cabinet weight will be 1000mm when rated current is above 1600A.					

## Medium Voltage Switchgear **XGN15-12~24** Air-insulated RMU(Fixed Type)

- Rating:  
Rated voltage 12/24KV, rated current reach to 630A.  
Application:  
mainly applicable in urban power grid features and renovation project, industrial and mining enterprises, high-rise buildings and communal facilities .For power distribution, controlling and protection on electric equipment as the loop power supply unit or terminal equipment. It also can be installed in pre-loaded substation
- Feature:  
Use SF6 load switch and load switch-fuse combination as main switch. Equipped with vacuum load switch and spring operating mechanism which can be operated by hand or electric. Grounding switch and insulating switch are equipped with hand operating mechanism, with small volume and high security.
- Standard: IEC60420

### General



## Medium Voltage Switchgear **XGN15-12~24** Air-insulated RMU(Fixed Type)

### Selection

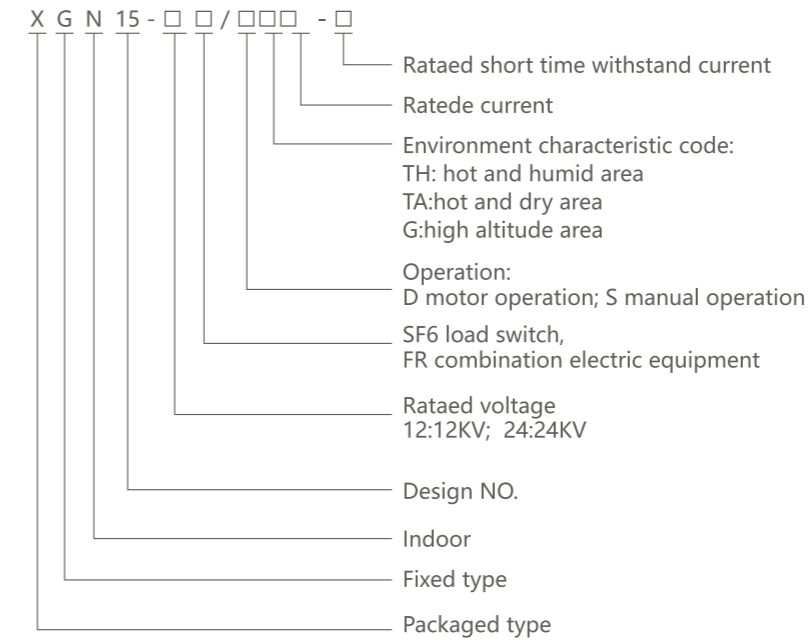

### Operating conditions

1. Ambient air temperature: -15°C~+40°C. Daily average temperature: ≤35°C.
  2. Altitude: ≤1000m.
  3. Relative humidity : Daily average ≤95% ,daily average of vapour pressure ≤2.2kpa Monthly average ≤90%, monthly average of vapour pressure ≤1.8kpa.
  4. Earthquake intensity: ≤magnitude 8.
  5. Applicable in the places without corrosive and flammable gas.
- Note: Customized products are available.

### Features

1. Modular design, where each unit module can be combined and expanded arbitrarily, facilitating flexible system configurations and wide adaptability.
2. The cabinet adopts armored structure with metal partitions between compartments.
3. The operating mechanism adopts corrosion-resistant metals, and the rotating parts are designed with self-lubricating bearings, ensuring unaffected performance in various environments and eliminating the need for regular maintenance.
4. To accommodate power grid automation and improve distribution reliability, it can be equipped with motorized mechanisms, distribution network control terminal units, and possesses telecontrol functions.
5. The compact design of the cabinet incorporates a three-position rotary load switch, effectively reducing the number of components and enabling mechanical interlocking for five protection measures.
6. The primary circuit simulation single-line diagram and analog display can demonstrate the internal status of the switch, enabling easy, accurate, and safe operation.

## Medium Voltage Switchgear XGN15-12~24 Air-insulated RMU(Fixed Type)

### Technical data

Rated voltage		Unit	12KV			24KV
Item	/	Load switch cabinet	Combined electrical cabinet	Circuit breaker cabinet	20KV SF6 Ring switch equipment	
Rated frequency	HZ	50/60	50/60	50/60	50/60	
Rated current	A	/				
Main busbar	A	630	630	630	630	
Branch busbar	A	630	125 <sup>①</sup>	630	630/□100 <sup>②</sup>	
Rated insulation level	KV	/				
Power frequency withstand voltage	Phase-to-phase and phase-to-ground	KV	42	42	42	65
	Gap between breaks	KV	48	48	48	/
	Break control and auxiliary circuit	KV	2	2	2	/
Lightning impulse withstand voltage	Phase-to-phase and phase-to-ground	KV	75	75	75	85
	Gap between breaks	KV	85	85	85	/
Rated short-time withstand current	KA	/				
Main circuit	KA	20/3s	-	25/2s	/	
Grounding circuit	KA	20/25	-	25/2s	/	
Rated peak withstand current	KA	50	-	63	/	
Rated short-circuit making current	KA	50	80	63	50	
Rated short-circuit breaking current	KA	-	31.5	25	31.5	
Rated transfer current	A	-	1750	-	870	
Rated active load breaking current	A	630	-	-	630	
Rated closed loop breaking current	A	630	-	630	/	
Rated cable charging breaking cable	A	10	-	15	25	
Protection degree	/	IP3X	IP3X	IP3X	/	
Mechanical life	Load switch	times	5000	5000	10000	3000
	Grounding switch	times	2000	2000	2000	2000

Notes : ① up to the fuse rated current

② ≤100(Load switch - Fuse combination cabinet)

## Medium Voltage Switchgear XGN15-12~24 Air-insulated RMU(Fixed Type)

### Structure

#### ● Busbar room

1. The busbar room is arranged at the upper part of the cabinet.  
In the busbar room, the main busbar is connected together and runs through
2. the entire row of switchgear

#### ● Load switch

1. There is a three position load switch installed in the switch room. The shell of the load switch is made of epoxy resin cast columns, and filled with sulfur hexafluoride (SF6) gas as the insulation medium. SF6 gas density meters or gas density meters with alarm contacts can be installed in the switch room according to customer requirements

#### ● Cable room

1. The load switch has a spacious cable room, mainly used for cable connections
2. with sufficient space also to install lightning arresters, current transformers, lower grounding switches and other components  
Operating mechanism, interlock mechanism and low voltage control room
3. The low-voltage room with interlocking functions as a control panel also
4. Spring operating mechanism and mechanical interlocking device with position indicator installed in low-voltage room
5. The low-voltage room can also be equipped with auxiliary contacts, trip coils, emergency trip mechanisms, capacitive live displays, keylocks, and electric
6. operating devices
7. The low-voltage room space can also be used to install control circuits, metering instruments and protective relay
8. The 750mm wide cabinet has two identical low-voltage chambers, which can hold more accessories.

The whole XGN15 switchgear can be divided into upper and lower parts. The upper part of the cabinet includes busbar room, load switch, operating mechanism and low-voltage room, which is separated from the lower part of the cable room. Therefore, it is safer and easier to repair and modify the equipment installed in the upper unit, and to replace the whole upper unit.

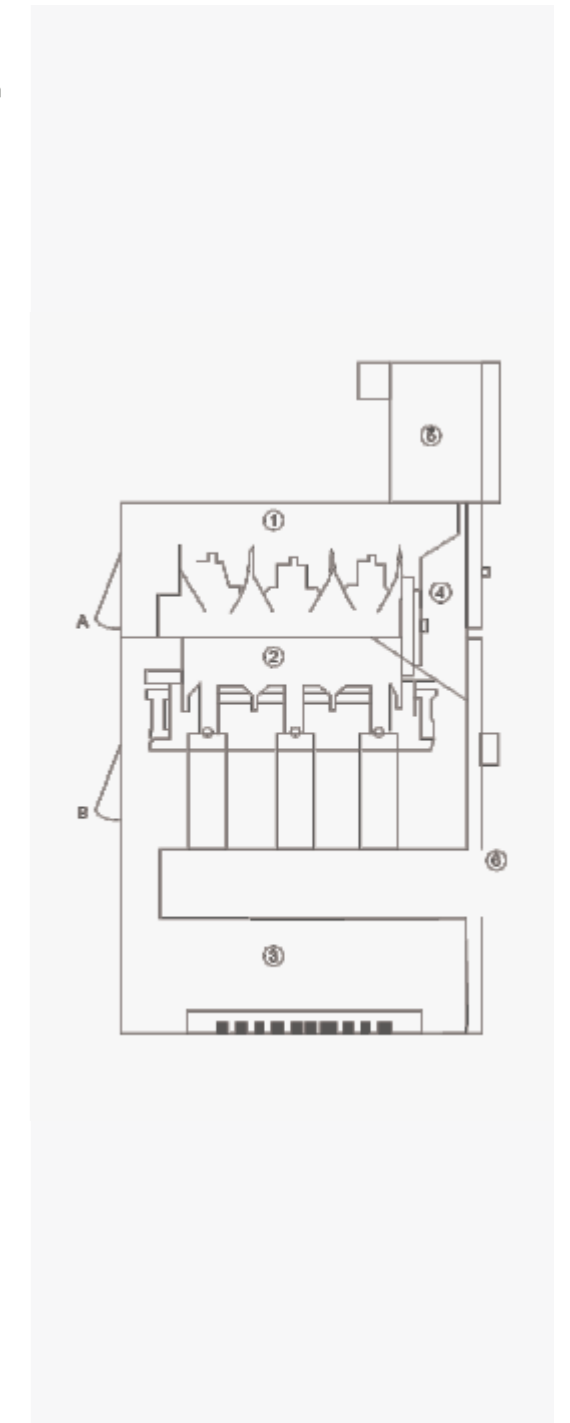

Medium Voltage Switchgear  
**XGN15-12~24 Air-insulated RMU(Fixed Type)**

Phase plan

Phase plan number	DC01	DC08	DC01	DC07	DC04
main bus-bar TMY					
XGN15-12/24 Disposable system diagram					
Configuration	Incoming cabinet	Outgoing cabinet	Outgoing cabinet	Configuration	Measuring cabinet
Load switch FLN□-□D	1	1	1	1	1
Load switch FLRN□-□D	/	1	/	/	2
Charged display DXN-T/Q	1	/	1	1	3
Current Transformer LZZBJ9-□	/	/	/	/	2
Voltage transformer JDZ-□	/	3	/	/	/
Lightning arrester HY5WS	3	/	3	3	2
Fuse XRNT-□/□A	/	3	/	/	/
Meter	/	/	/	/	/
Protection method	/	/	/	/	/
Auxiliary functions	/	/	/	/	/
Operation mode	Manual operation	Manual operation	Manual operation	Manual operation	/

Medium Voltage Switchgear  
**XGN15-12~24 Air-insulated RMU(Fixed Type)**

XGN15-24 Overall and mounting dimensions(mm)

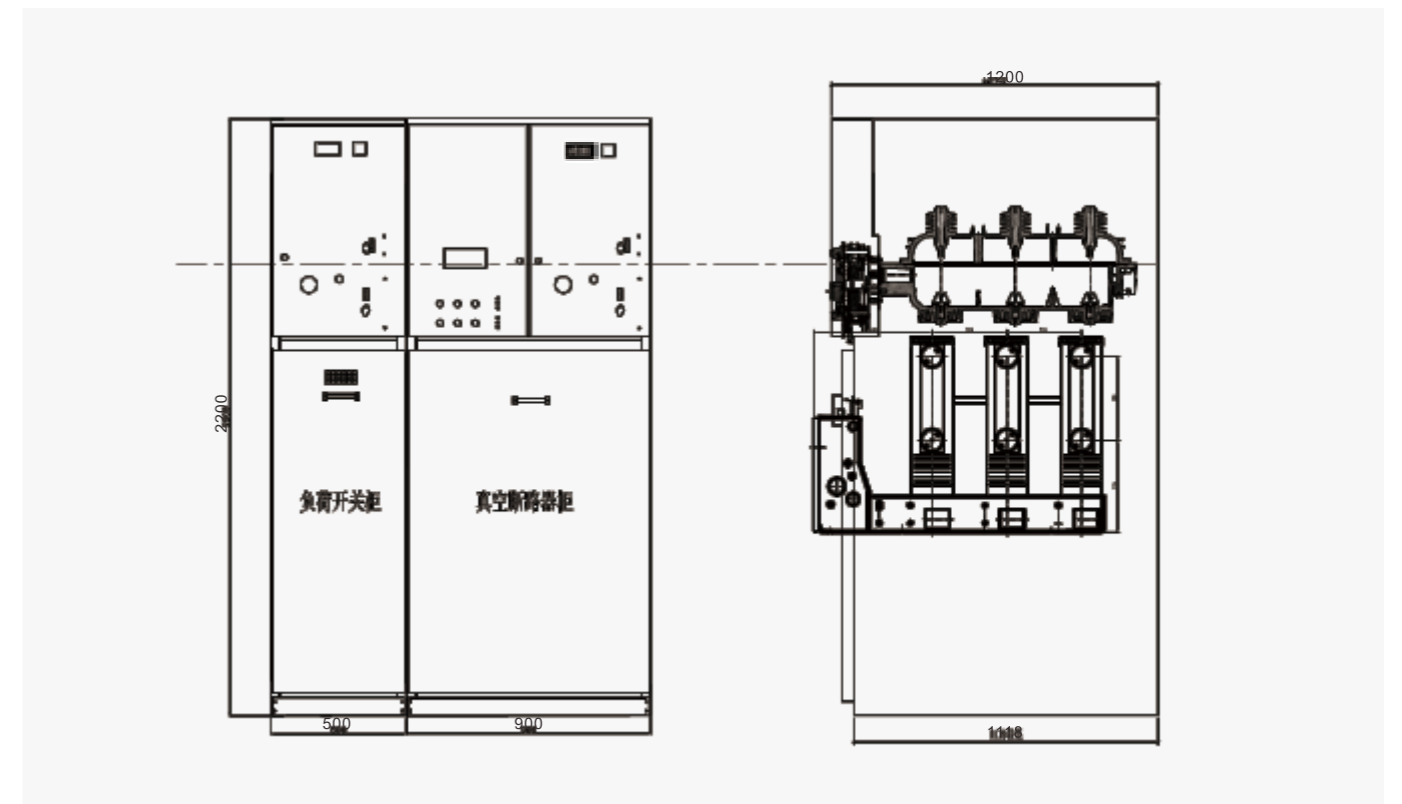

# Medium Voltage Switchgear XGN15-12~24 Air-insulated RMU(Fixed Type)

POWER TRANSMISSION AND  
DISTRIBUTION PRODUCT SELECTION

PROFESSIONAL MANUFACTURER OF  
HIGH AND LOW VOLTAGE PRODUCTS



## XGN15-12 Overall and mounting dimensions(mm)

## Schematic diagram of foundation

Picture 1 Switchgear diagrammatic sketch Picture 2

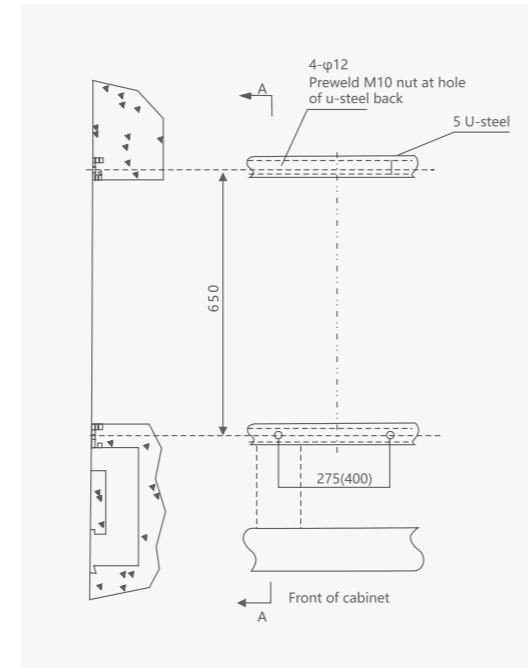
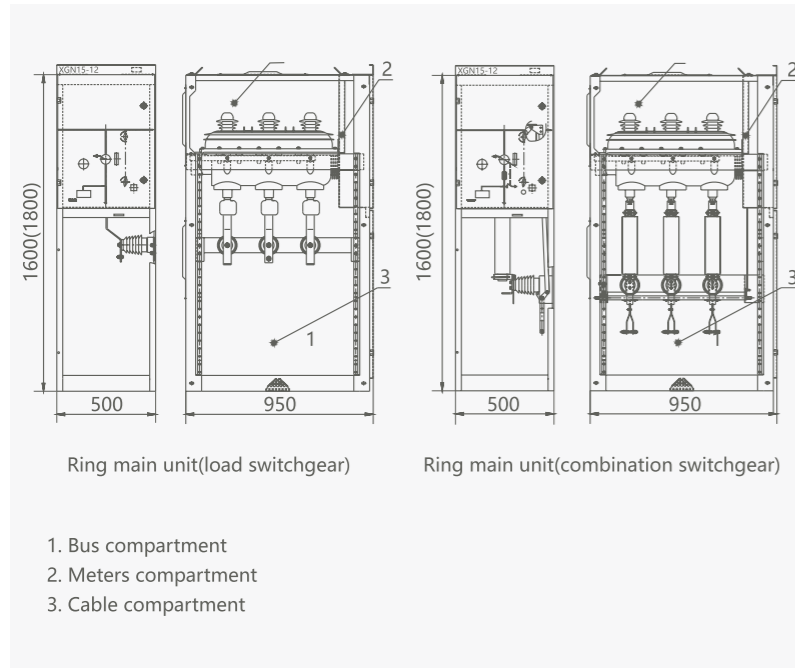

Switchgear installation Overall and mounting dimensions(mm)

Cable incoming and outgoing configuration

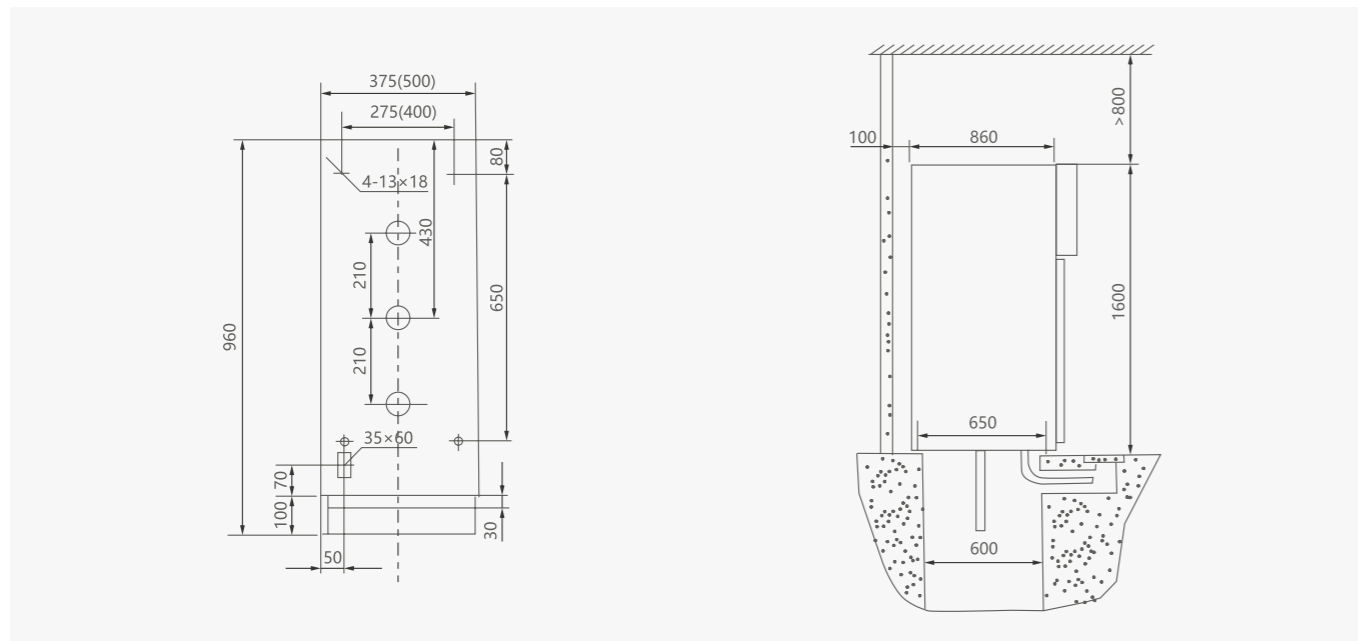

## Ordering information

1. Main circuit diagram, busbar diagram for main circuit, allocation diagram.
2. Switchgear outline size.
3. spare parts and their quantity.
4. Customized products are available per your requirements.

# Medium Voltage Switchgear YSM6-12~24 Air-insulated RMU(Fixed Type)

- YSM6-12/24 unit type SF6 RMU with SF6 load switch as main switch, for whole cabinet is suitable for electric distribution automation and compact also expandable metal close switchgear. It characters in its simple structure, flexible operation, reliable interlocking and convenient installation etc., which can provide the satisfactory technical projects both for different application occasions and users. With the adoption of sensor technology and the protection relay up to date, plus the advanced technology and flexible assembly project.
- YSM6-12/24 unit type SF6 RMU can completely meet the requirement of continuously variable market. It can take self-produced SF6-12/24 load break switch; Operational methods for the main switch inside ring main unit can be either manual or electric power driven. And it can meet the requirement of "Four Controls" when matched with FTU and RTU.

**General**





## Medium Voltage Switchgear YSM6-12~24 Air-insulated RMU(Fixed Type)

### Selection

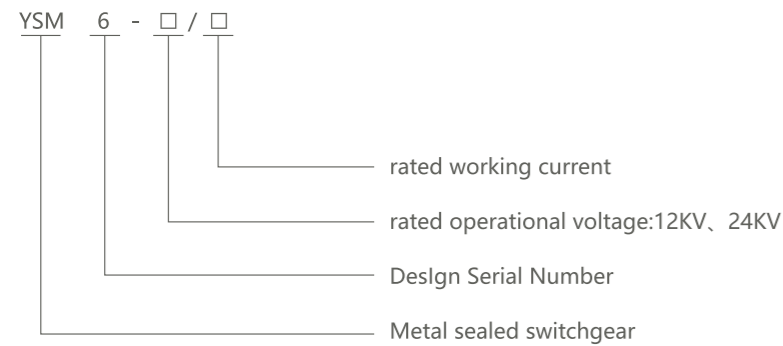

### Operating conditions

1. Air temperature: Maximum temperature: +40°C; Minimum temperature:-5°C
2. Humidity: Monthly average humidity 95%; Daily average humidity 90% .
3. Altitude above sea level: Maximum installation altitude: 2000m
4. Ambient air not apparently polluted by corrosive and flammable gas, vapor etc.
5. No frequent violent shake

### Features

1. Incoming unit with switch disconnecter(Load break switch) schemas With other extra components optional Outgoing unit with
2. Fuse-switch protection schemas
3. With other extra components optional Incoming/outgoing circuit breaker protection schemas With other extra components
4. optional MV metering schemas
5. With other extra components optional Casings (Bus bar Panel) schemasWith other extra components optional
6. Others

## Medium Voltage Switchgear YSM6-12~24 Air-insulated RMU(Fixed Type)

### Technical data

NO.	Items	Unit	Parameter	
1	Rated voltage	kV	12	24
2	Rated frequency	Hz	50/60	
3	Rated current	A	630/800	
4	1min Power frequency withstand voltage	kV	48	60
5	Lightning impulse withstand voltage	kV	75	125/150
6	Rated short circuit breaking current (peak)	kA	80	63
7	Rated active load/close circuit breaking current	A	63	50
8	Rated transferring current	A	1700	1200
9	Rated short circuit making current (peak)	kA	80	63
10	Rated cable(line) charging breaking current	A	50 and 10	
11	Cable charge breaking current in earthing fault	A	20	20
12	Rated withstand current (peak)	kA	80	63
13	Short time withstand current (2s)	kA	31.5	25
14	Mechanism life	times	2000	

Note: For short circuit breaking and peak current is based on Fuse plus combination.

### For distribution switchboard schema

1. Switch disconnecter

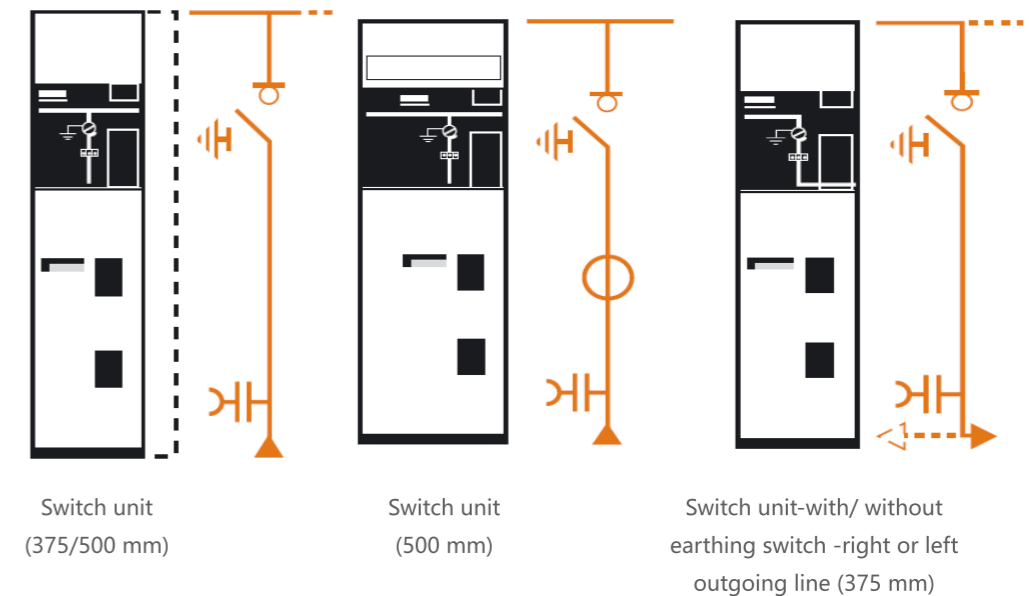

Note: Extra components for example lightning arresters or lower earthing switch is optional.

**Medium Voltage Switchgear**  
**YSM6-12~24 Air-insulated RMU(Fixed Type)**

2. Fuse-switch protection

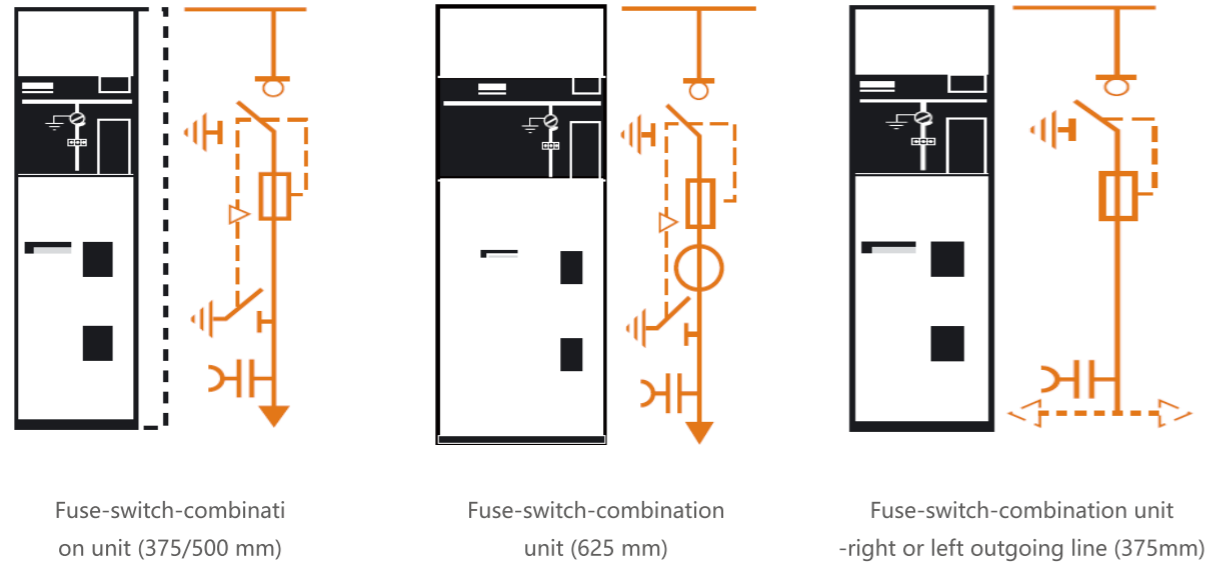

Note: Extra components for example lightning arresters or zero sequence CT is optional.

3. Circuit-breaker protection

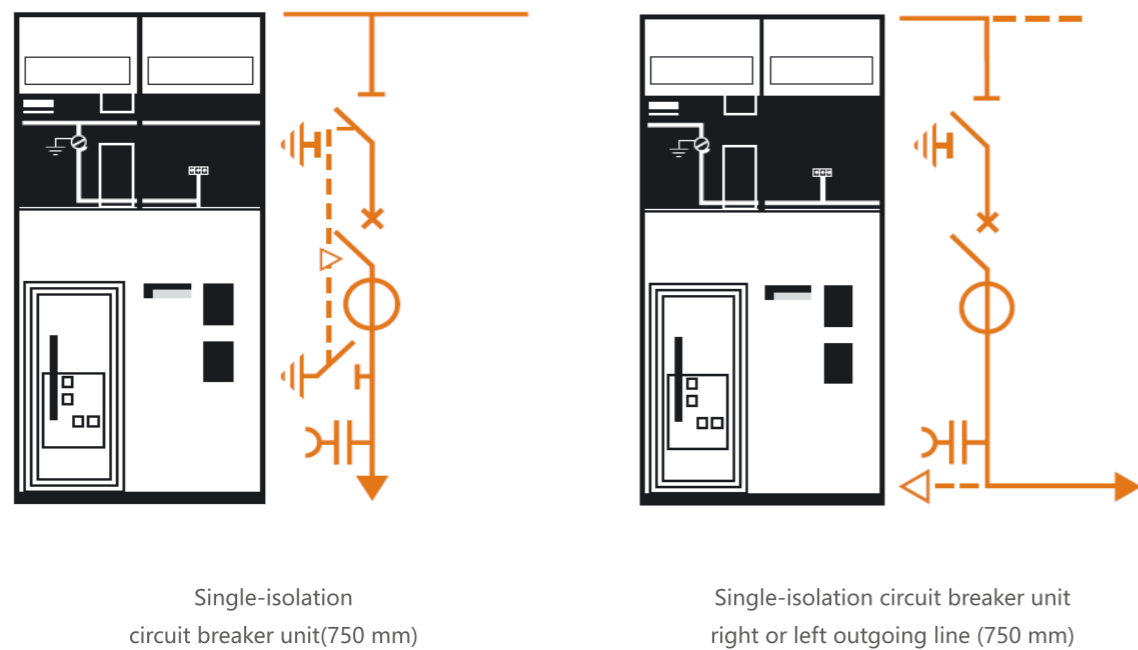

Note: 1. For HV SF6 circuit breaker also with many types can be selected. It is according to client's requirement . ( SF1/Schneider, PF/Areva, etc.) Also Vacuum circuit breaker is also optional.(VD4/S-12/24 or SF6-12/24)

2. Other extra components for example Zero sequence CT is considering after communicated by our company.

**Medium Voltage Switchgear**  
**YSM6-12~24 Air-insulated RMU(Fixed Type)**

4. MV metering

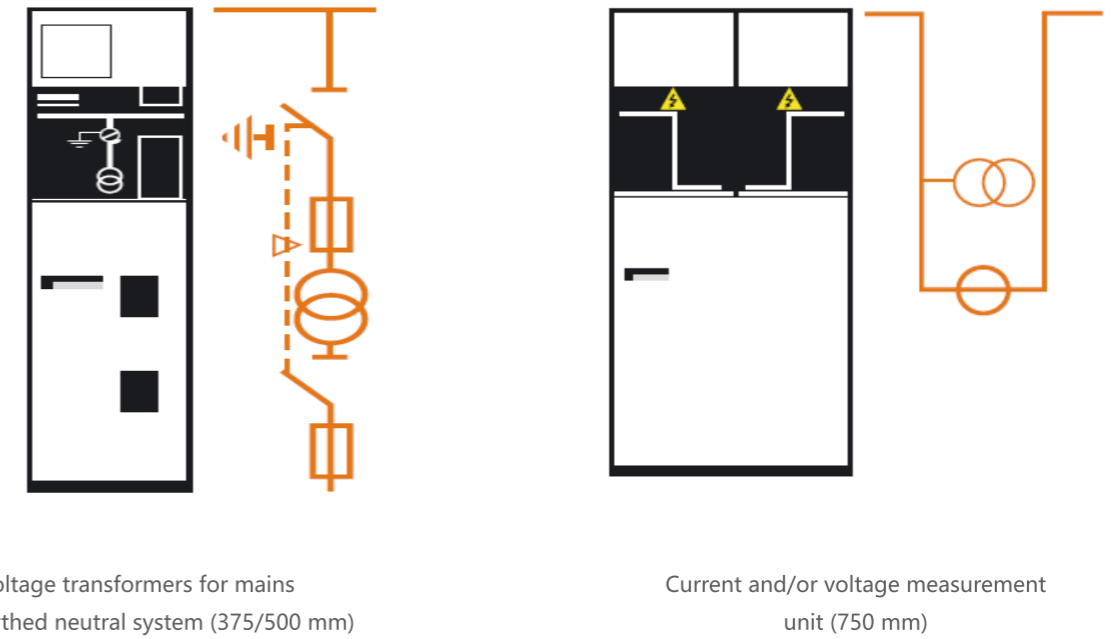

Note: Extra components for example lightning arresters or zero sequence CT is optional.

5. Casings (Bus bar Panel)

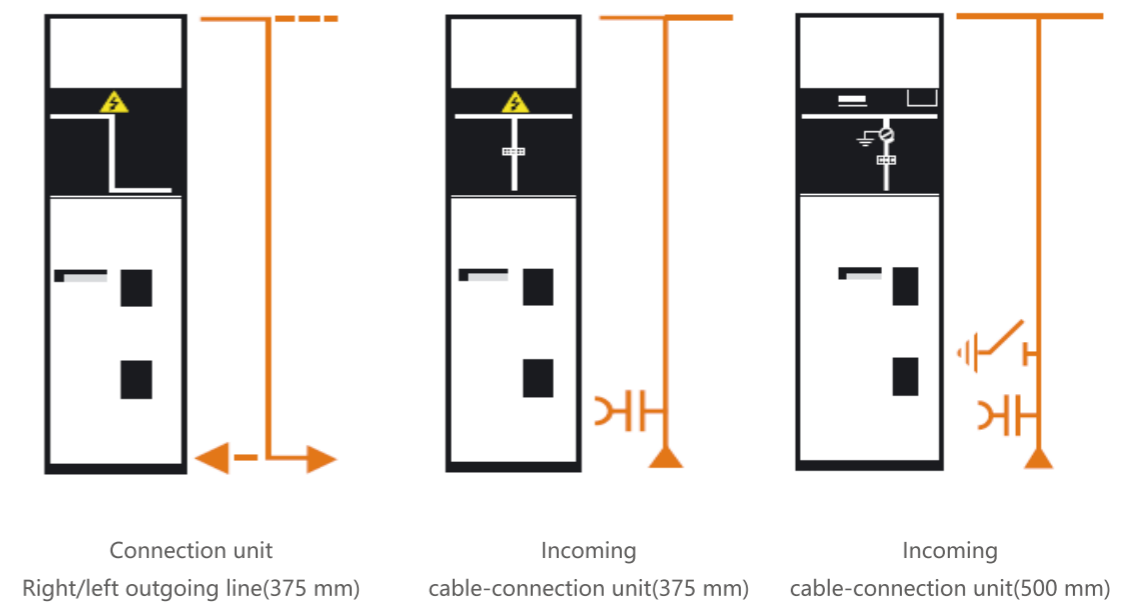

Note: Other extra components is optional (Disconnecting switch panel, Voltage transformer panel, etc.)

## Medium Voltage Switchgear YSM6-12~24 Air-insulated RMU(Fixed Type)

### 2. Fuse-switch protection

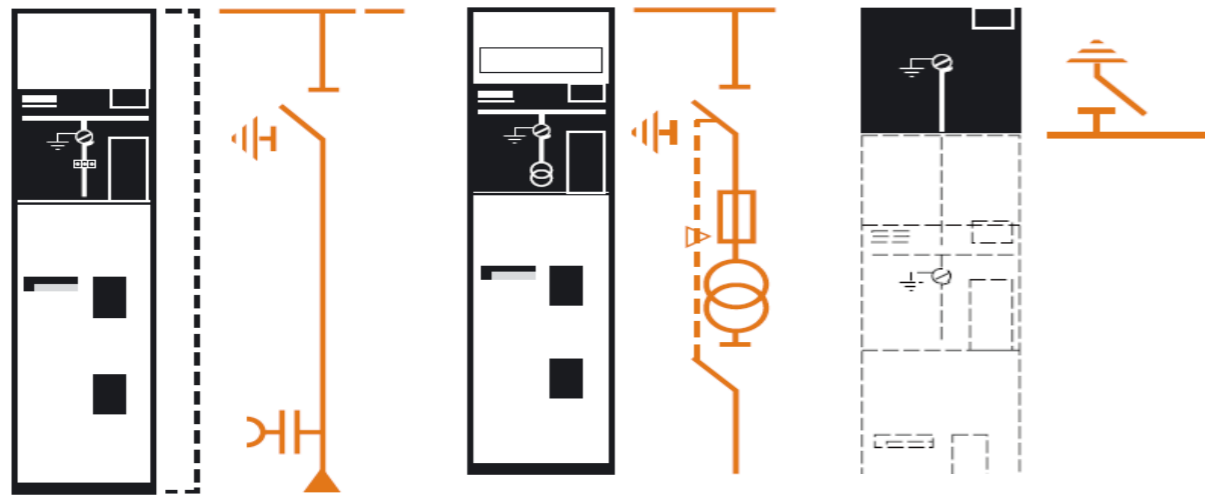

Disconnector unit  
(375/500 mm)

MV/LV transformer unit  
for auxiliaries(375 mm)

Busbar earthing  
compartment(375 mm)

### 5 parts for the unit type SF6 ring main unit:

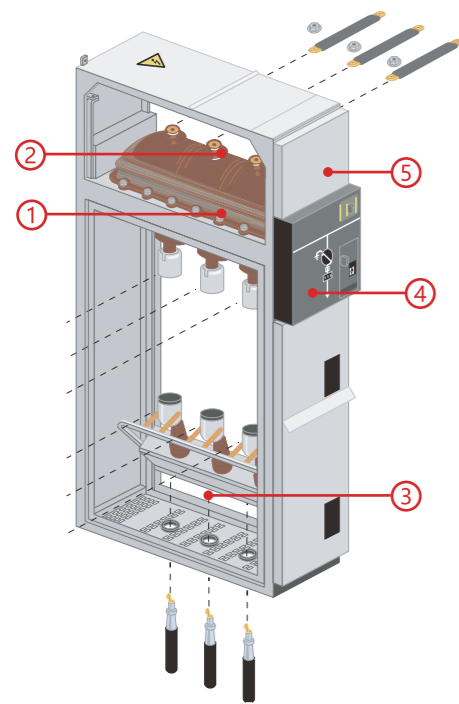

1. switch cubicle switch-disconnector and earthing switch in an enclosure filled with SF6 and satisfying "sealed pressure system" requirements.
  2. bus-bar cubicle all in the same horizontal plane, thus enabling later switchboard extensions and connection to existing equipment.
  3. connection cubicle accessible through front, connection to the lower switch-disconnector and earthing switch terminals (IM cubicles) or the lower fuse-holders (PM and QM cubicles). This compartment is also equipped with an earthing switch downstream from the MV fuses for the protection units.
  4. operation mechanism, interlocking contains the elements used to operate the switch-disconnector and earthing switch and actuate the corresponding indications (positive break).
  5. Low voltage cubicle (upper & lower enclosure structure) installation of a terminal block (if motor option installed), LV fuses and compact relay devices. If more space is required, an additional enclosure may be added on top of the cubicle.
- Optional switch cubicles (IM) can also be fitted with:
6. control motorisation;
  - surge arrestors.

## Medium Voltage Switchgear YSM6-12~24 Air-insulated RMU(Fixed Type)



The three-phase rotary contact is installed in a gas chamber filled with SF6 gas and the relative pressure is 0.4bars. It has excellent operation performance with safety and reliability.

- Tightness:

The air chamber is filled with SF6 gas, which meets the standard requirements of "closed pressure system", and the sealing performance has been checked and inspected in the factory.

- Operational Safety:

1. The switch has three positions of "closed", "open" and "grounded", and has a locking function to prevent accidental operation. The contact is driven to rotate by the spring energy storage mechanism, which is not affected by human operation factors.
2. Has "break" and isolation functions.
3. The short-circuit making capacity of the SF6 grounding switch meets the standard requirements.
4. In the event of an accident, the pressure drops after the overpressured SF6 gas breaks through the safety diaphragm, and the gas will directly be sprayed into the back of the cabinet for safety.

Breaking Principle:

SF6 gas has excellent arc extinguishing performance. When the switch is opened, the relative movement between the arc and the gas will extinguish the arc. When the moving and static contacts are separated, the arc appears in the electromagnetic field generated by the permanent magnet, and the arc is elongated and extinguished when the current crosses zero by SF6 gas. The distance between the moving and static contacts is sufficient to withstand the recovery overvoltage. The system is simple and reliable, with minimal contact wear and long electrical life.

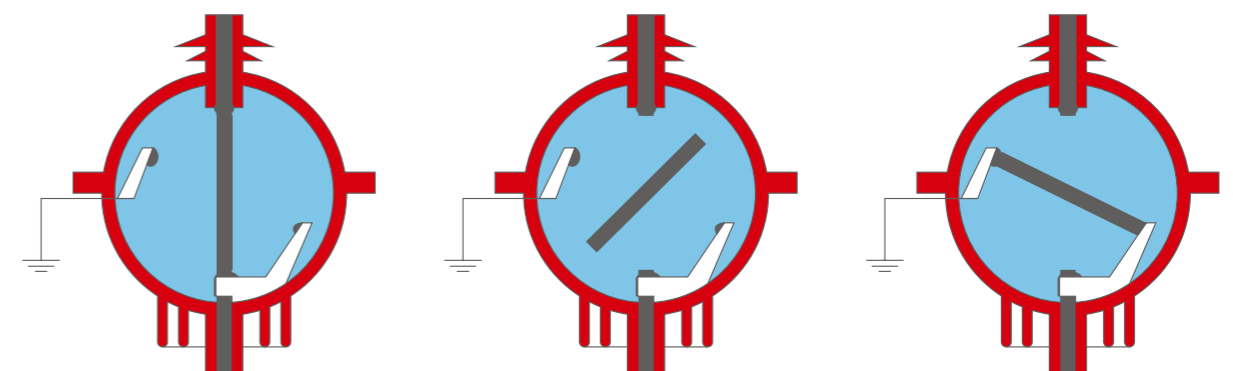

a) Earthing Position

b) Open Position

c) Closed Position

## Medium Voltage Switchgear

### YSM6-12~24 Air-insulated RMU(Fixed Type)

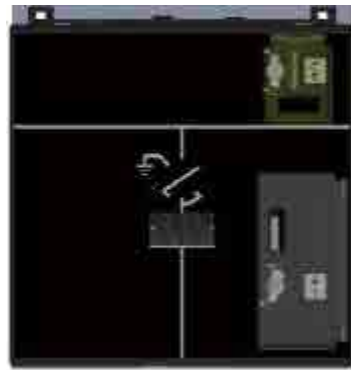

Cover for LBSkit 24 kV



Voltage Indicator

- Switchgear status indicator:  
Fitted directly to the drive shaft, these give a definite indication of the contact's position. (appendix A of standard IEC 62271-102).
- Operating lever:  
This is designed with an anti-reflex device that stops any attempt to reopen the device immediately after closing the switch or the earthing disconnecter.
- Locking device:  
Between one and three padlocks enable the following to be locked:
  - access to the switching shaft of the switch or the circuit breaker
  - access to the switching shaft of the earthing disconnecter
  - operating of the opening release push-button.
- Simple and effortless switching  
Mechanical and electrical controls are side by side on the front fascia, on a panel including the schematic diagram indicating the device's status (closed, open, earthed):
- Closed:  
the drive shaft is operated via a quick acting mechanism, independent of the operator. No energy is stored in the switch, apart from when switching operations are taking place.  
For combined switch fuses, the opening mechanism is armed at the same time as the contacts are closed.
- Opening:  
the switch is opened using the same quick acting mechanism, operated in the opposite direction.  
For a combined switch fuses unit, opening is controlled by:
  - a push-button
  - a fault.
- Earthing:  
a specific control shaft enables the opening or closing of the earthing contacts. Access to this shaft is blocked by a cover that can be slid back if the switch is open but which remains locked in place if it is closed.  
Voltage presence indicator  
This device has integrated VPIS (Voltage Presence Indicating System) type lights, in conformity with IEC standard 61958, enabling the presence (or absence) of voltage to be checked on the cables.  
Insensitivity to the environment
  - An internal sealed enclosure, contains the active parts of the LBSkit (switch, earthing disconnecter). It is filled with SF6 in accordance with the definitions in IEC recommendation 62271-200 for "sealed pressure systems".  
Sealing is systematically checked in the factory.
  - Parts are designed in order to obtain optimum electrical field distribution.

## Medium Voltage Switchgear

### YSM6-12~24 Air-insulated RMU(Fixed Type)

#### Overall and mounting dimensions(mm)

Matching Overall and mounting dimensions(mm) of SF6 load break switch-fuse combination

Fig 1) SF6 load break switch without upper cubicle

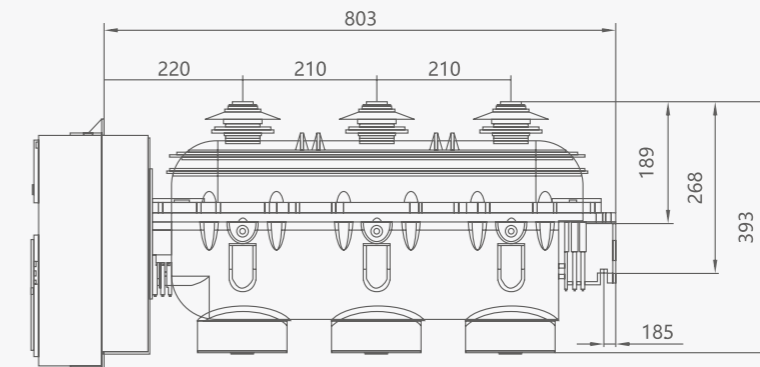

Lateral view of load break switch

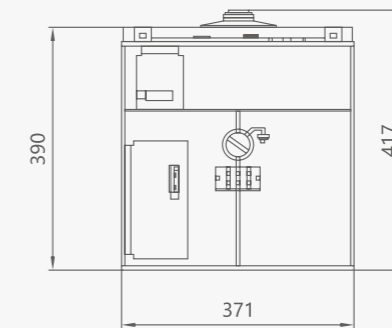

Frontal view of load break switch

Fig 2) Whole Load break switch outline

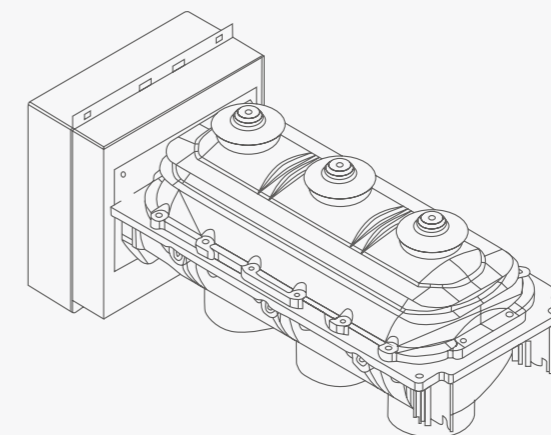

## Medium Voltage Switchgear **HXGN15A-12** Air-insulated RMU(Fixed Type)

- Rating: Rated voltage 3~12KV, rated current reach to 630A for load break switch and 125A for combined switchgear.
- Application: mainly applicable in urban power grid features and renovation project, industrial and mining enterprises, high-rise buildings and communal facilities .For power distribution, controlling and protection on electric equipment as the loop power supply unit or terminal equipment. It also can be installed in pre-loaded substation.
- Feature: Equipped with vacuum load switch and spring operating mechanism which can be operated by hand or electric. Grounding switch and insulating switch are equipped with hand operating mechanism .With small volume and high security.
- Standard: IEC60420

### General



## Medium Voltage Switchgear **HXGN15A-12** Air-insulated RMU(Fixed Type)

### Selection

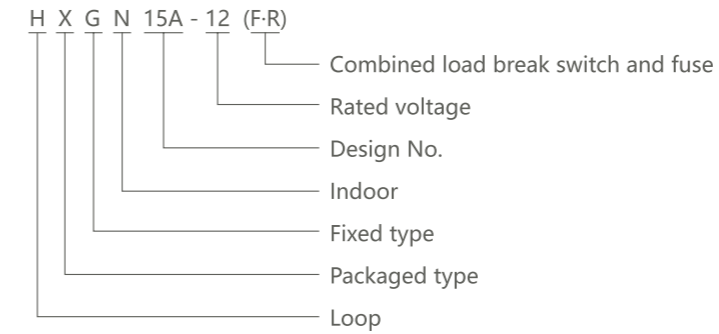

### Operating conditions

1. Ambient air temperature: -15°C~ +40°C.  
Daily average temperature: ≤35°C.
2. Altitude: ≤1000m.
3. Relative humidity : Daily average ≤95% ,daily average of vapour pressure ≤2.2kpa  
Monthly average ≤90%, monthly average of vapour pressure ≤1.8kpa.
4. Earthquake intensity: ≤magnitude 8.
5. Applicable in the places without corrosive and flammable gas.

Note: Customized products are available.

### Technical data

Sheet 1

No.	Item	Unit	Data	
1	Rated voltage	kV	12	
2	Rated current	Load break switchgear	A	630
		Combined switchgear	A	125
3	Rated short-circuit breaking current	kA	31.5	
4	Rated active on-load breaking current	A	630	
5	Rated short-time withstands current	kA	20	
6	Rated withstands current(Peak)	kA	50	
7	Rated power frequency voltage withstands inter-phase,to earth and to the open contact	kV	42/48	
8	Thundering withstands voltage inter-phase, to earth and to the open contact	kV	75/85	
9	Mechanical life	times	10000	
10	Rated take-over current	A	3150	
11	Operating mode	/	Manual or automatic	
12	Protection level	/	IP2X	

## Medium Voltage Switchgear HXGN15A-12 Air-insulated RMU(Fixed Type)

### Loop power supply principle

The loop power supply is composed of three basic unit to separate any one of the failure line and ensure the continuous power supply through the other unit. The branch line for the user could separated and protect the transformer which could facilitate the maintenance. The loop power supply could be expanded as per the user's requirements to form various protection plans.

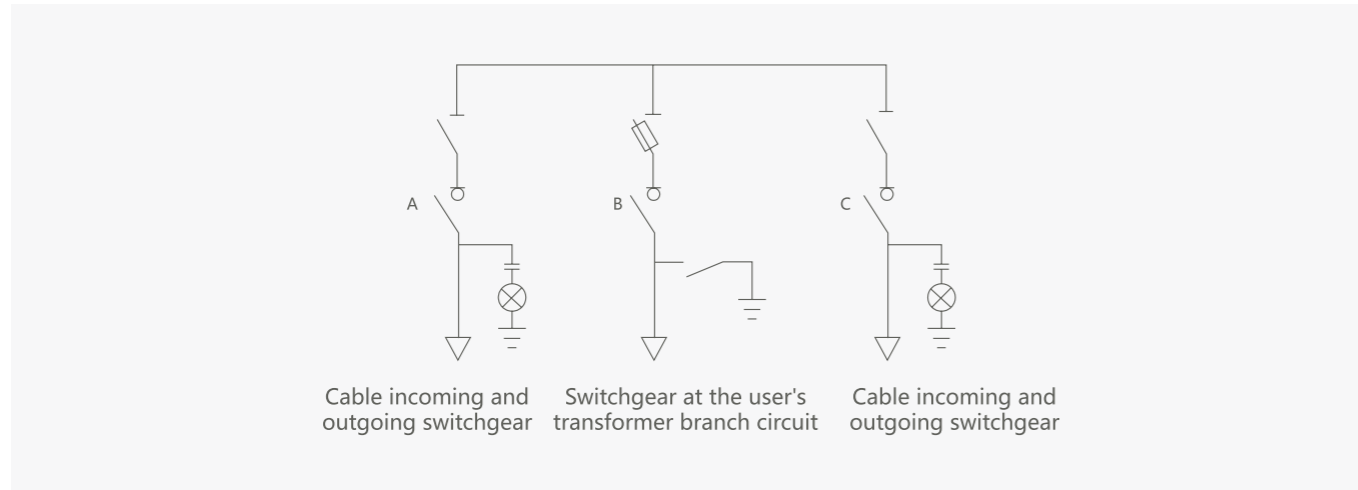

### Feature

1. 8MF material adopted for the switchgear ,modular holes available with E=200.
2. Switch disconnector ,vacuum load breaker switch, earthing switch and the switchgear door reliably interlocked ,which could avoid miss operation.
3. Both manual and automatic operation are available.
4. There is leas sealed pin at the door of measurement chamber and meter chamber.
5. Prompt tripping could be realized to protect the equipments.
6. The design facilitate the operation at the front panel and the switchgear could be installed alongside the wall.
7. The switchgear is featured for its complete interlocking function: the load break switch could be operated to the making status when the switchgear door is closed and locked and the earthing switch to the making position.  
When the earthing switch is at making status, input the insulation clapboard to its position, the switchgear door then, could be operated.
8. The Vacuum arc-extinguishing chamber and fuse are reliably connected. So as the fuse & switchgear door and insulation clapboard & the switchgear door.

## Medium Voltage Switchgear HXGN15A-12 Air-insulated RMU(Fixed Type)

Picture 2

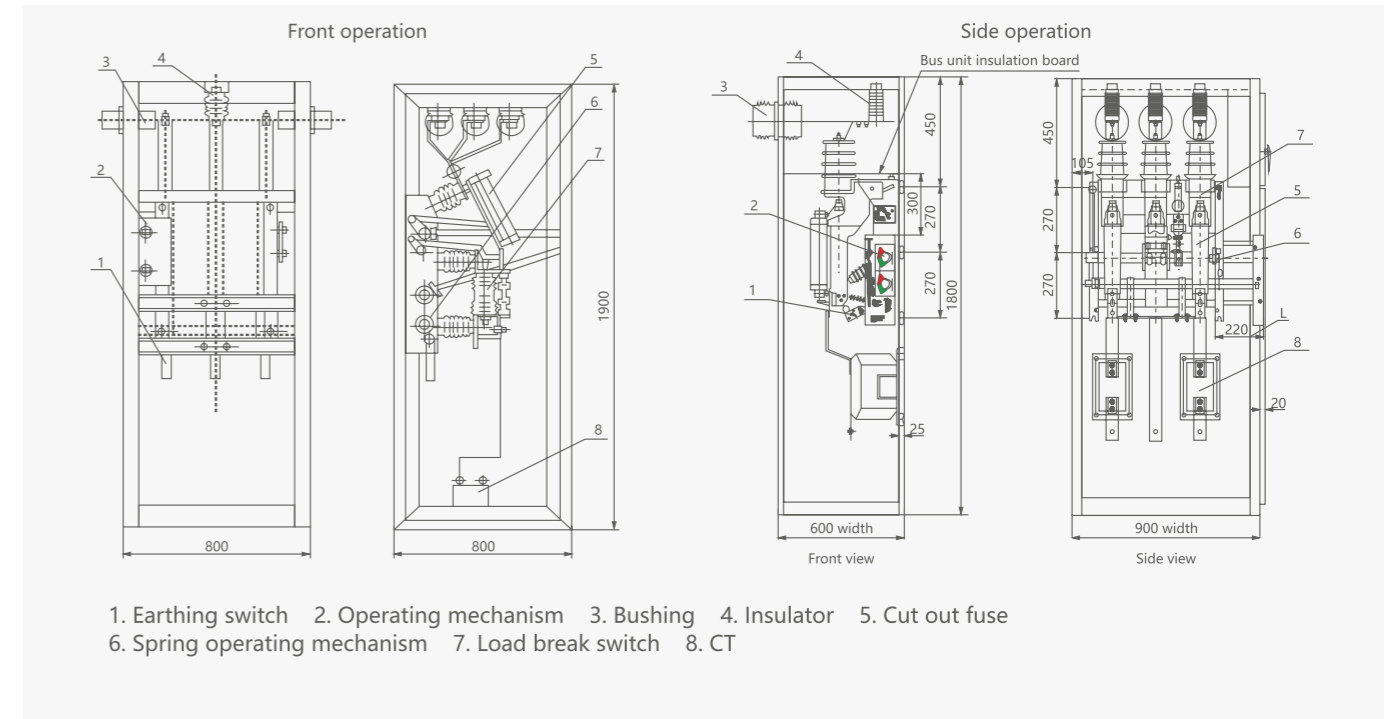

### Overall and mounting dimensions(mm)

Picture 3

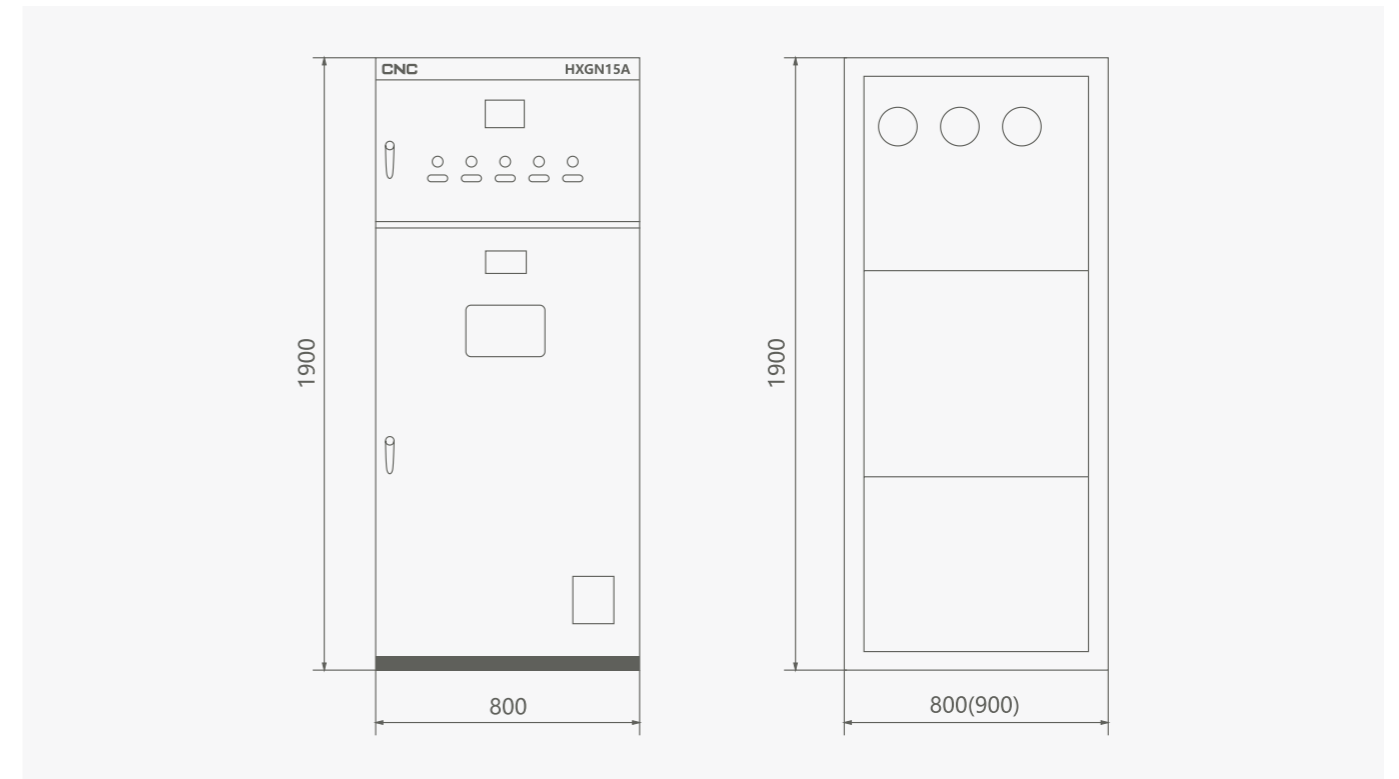

## Medium Voltage Switchgear HXGN15A-12 Air-insulated RMU(Fixed Type)

### Main single line diagram

Sheet 2

Program No.	01	02	03	04	05	06
Single line diagram						
Application	Cable incoming and outgoing feeder	Cable incoming and outgoing feeder	Cable incoming and outgoing feeder	Cable incoming and outgoing feeder	Cable incoming and outgoing feeder	Cable incoming and outgoing feeder
Isolation/Load/Combined apparatus	GN□-12D	GN□-12D	GN□-12D	GN□-12D	GN□-12D	GN□-12D
Fuse	/	RN3	/	/	/	/
Current transformer	/	/	/	/	LZZBJ9	LZZBJ9
Surge arrester	/	HY5W	/	/	/	/

Program No.	07	08	09	10	11	12
Single line diagram						
Application	Cable incoming and outgoing feeder	Cable incoming and outgoing feeder	Cable incoming and outgoing feeder	Cable incoming and outgoing feeder	Cable incoming and outgoing feeder	Cable incoming and outgoing feeder
Isolation/Load/Combined apparatus	FZN21-12D	FZN21-12D	FZN21-12D	FZN21-12D	FZN21-12D	FZN21
Fuse	/	/	/	RN2	RN2	RN2
Current transformer	/	LZZBJ9	LZZBJ9	/	LZZBJ9	LZZBJ9
Potential transformer	/	/	/	JDZ	JDZ	JDZ
Surge arrester	HY5W	HY5W	HY5W	/	/	/

Program No.	13	14	15	16	17	18
Single line diagram						
Application	Metering cable incoming	Metering cable incoming	Cable incoming and outgoing feeder	Cable incoming and outgoing feeder	Metering cable incoming	Overhead incoming cable outgoing
Isolation/Load/Combined apparatus	FZN21-12D	FZN21-12D	FZN21-12D	FZN21-12D	/	GN□-12D
Fuse	RN2	S□LAJ	S□LAJ	S□LAJ	RN2	RN3
Current transformer	LZZBJ9	/	LZZBJ9	LZZBJ9	LZZBJ9	/

## Medium Voltage Switchgear HXGN15A-12 Air-insulated RMU(Fixed Type)

Continued Sheet 2

Program No.	19	20	21	22	23	24
Single line diagram						
Application	Overhead incoming cable outgoing	Overhead incoming cable outgoing	Overhead incoming cable outgoing	Overhead incoming cable outgoing	Overhead incoming cable outgoing	Overhead incoming cable outgoing
Isolation/Load/Combined apparatus	FZN21-12D	FZN21-12D	FZN21-12D	FZN21-12D	FZN21-12D	FZN21-12D
Fuse	/	/	/	S□LAJ	S□LAJ	S□LAJ
Current transformer	/	LZZBJ9	LZZBJ9	/	LZZBJ9	LZZBJ9

Program No.	25	26	27	28	29	30
Single line diagram						
Application	Communication	Communication	Measure and Communication	Measure and Communication	Overhead incoming Communication	Overhead incoming Communication
Isolation/Load/Combined apparatus	FZN21-12D	FZN21-12D	/	/	FZN21-12D	FZN21-12D
Fuse	/	S□LAJ	RN2	RN2	/	S□LAJ
Current transformer	/	/	LZZBJ9	LZZBJ9	/	LZZBJ9
Potential transformer	/	/	JDZ	JDZ	/	/

Program No.	31	32	33	34	35	36
Single line diagram						
Application	Overhead incoming Communication	Measurement	Potential transformer	Potential transformer	Potential transformer	Potential transformer
Isolation/Load/Combined apparatus	/	/	GN□-12	GN□-12	GN□-12	GN□-12
Fuse	RN2	RN2	RN2	RN2	RN2	RN2
Current transformer	LZZBJ9	LZZBJ9	/	/	/	/
Potential transformer	JDZ	JDZ	JDZ	JDZJ	JDZJ	JDZJ
Surge arrester	/	/	/	/	HY5W	HY5W

# Medium Voltage Switchgear HXGN15A-12 Air-insulated RMU(Fixed Type)

## Single line diagram

Sheet 2

Program No.	01	02	03	04	05	06	07	08	
Single line diagram									
Application	Cable incoming	Left (right) communication	PT cable incoming	PT left (right) communication	Overhead incoming cable incoming	Overhead incoming left (right) communication	Cable outgoing	Cable outgoing	
Overall and mounting dimensions (mm) (Width×Depth×Height)	375×960×1600	375×960×1600	500×960×1600	500×960×1600	375×960×1600	375×960×1600	375×960×1600	500×960×1600	
Main electrical components	Type	QTY.							
	FLN36-12D/630-20	1	1	1	1	1	1	/	/
	FLN36-12D/125-31.5	/	/	/	/	/	/	1	1
	RN2-0.05A	/	/	3	3	/	/	/	/
	SDLDJ/SFLDJ/SKLDJ	/	/	/	/	/	/	3	3
	LZZS-10Q LZZB9-10C LZZB-10	2 or 3	2 or 3	/	/	2 or 3	2 or 3	/	1 / 2 / 3
	JDZX10-10A JDZ8-10	/	/	2 or 3	2 or 3	/	/	/	/
	HY5WZI-17/45	/	(3)	/	/	/	/	/	/
	DZN4-T1.2	1	1	1	1	1	1	1	1

# Medium Voltage Switchgear HXGN15A-12 Air-insulated RMU(Fixed Type)

Continued sheet 2

Program No.	09	10	11	12	13	14	15	16	
Single line diagram									
Application	Metering cable incoming	Metering cable incoming	Measurement	Measurement	Cable incoming	Bus elevated	Overhead incoming cable outgoing	Overhead incoming cable outgoing	
Overall and mounting dimensions (mm) (Width×Depth×Height)	500×960×1600	500×960×1600	375×960×1600	375×960×1600	375×960×1600	375×960×1600	375×960×1600	500×960×1600	
Main electrical components	Type	QTY.							
	FLN36-12D/630-20	/	/	/	/	/	/	/	/
	FLN36-12D/125-31.5	/	/	/	/	/	/	1	1
	RN2-0.05A	3	3	3	3	/	/	/	/
	SDLDJ/SFLDJ/SKLDJ	/	/	/	/	/	/	3	3
	LZZS-10Q LZZB9-10C LZZB-10	2 or 3	2 or 3	2 or 3	2 or 3	/	/	/	1 / 2 / 3
	JDZX10-10A JDZ8-10	2 or 3	2 or 3	2 or 3	2 or 3	/	/	/	/
	HY5WZI-17/45	3	/	/	/	(3)	/	/	/
	DZN4-T1.2	1	/	/	/	1	/	1	1



## Medium Voltage Switchgear YVG-12 Solid Insulation Ring Network Cabinet

- YVG-12 series solid insulation ring network switchgear is a fully insulated, fully sealed, and maintenance free solid insulation vacuum switchgear.
- The ring network cabinet has the characteristics of simple structure, flexible operation, reliable interlocking, and convenient installation, and is suitable for 50Hz, 12 kV power systems. It is widely used in industrial and civil cable ring networks and distribution network terminal projects, as a means of receiving and distributing electricity, especially suitable for urban residential distribution, industrial and mining enterprises. Used in airports, subways, wind power generation, tunnels, and other places.
- Suitable for use in areas with harsh environments such as high altitude, high temperature, humid heat, severe pollution, etc.
- Standards: IEC62271-1-200 IEC62071-2000-2003

### General



## Medium Voltage Switchgear YVG-12 Solid Insulation Ring Network Cabinet

### Selection

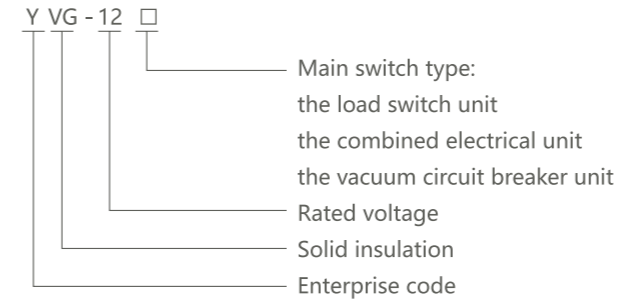

Classified by functional units in the system: incoming cabinet, outgoing cabinet, buscouple cabinet, metering cabinet, PT cabinet, lifting cabinet, etc., represented by wiring scheme number. According to the type of main switch components, it is divided into: load switch cabinet, load switch fuse combination electrical cabinet, circuit breaker cabinet, and isolation switch cabinet, etc., represented by F (fuse combination electrical appliance), V (circuit breaker), C (loadswitch), etc

### Operating conditions

- Ambient Temperature: No more than +45°C, No less than -45°C. Average temperature no more than +35°C within 24 hours.
- Altitude: No more than 3000m.
- Relative Humidity: the average daily value is no more than 95%, the average monthly value is no more than 90%.
- Earthquake Intensity: No more than 8 degrees.
- Vapor Pressure: the average daily value is no more than 2.2kPa, and the average monthly value is no more than 1.8kPa.
- Installation locations without fire, explosion danger, serious pollution, chemical corrosion and violent vibration.

### Technical data

Item	Unit	C Module	F Module	V Module	
		Load switch	Load switch with fuse	Vacuum switch	Disconnecter/ Earthing Switch
Rated voltage	kV	12	12	12	12
Rated frequency 1min	Hz	50/60	50/60	50/60	50/60
Power frequency withstand voltage in 1 min	kV	42/48	42/48	42/48	42/48
Lightning impulse withstand voltage(Peak)	kV	75/85	75/85	75/85	75/85
Rated current	A	630	note <sup>1)</sup>	630	/
Rated closed loop breaking current	A	630	/	/	/
Rated cable charging breaking current	A	10	/	/	/
Rated short circuit making current	A	50	80	50	50
Rated peak withstand current	kA	50	/	50	/
Rated short time withstand current	kA/3S	20	/	20	/
Rated short circuit breaking current	kA	/	31.5	20	/
Rated transfer current	A	/	1700	/	/
Max. rated current of fuse	A	/	125	/	/
Loop resistance	μΩ	≤200	≤500	/	/
Mechanical life	times	5000	3000	5000	2000

Note: 1) Depends on the rated current of the fuse

## Medium Voltage Switchgear

### YVG-12 Solid Insulation Ring Network Cabinet

#### Feature

1. YVG-12 switchgear mainly has three functional units, namely V unit(circuit breaker unit), C unit (load switch unit), F unit (combined electrical unit), when the system requires multiple units to be configured , can be arbitrarily expanded on the left and right sides, and can be arranged arbitrarily according to different design schemes to achieve different configuration requirements.
2. Each unit is structurally divided into three parts: instrument room,operating mechanism and primary circuit. The instrument room can be equipped with microcomputer protection (intelligent controller) and other meters. The operating mechanism is a special spring operation mechanism,which can also be equipped with additional Electric operating mechanism;the primary circuit adopts APG automatic gel technology, and the busbar,isolating switch and arc extinguishing chamber are completely sealed in epoxy resin, and there are special joints connected to the busbar.
3. YVG-12 solid insulation switchgear has the advantages of compact structure, full insulation, long life, maintenance-free, small space occupation, safety and reliability, and is not affected by the working environment. It is widely used in industrial and civil ring network and terminal power supply .

#### Design scheme

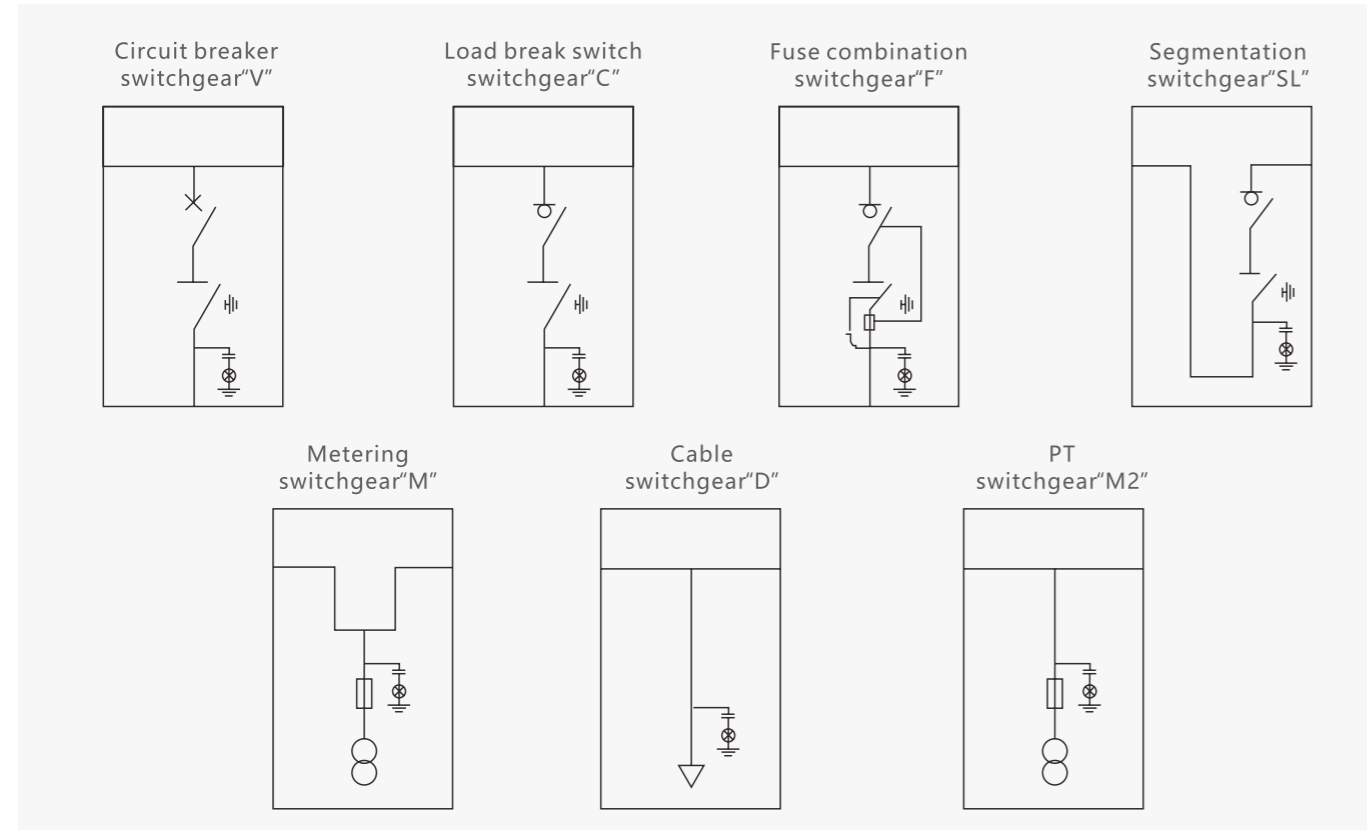

## Medium Voltage Switchgear

### YVG-12 Solid Insulation Ring Network Cabinet

#### Overall and mounting dimensions(mm)

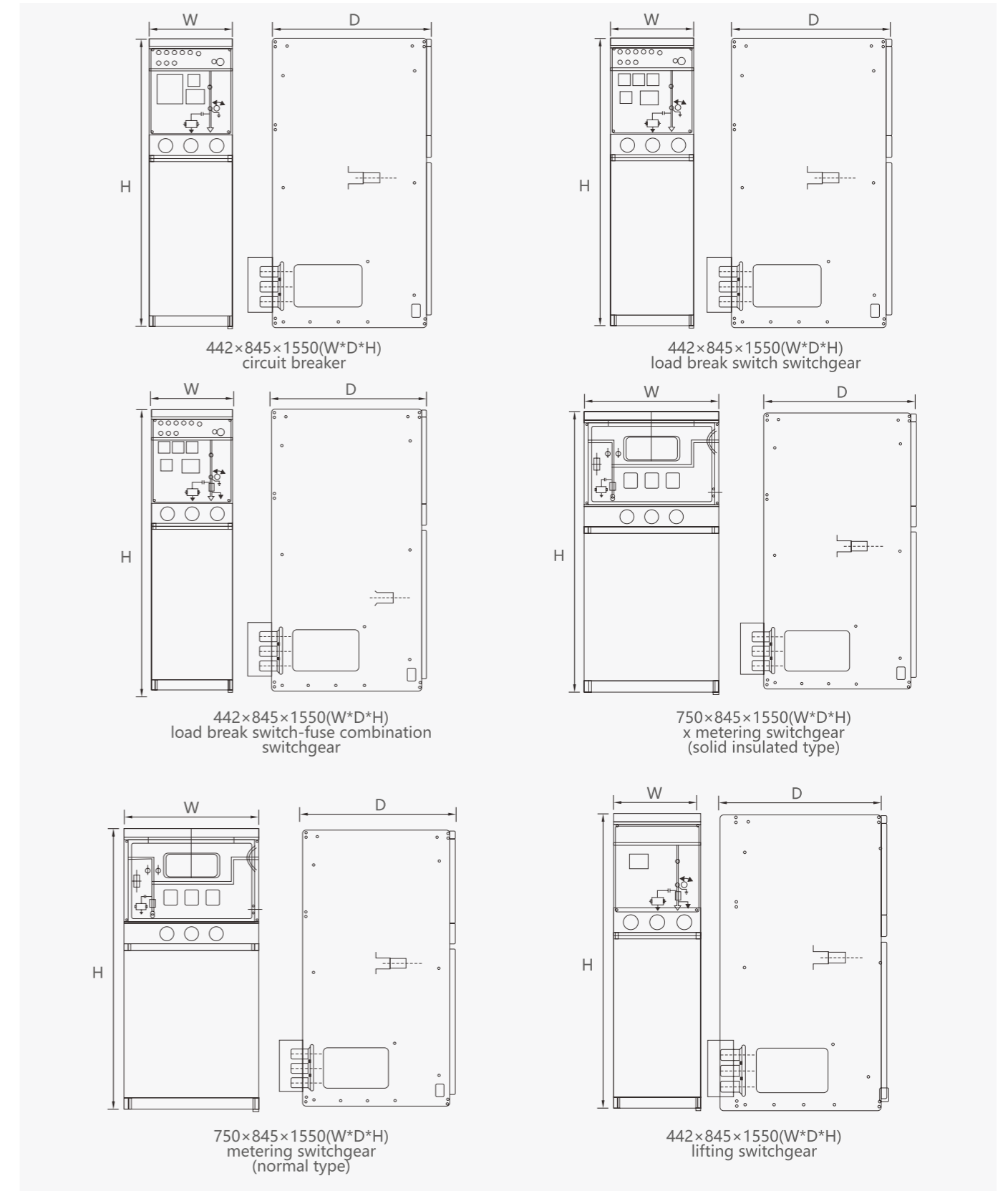

Medium Voltage Switchgear  
**YVG-12 Solid Insulation Ring Network Cabinet**

POWER TRANSMISSION AND  
 DISTRIBUTION PRODUCT SELECTION

PROFESSIONAL MANUFACTURER OF  
 HIGH AND LOW VOLTAGE PRODUCTS

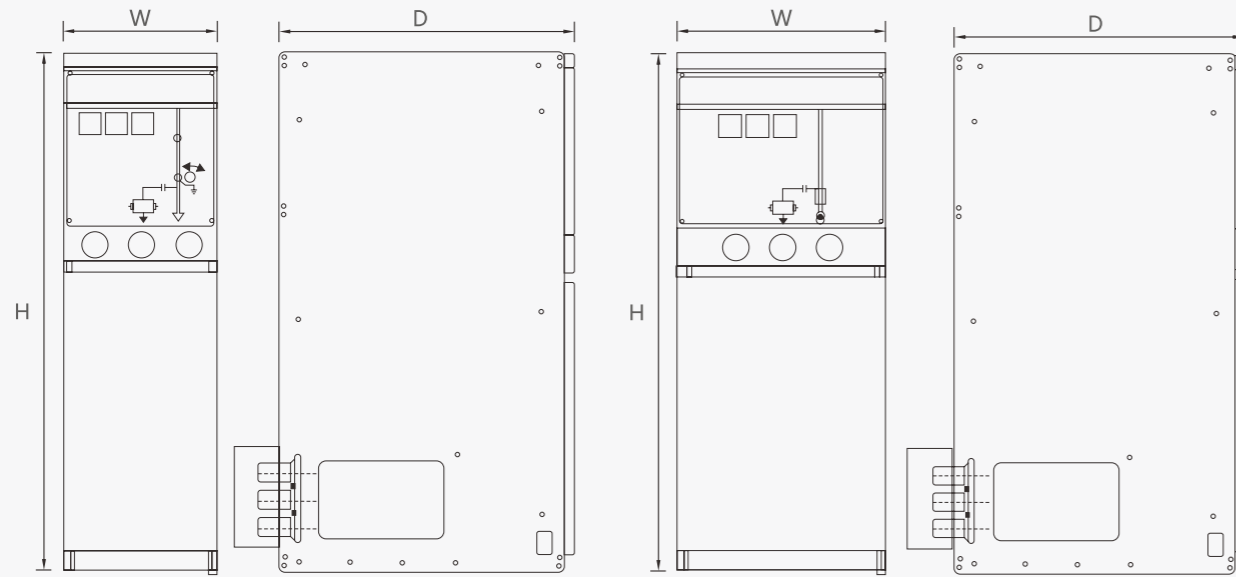

442×845×1550(W\*D\*H)  
 PT switchgear with disconnector  
 (solid insulated type)

600×845×1550(W\*D\*H)  
 PT switchgear without disconnector  
 (normal type)

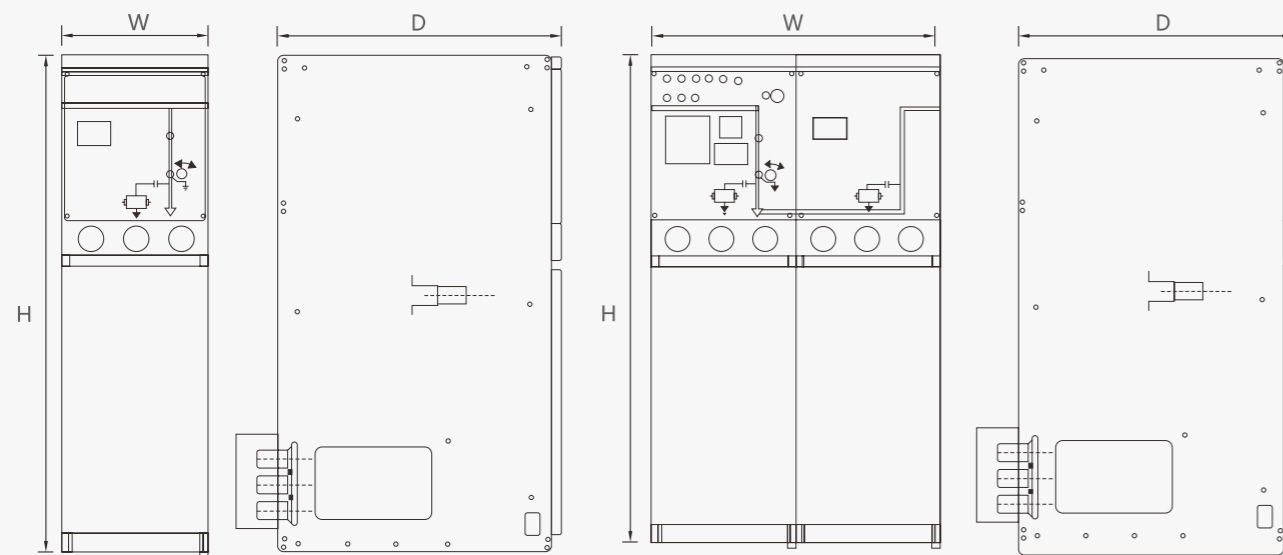

442×845×1550(W\*D\*H)  
 disconnector switchgear

884×845×1550(W\*D\*H)  
 lifting switchgear

Medium Voltage Switchgear  
**YRM6-12/24 Gas-insulated Metal-enclosed Switchgear**

- YRM6 fully insulated fully enclosed compact switchgear, which can realize functions of control, protection, measurement, monitoring, communication, etc. is especially suitable for places with small distribution facility site and high reliability requirements, and places with a relatively harsh natural environment and conditions. such as underground, highland and coastal areas.
- It is mainly used in areas where land is tight and space is limited, high reliability is required, like industrial and mining enterprises and substations, subways, light rail railways, etc

General



## Medium Voltage Switchgear

### YRM6-12~24 Gas-insulated Metal-enclosed Switchgear

#### Selection

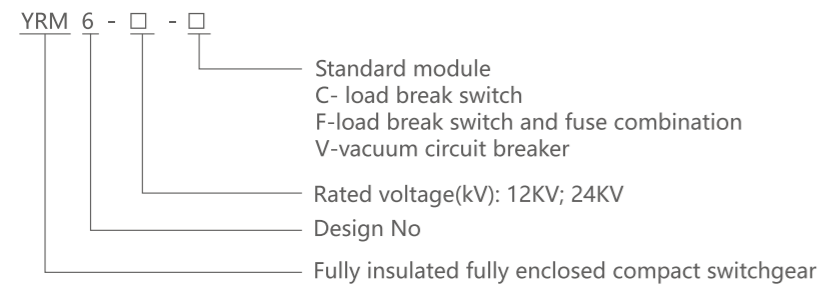

#### Operating conditions

1. Ambient air temperature:  $-40^{\circ}\text{C}\sim+40^{\circ}\text{C}$ ;
2. Relative air humidity: daily average <95%, monthly average <90%;
3. Altitude  $\leq 1500\text{m}$  (under standard inflation pressure);
4. Seismic intensity <9 class;
5. Places free from fire, explosion, serious contamination, chemical corrosion and severe vibration.

#### Special conditions

Manufacturers and end users must agree on special Operating conditions that are different from normal operating conditions;

If a particularly harsh operating environment is involved, the manufacturer and supplier must be consulted;

When electrical equipment is installed at an altitude of 1500 meters or more, special instructions are required to adjust the pressure during manufacturing. When the pressure is adjusted, the life of the switchgear itself has no significant effect.

#### Features

##### • Modular design

The switch is divided into fixed module and expandable module group. In the same SF6 insulated air chamber, up to 6 modules can be configured. Switching cabinets with more than 6 modules must be connected with the expansion busbar to realize the semi-module.

Structure, full module configuration can also be achieved by using an extended bus between all modules. Through the combination of different functional modules, a simple to complex power distribution scheme can be formed to meet various configuration requirements in the secondary substation and the opening and closing.

## Medium Voltage Switchgear

### YRM6-12~24 Gas-insulated Metal-enclosed Switchgear

##### • Compact structure

Except for the air-insulated metering cabinet, all modules are only 325mm wide and the metering cabinet width is 695mm; the cable joints of all units are the same height to the ground, which is convenient for on-site Features.

##### • Unaffected by the environment

All high-voltage live parts are installed in a sealed stainless steel case. The case is welded with a stainless steel plate and filled with SF6 gas at a working pressure of 1.4 bar. The degree of protection is IP67. It can be used in places where it is installed in damp, dusty, salt spray, mine, box-type substation and air pollution. Even the fuse compartment has an IP67 rating. The extension busbars are completely insulated and shielded to ensure that they are not affected by changes in the external environment.

##### • Highly reliable personal safety

All live parts are enclosed in the SF6 air chamber, the switch has a reliable pressure relief channel, the load and grounding switches are three-position switches, simplifying the interlocking between each other, reliable mechanical interlock between the cable compartment cover and the load switch .

#### Performance Index

- SF6 gas pressure: 1.4bar under  $20^{\circ}\text{C}$  (absolute pressure)
- Annual leakage rate: 0.25%/year
- Protection grade
  - SF6 gas room: IP67
  - Fuse tube: IP67
- Switchgear enclosure: IP3X
- Busbar
  - Switchgear internal busbar:  $400\text{mm}^2\text{Cu}$
  - Switchgear earthing busbar:  $150\text{mm}^2\text{Cu}$
  - Thickness of gas room stainless steel enclosure: 3.0mm
- The front panel and the side panel of the switchgear, and the front cover of the cable room, the company's standard color is: jade color 7783; if users have special requirements, please put forward when ordering.

## Medium Voltage Switchgear YRM6-12~24 Gas-insulated Metal-enclosed Switchgear

### Standard

- High-voltage alternating-current circuit-breakers (IEC 62271-100:2001, MOD)
- High-voltage alternating-current disconnectors and earthing switches (IEC 62271-102:2002,MOD)
- Common specifications for high-voltage switchgear and controlgear standards
- High-voltage alternating-current switches for rated voltage above 3.6kV and less than 40.5kV(IEC60265-1-1998,MOD)
- Alternating-current metal-enclosed switchgear and controlgear for rated voltages above 3.6kV and up to and including 40.5kV (IEC62271-200-2003, MOD)
- Degrees of protection provided by enclosure (IP code) (IEC 60529-2001,IDT)
- High-voltage alternating current switch-fuse combinations (IEC6227-105-2002,MOD)
- DL/T 402 Specification of high-voltage alternating-current circuit-breakers (IEC 62271-100-2001,MOD)
- DLT 403 HV vacuum circuit-breaker for rated voltage 12kv to 40.5kv
- DLT404 Alternating-current metal-enclosed switchgear and controlgear for rated voltages above 3.6kV and up to and including 40.5kV
- DL/T 486 HVAC disconnectors and earthing switches (IEC62271-102-2002,MOD)
- DLT593 Common specifications for high-voltage switchgear and controlgear standards IEC 60694-2002,MOD)
- DLT 728 Technical guide for the order of gas-insulated metal-enclosed switchgear (IEC815-1986, IEC 859-1986)
- DL/T 791 Specification of indoor AC HV gas-filled switchgear panel

### Technical data

NO.	Items	Unit	Value		
			Load break switch	Combination	Vacuum circuit breaker
1	Rated voltage	kV	12/24		
2	Rated frequency	Hz	50/60		
3	Power frequency withstand voltage	phase-to-phase	A	60	630/1250
		across open contacts	kV	42/65	
4	Lightning impulse withstand voltage	phase-to-phase	kV	75/125	
		across open contacts	kV	85/145	
5	Rated short time withstand current	KA/4s	20/20	/	20/25
6	Rated peak withstand current	KA	50/50	/	50/63
7	Rated short circuit making current (peak)	KA	50/50	80/80	50/63
8	Rated short circuit current	KA	/	31.5/31.5	20/25
9	Rated transfer current	A	/	1700/1400	/
10	Rated closed-loop breaking current	A	630/630	/	/
11	Rated cable charging breaking current	A	10/25	/	/
12	Mechanical life	Times	5000	3000	5000

Note 1: depends on the rated current of fuse.

## Medium Voltage Switchgear YRM6-12~24 Gas-insulated Metal-enclosed Switchgear

### Standard modules

Each module of the YRM6 type switchgear has the following configurations :

- D cabinet - lifting module  
See standard configuration and features in "cable connection module without grounding knife"
- C cabinet - load switch module  
See standard configuration and features in "load switch module"
- F cabinet-load switch and fuse combination module  
See standard configuration and characteristics in "load switch and fuse combination module"
- V cabinet - vacuum switch module  
See standard configuration and features in "vacuum switch module"
- Capacitive voltage indicator for the incoming bushing  
Install a pressure gauge that monitors SF6 density in each chamber
- Lifting lug
- Operating handle

### Optional configurations

Electric operating mechanism/cable short circuit and ground fault indicator/current transformer and meter

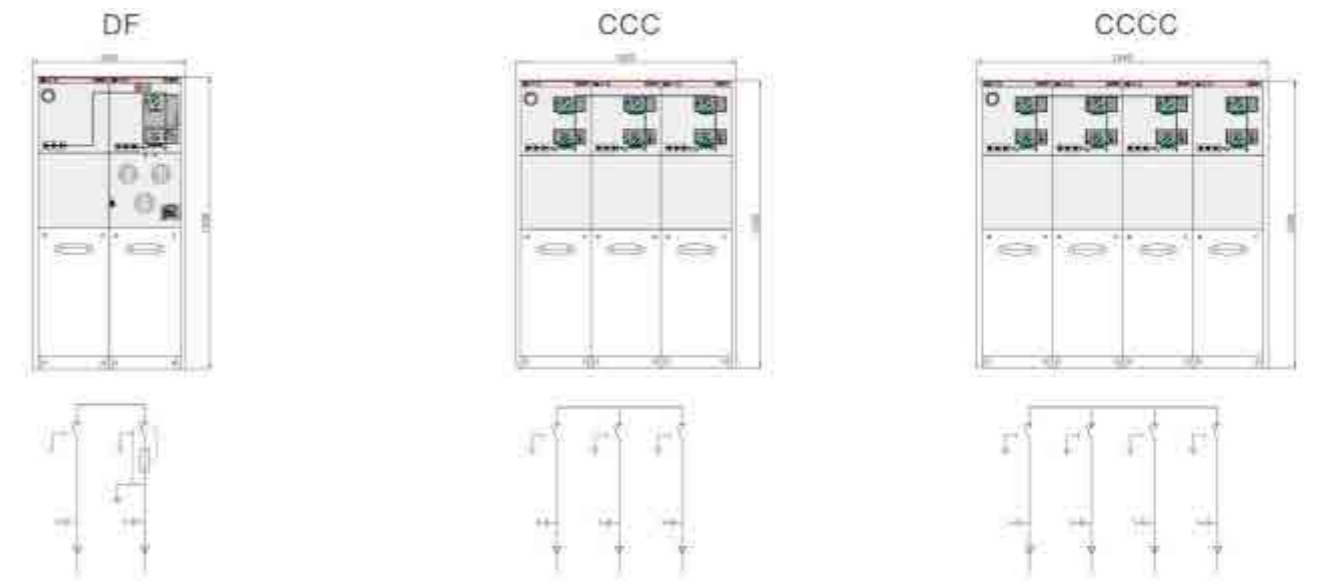

Standard 2 circuits DF (260kg)

Standard 2 circuits CCC (3000kg)

Medium Voltage Switchgear  
**YRM6-12~24 Gas-insulated Metal-enclosed Switchgear**

Optional configurations

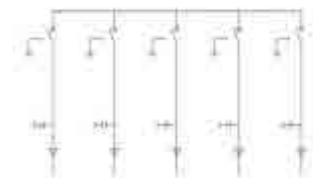
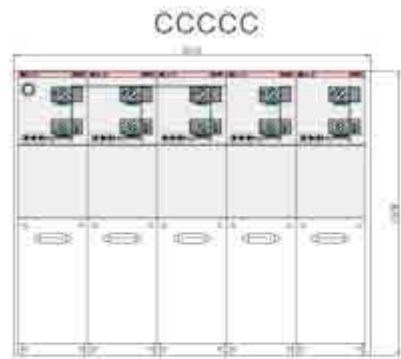

Standard 5 circuits CCCCC (480kg)

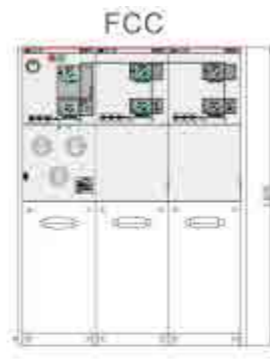

Standard 3 circuits FCC (320kg)

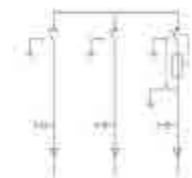
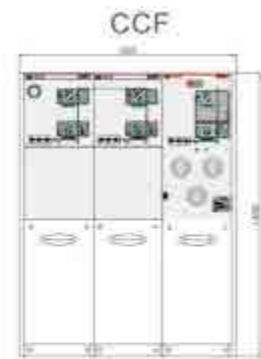

Standard 3 circuits CCF (320kg)

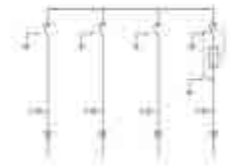
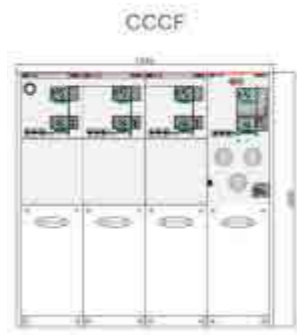

Standard 4 circuits CCCF (410kg)

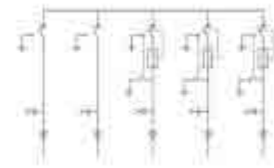

Standard 5 circuits CCFF (540kg)

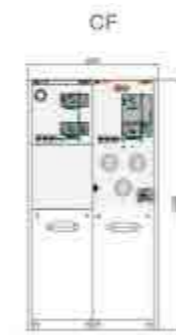

Standard 2 circuits CF (270kg)

Medium Voltage Switchgear  
**YRM6-12~24 Gas-insulated Metal-enclosed Switchgear**

Optional configurations

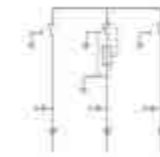
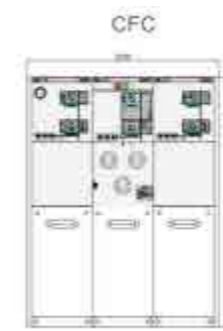

Standard 3 circuits CFC (320kg)

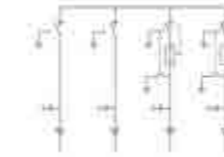
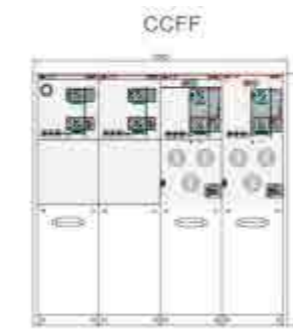

Standard 4 circuits CCFF (430kg)

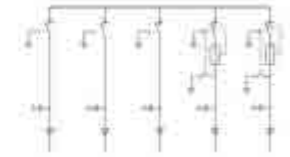

Standard 5 circuits CCGFF (520kg)

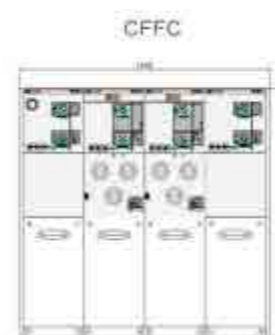

Standard 4 circuits CFFC (430kg)



Standard 4 circuits CCVV (411kg)

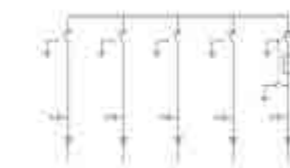

Standard 5 circuits CCCCFF (500kg)

## Medium Voltage Switchgear

### YRM6-12~24 Gas-insulated Metal-enclosed Switchgear

#### Standard expansion modules

Available modules

Model	Name	12KV cabinet width	24KV cabinet width
C	Load switch module	Width=325mm	Width=375mm
D	Cable connection module without grounding knife	Width=325mm	Width=375mm
F	Load switch fuse combination electrical module	Width=325mm	Width=375mm
V	Vacuum circuit breaker module	Width=325mm	Width=375mm
SL	Busbar segmentation switch module (load switch)	Width=325mm	Width=375mm
SVBR	Busbar segmentation switch module (vacuum circuit breaker) Sv is always with the bus lifting module	Width=650mm	Width=650mm
M	Meter module 12kV	Width=695mm	Width=695mm
PT	Module	Width=370 or 695mm	Width=370 or 695mm

Note: A single module must add extension before it can be used.



## Medium Voltage Switchgear

### YRM6-12~24 Gas-insulated Metal-enclosed Switchgear

#### Expansion module-load switch module C

##### Standard configuration and characteristics

- 630A internal bus
- Three working-position load/earth switch
- Three working-position single-spring operating mechanism, with two independent load switch and earth switch operating shafts
- Load switch and earth switch position indication
- Outgoing bushing in front horizontal arrangement, 630A 400 series bolted bushing
- Capacitive voltage indicator indicating that the bushing is live
- For all switch functions, there is a convenient add-on padlock on the panel
- SF6 gas pressure gauge (only one in each SF6 gas box)
- Ground busbar
- Interlocking of the earth switch to the front panel of the cable compartment

##### Optional configuration and characteristics

- Reserved bus extension
- External bus
- Load switch operation motor 110V/220V DC/AC
- Short circuit and ground fault indicator
- Measure toroidal current transformer and ammeter
- Meter toroidal current transformer and watt-hour meter
- A lightning arrester or double cable head can be installed at the cable incoming bushing
- Key interlocking1
- Incoming live grounding lock (lock the earth switch when the bushing is energized)  
110V/220VAC
- Auxiliary contacts  
Load switch position 2NO+2NC  
Earth switch position 2NO+2NC  
Pressure gauge with signal 1 NO  
Arc extinguisher with signal contact 1 NO
- Secondary device can be installed in  
Secondary line chamber at the top of the switchgear  
Low voltage box at the top of the switchgear

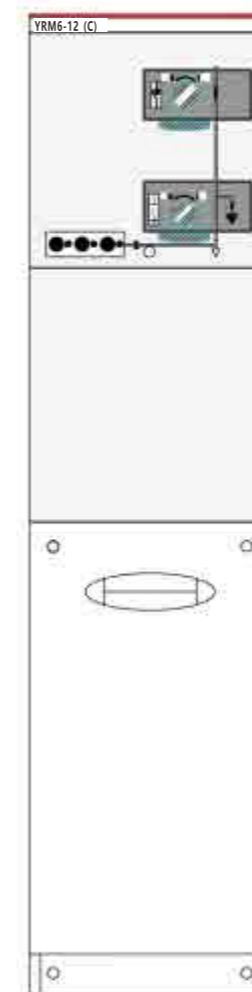

**YRM6-12~24 Gas-insulated Metal-enclosed Switchgear**

**Expansion module-without grounding knife module D**

**Standard Configuration and Characteristics**

- 630A internal bus
- Outgoing bushing in front horizontal arrangement, 630A 400 series bolted bushing
- Capacitive voltage indicator indicating that the bushing is live
- SF6 gas pressure gauge (only one in each SF6 gas box)
- Ground busbar

**Optional configuration and characteristics**

- Reserved bus extension
- External bus
- Short circuit and ground fault indicator
- Measure toroidal current transformer and ammeter
- Meter toroidal current transformer and watt-hour meter
- A lightning arrester or double cable head can be installed at the cable incoming bushing
- Secondary device can be installed in  
Secondary line chamber at the top of the switchgear  
Low voltage box at the top of the switchgear

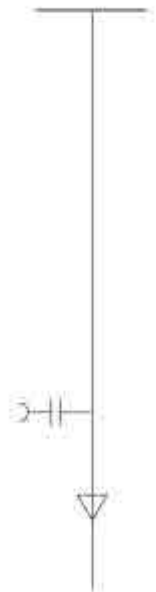
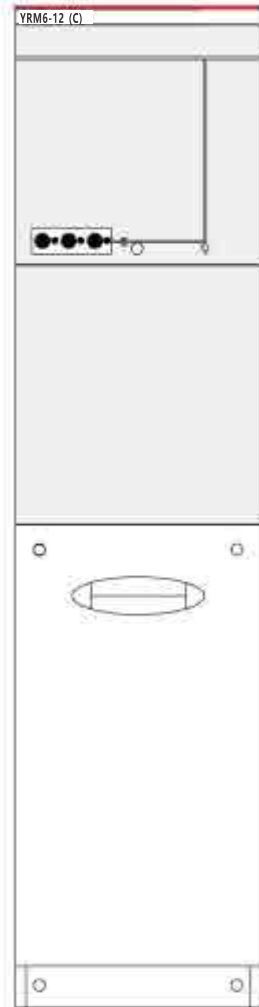

**YRM6-12~24 Gas-insulated Metal-enclosed Switchgear**

**Expansion module-load switch and fuse combination module F**

**Standard Configuration and Characteristics**

- 630A internal bus
- Three working-position load switch, the fuse head end is mechanically linked with the fuse tail end earth switch
- Three working-position double-spring operating mechanism, with two independent load switch and earth switch operating shafts
- Load switch and earth switch position indication
- Fuse tube
- Fuse placed horizontally
- Fuse tripping indication
- Outgoing bushing in front horizontal arrangement, 200A 200 series plug-in bushing
- Capacitive voltage indicator indicating that the bushing is live
- For all switch functions, there is a convenient add-on padlock on the panel
- SF6 gas pressure gauge (only one in each SF6 gas box)
- Ground busbar
- Fuses for transformer protection parameter 12kV max.125A fuse
- Interlocking of the earth switch to the front panel of the cable compartment

**Optional configuration and characteristics**

- Reserved bus extension
- External bus
- Load switch operation motor 110/220V DC/AC
- Paralleling tripping coil 110/220V DC/AC
- Paralleling closing coil 110/220V DC/AC
- Measure toroidal current transformer and ammeter
- Meter toroidal current transformer and watt-hour meter
- Incoming live grounding lock (lock the earth switch when the bushing is energized)  
110V/220V AC
- Auxiliary contacts  
Load switch position 2NO+2NC  
Earth switch position 2NO+2NC  
Pressure gauge with signal 1 NO  
Fuse blown 1 NO
- Secondary device can be installed in  
Secondary line chamber at the top of the switchgear  
Low voltage box at the top of the switchgear

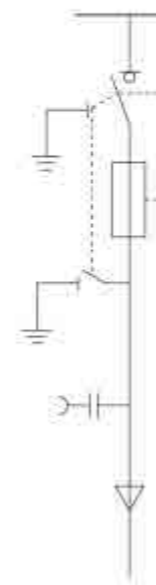



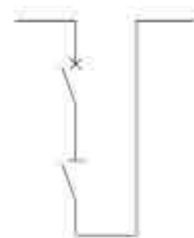
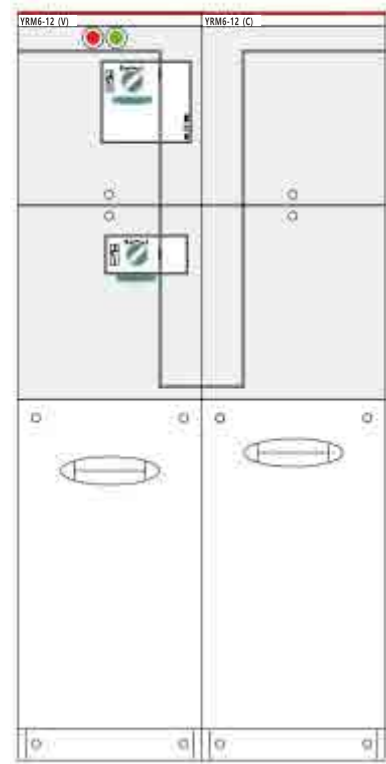

**Expansion module-busbar sectional switch module (circuit breaker) SVBR**

**Standard configuration and characteristics**

- 630A internal bus
- 630A vacuum circuit breaker
- Two working-position double-spring operating mechanism for vacuum circuit breaker
- Vacuum circuit breaker lower disconnect switch
- Disconnect switch single-spring operating mechanism
- Mechanical interlocking of vacuum circuit breaker and disconnect switch
- Vacuum circuit breaker and disconnect switch position indication
- For all switch functions, there is a convenient add-on padlock on the panel
- SF6 gas pressure gauge (only one in each SF6 gas box)
- SV is always connected to the busbar lifting switchgear, occupying two module widths together

**Optional configuration and characteristics**

- Reserved bus extension
- External bus
- Vacuum circuit breaker operation motor 110V/220V DC/AC
- Paralleling tripping coil 110/220V DC/AC
- Paralleling closing coil 110/220V DC/AC
- Key interlocking
- Auxiliary contacts  
Circuit breaker position 2NO+2NC  
Disconnect switch position 2NO+2NC
- Secondary device can be installed in  
Secondary line chamber at the top of the switchgear  
Low voltage box at the top of the switchgear

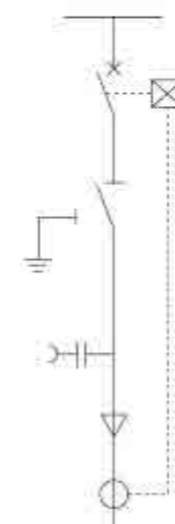
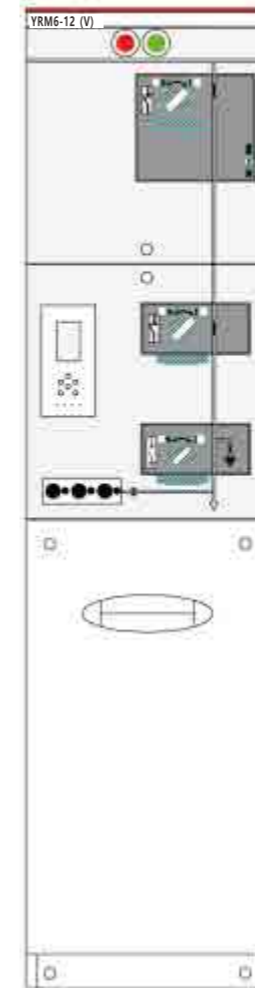

**Expansion module - vacuum circuit breaker module V**

**Standard configuration and characteristics**

- 630A internal bus
- 630A transformer/line protection vacuum circuit breaker
- Two working-position double-spring operating mechanism for vacuum circuit breaker
- Vacuum circuit breaker lower three working-position disconnect/earth switch
- Three working-position disconnect earth switch single-spring operating mechanism
- Mechanical interlocking of vacuum circuit breaker and three working-position switch
- Vacuum circuit breaker and three working-position switch position indication
- Electronic protection relay
- Trip coil (for relay action)
- Outgoing bushing in front horizontal arrangement, 630A 400 series bolted bushing
- Capacitive voltage indicator indicating that the bushing is live
- For all switch functions, there is a convenient add-on padlock on the panel
- SF6 gas pressure gauge (only one in each SF6 gas box)
- Ground busbar
- Interlocking of the earth switch to the front panel of the cable compartment

**Optional configuration and characteristics**

- Reserved bus extension
- External bus
- Vacuum circuit breaker operation motor 110V/220V DC/AC
- Paralleling tripping coil 110/220V DC/AC
- Paralleling closing coil 110/220V DC/AC
- Measure toroidal current transformer and ammeter
- Meter toroidal current transformer and watt-hour meter
- Incoming live grounding lock (lock the earth switch when the bushing is energized) 110V/220V AC
- Key interlocking
- Auxiliary contacts  
Vacuum switch position 2NO+2NC  
Disconnect switch position 2NO+2NC  
Earth switch position 2NO+2NC  
Vacuum switch trip signal 1 NO  
Pressure gauge with signal 1 NO
- Secondary device can be installed in  
Secondary line chamber at the top of the switchgear  
Low voltage box at the top of the switchgear
- Other relays such as SPAJ140C

**YRM6-12~24 Gas-insulated Metal-enclosed Switchgear**

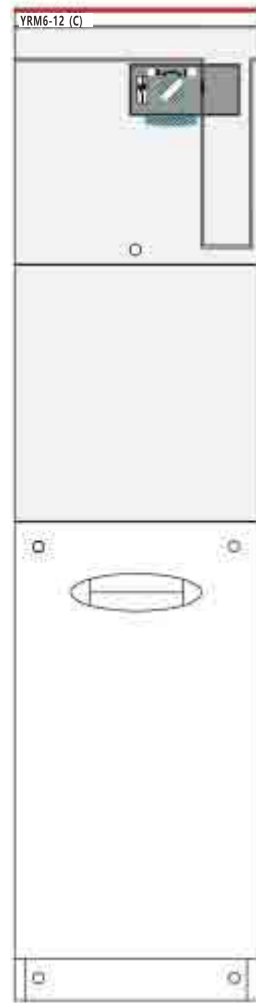

**Expansion module-busbar sectional switch module (load switch)SL**

**Standard configuration and characteristics**

- 630A internal bus
- Disconnect switch
- Single-spring operating mechanism
- Switch position indication
- For all switch functions, there is a convenient add-on padlock on the panel
- SF6 gas pressure gauge (only one in each SF6 gas box)

**Optional configuration and characteristics**

- Reserved bus extension
- External bus
- Load switch operation motor 110V/220V DC/AC
- Key interlocking
- Auxiliary contacts
- Load switch position 2NO+2NC
- Secondary device can be installed in
  - Secondary line chamber at the top of the switchgear
  - Low voltage box at the top of the switchgear

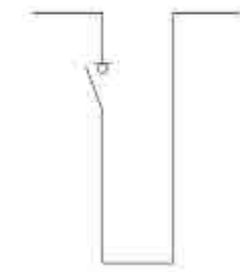

**YRM6-12~24 Gas-insulated Metal-enclosed Switchgear**



**Expansion module-12kV metering cabinet**

**Standard configuration and characteristics**

- 2pcs current transformers
- 2pcs voltage transformers
- Fuse for PT protection
- Low voltage components
- Voltmeter
- Ammeter
- W×H×D=695×1334×820mm
- W×H×D=695×1680×820mm(with instrument box)

**Optional configuration and characteristics**

- Zinc oxide arrester
- Capacitive voltage indicator indicating the switchgear is electrified
- Low voltage components
- 1pc active watt-hour meter
- 1pc reactive watt-hour meter

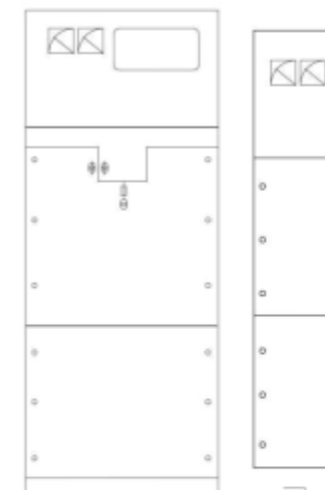
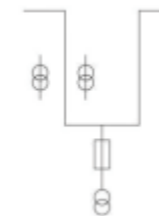

**Expansion module-12kV voltage transformer cabinet**

**Standard configuration and characteristics**

- 1pc or 2pcs voltage transformer
- Fuse for PT protection
- Voltmeter
- W×H×D=695×1334×820mm
- W×H×D=695×1680×820mm (with instrument box)

**Optional configuration and characteristics**

- Zinc oxide arrester (695 width)
- Capacitive voltage indicator indicating the switchgear is electrified

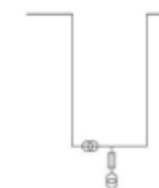

## Medium Voltage Switchgear YRM6-12~24 Gas-insulated Metal-enclosed Switchgear

### Incoming / outgoing line protection

- Use vacuum switch / vacuum circuit breaker module
- The transformer or line protection is a vacuum switch/vacuum circuit breaker, with protective relays and current transformers. When the fault current reaches the setting current set by the protection relay, the protection relay issues a command to trip the switch through the trip unit.)

### Transformer / line protection

The YRM6 provides two types of transformer protection: load switch fuse combination and circuit breaker with relay protection.

### Use load switch fuse combination module

Transformer protection is a combination of current limiting high voltage fuse and load switch. The fuse compartment will be mounted behind a separate, latched enclosure at the front of the unit. The load switch uses a spring charging mechanism that can be triggered by a fuse striker. To facilitate the replacement of the fuse, an operating handle can be used to remove the end cap of the fuse compartment. The trip mechanism of the fuse is placed in front to ensure the water proof performance of the entire system. The load switch fuse combination uses a spring-loaded type of backup-protection type current limiting fuse, and the striker side faces the front of the switchgear during installation.

### Fuse-transformer comparison table

100%	Rated capacity of power transformer (KVA)															
Un(kV)	25	50	75	100	125	160	200	250	315	400	500	630	800	1000	1250	1600
3	16	25	25	40	40	50	50	80	100	125	160	160				
3.3	16	25	25	40	40	50	50	63	80	100	125	160				
4.15	10	16	25	25	40	40	40	50	63	80	100	125	160			
5	10	16	25	25	25	40	40	50	50	63	80	100	160	160		
5.5	6	16	16	25	25	25	25	50	50	63	80	100	125	160		
6	6	16	16	25	25	25	25	40	50	50	80	100	125	160	160	
6.6	6	16	16	25	25	25	25	40	50	50	63	80	100	125	160	
10	6	10	10	16	16	25	25	25	40	40	50	50	80	80	125	125
11	6	6	10	16	16	25	25	25	25	40	50	50	63	80	100	125
12	6	6	10	16	16	16	16	25	25	40	40	50	63	80	100	125
13.8	6	6	10	10	16	16	16	25	25	25	40	50	50	63	80	100
15	6	6	10	10	16	16	16	25	25	25	40	40	50	63	80	100
17.5	6	6	6	10	10	16	16	16	25	25	25	40	50	50	63	80
20	6	6	6	10	10	16	16	16	25	25	25	40	40	50	63	63
22	6	6	6	6	10	10	10	16	16	25	25	25	40	50	50	63
24	6	6	6	6	10	10	10	16	16	25	25	25	40	40	50	63

## Medium Voltage Switchgear YRM6-12~24 Gas-insulated Metal-enclosed Switchgear

### Plan Instructions

#### Plan 1 CCF+

Incoming line installed lightning arrester and with reserved extension

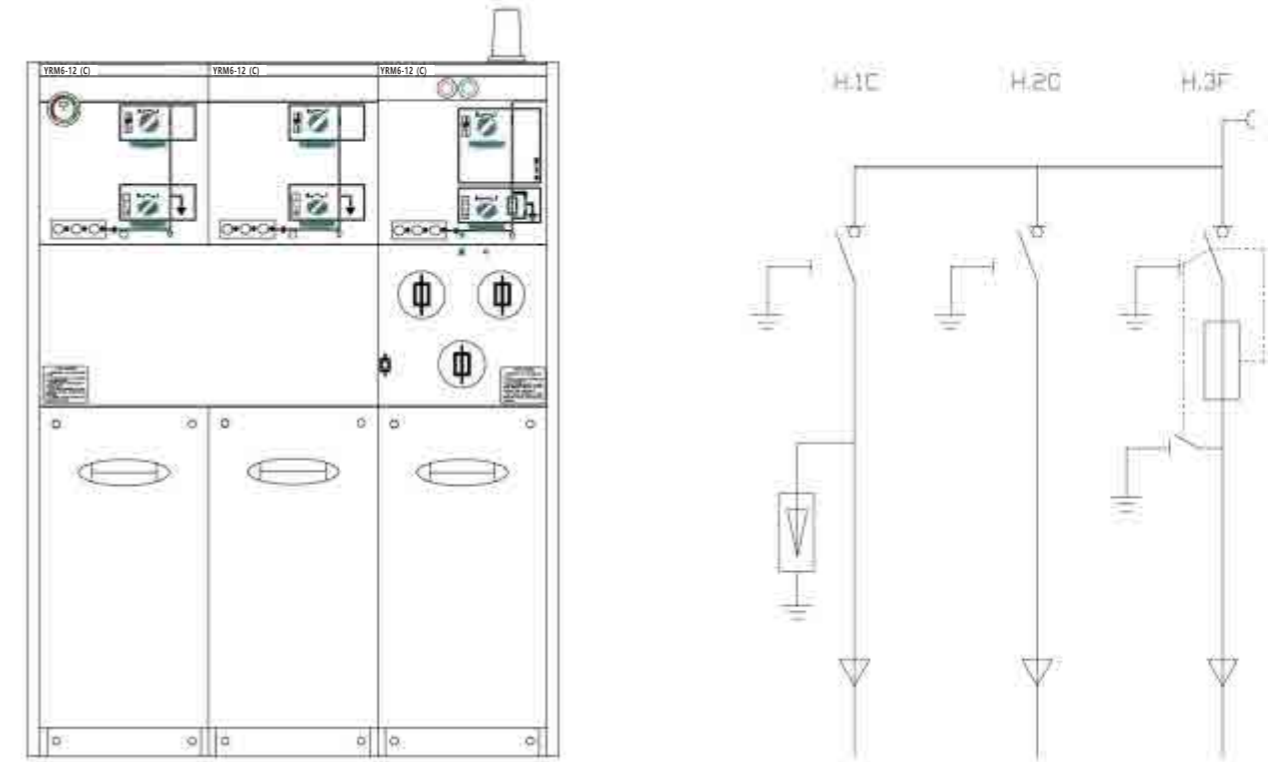

#### Plan 2 CCFF=CF

1 set at most 5 units, more than 5 units need to expand the bus connection

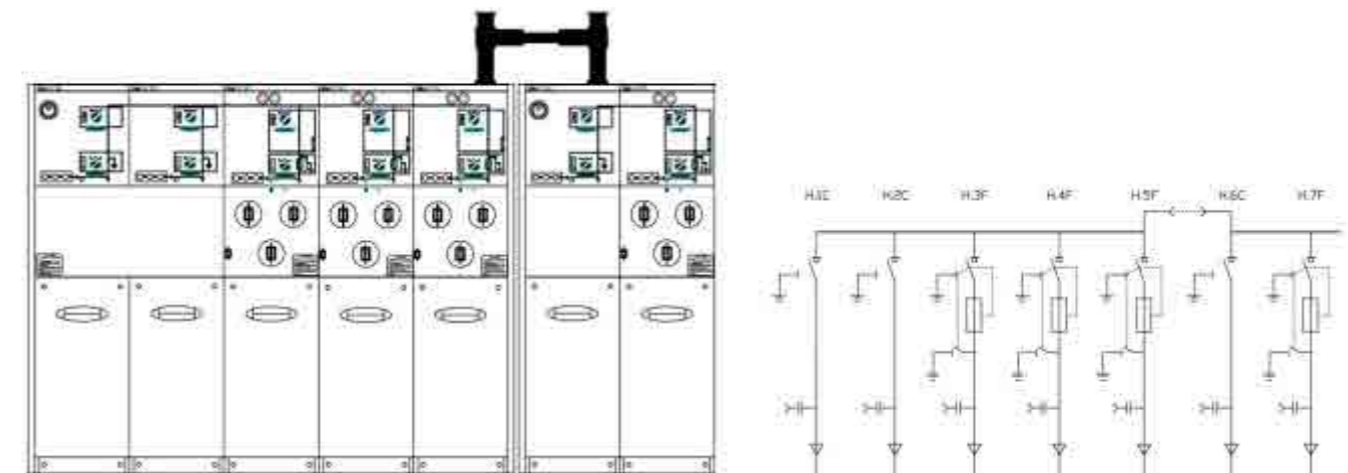

## Medium Voltage Switchgear YRM6-12~24 Gas-insulated Metal-enclosed Switchgear

### Plan 3 VV=M=FFF

High voltage side measurement

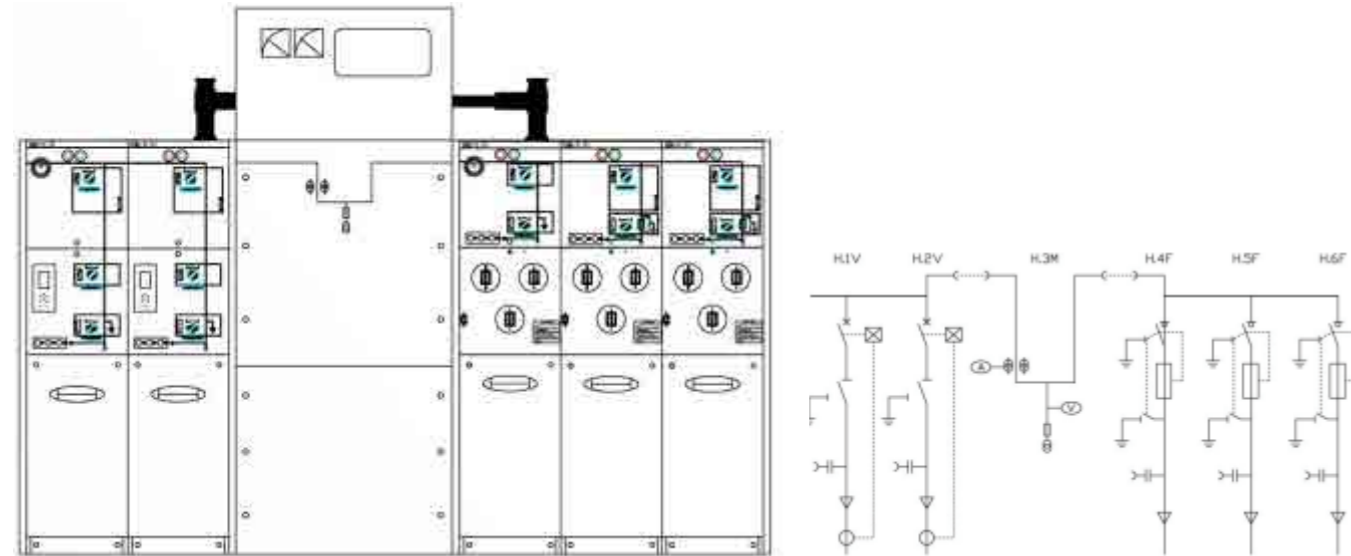

### Plan 4 PT=FF=FCSLCF=FF=PT

PT Single busbar section with busbar PT

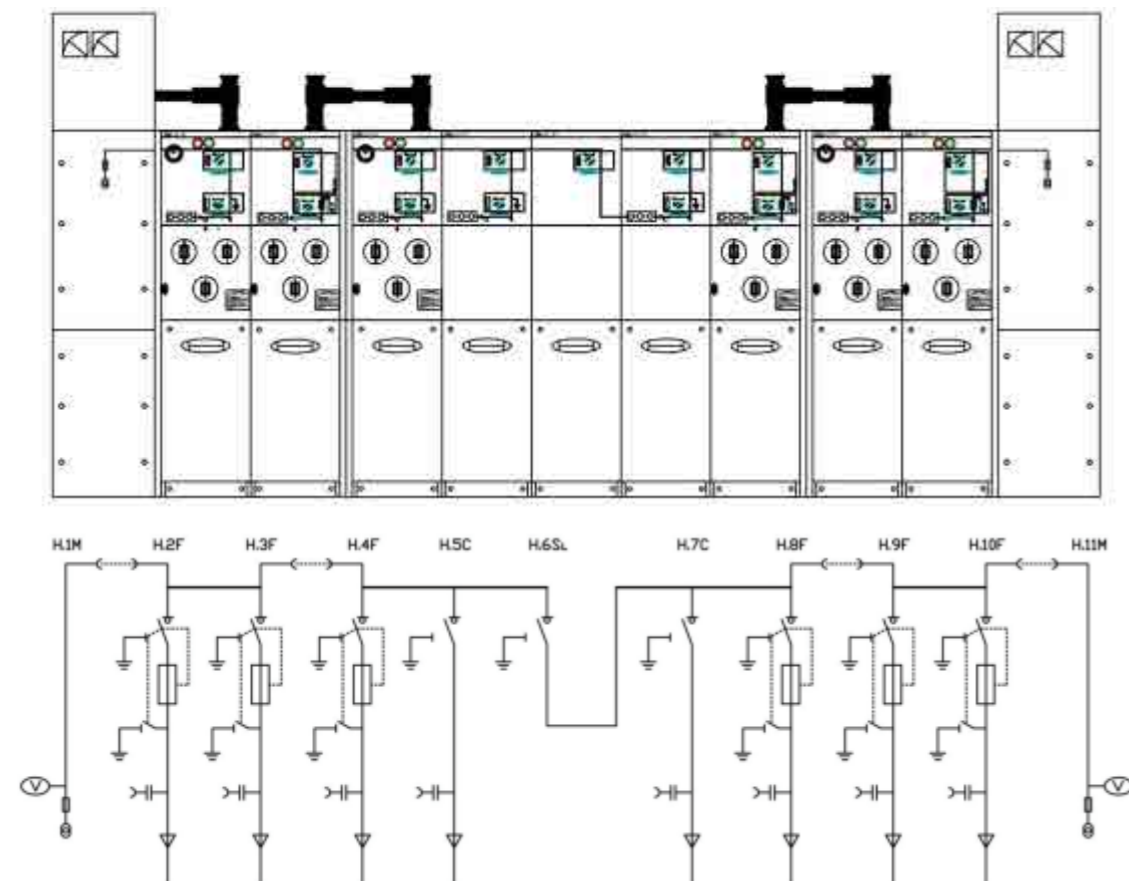

## Medium Voltage Switchgear YRM6-12~24 Gas-insulated Metal-enclosed Switchgear

### Annex

#### 1. Auxiliary contacts

2NO+2 NC indicator switch positions are available on all load switches and circuit breakers. A parallel trip coil(AC or DC) can be mounted to the transformer/switch breaker. The LV control unit is located behind the front panel.

#### 2. Voltage indication

A capacitive voltage indicator indicates whether the bushing is energized and the socket on it can be used for the nuclear phase.

#### 3. Short circuit / ground fault indicator

To facilitate fault location, the cable switch module can be equipped with a short circuit/ground fault indicator for simple fault detection.

#### 4. Electric operation

The manual operation of the cable switch unit and the transformer unit is a standard solution. It is also possible to install an electric operating mechanism. Cable switch, vacuum circuit breaker, and earth switch are operated by mechanism located behind the front panel. All switches and circuit breakers can be operated by operating the handle (standard configuration) or can be equipped with a motor operating mechanism (accessory). However, the earth switch can only be operated manually and is equipped with a mechanism that has the ability to close the fault current. Electric operating mechanisms are easy to implement in stages.

#### 5. Cable connection

The YRM6 switchgear is fitted with standard bushings. All bushings are the same height from the ground and are protected by a cable compartment cover. This cover can be interlocked with the earth switch. For dual cab incoming, a dedicated dual cable compartment cover can also be used.

#### 6. Pressure indicator

Usually equipped with a pressure indicator, this indicator is in the form of a pressure gauge. Electrical contacts can also be provided to indicate a pressure drop.

#### 7. External busbar

The YRM6 switchgear can be equipped with an external busbar with rated current 1250A.

#### 8. Secondary line chamber / low voltage box

The YRM6 switchgear can be equipped with a secondary line compartment or a low voltage box at the top of the switchgear.

The secondary line compartment is used to install an ammeter (with or without a changeover switch) and a live blocking control unit. The low voltage box is used to install relays such as SPAJ140C, REF, and can also be equipped with an ammeter (with or without changeover switch) and a live blocking control unit.

#### 9. Lightning arrester

The cable incoming/outgoing module of the YRM6 type switchgear can be equipped with a zinc oxide lightning arrester at the cable; a zinc oxide lightning arrester can also be installed on the busbar or in the M cabinet.

## Medium Voltage Switchgear YRM6-12~24 Gas-insulated Metal-enclosed Switchgear

### Switchgear structure diagram

1. Cable room
2. Fuse blow indicator
3. Fuse room
4. Installation room
5. charged display
6. Pressure indicator
7. Padlock device on the panel
8. Earth switch operating hole
9. Load switch operation hole
10. Analog circuit diagram
11. Opening button
12. Closing button
13. Circuit breaker operation hole
14. Disconnect switch operating hole foundation diagram

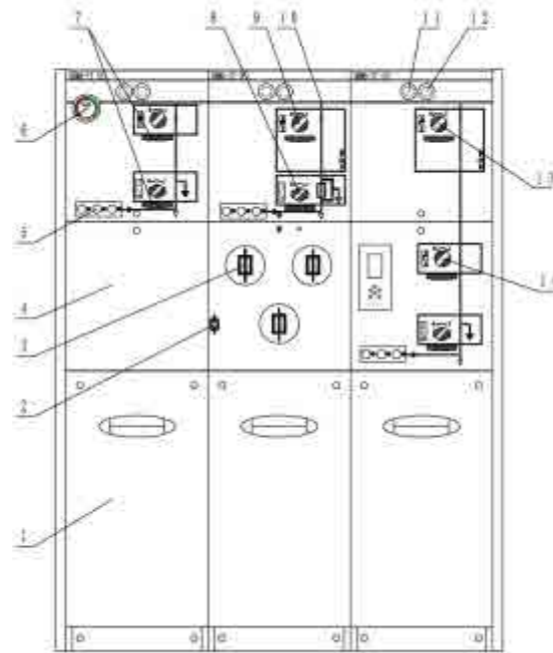

### Overall and mounting dimensions(mm)

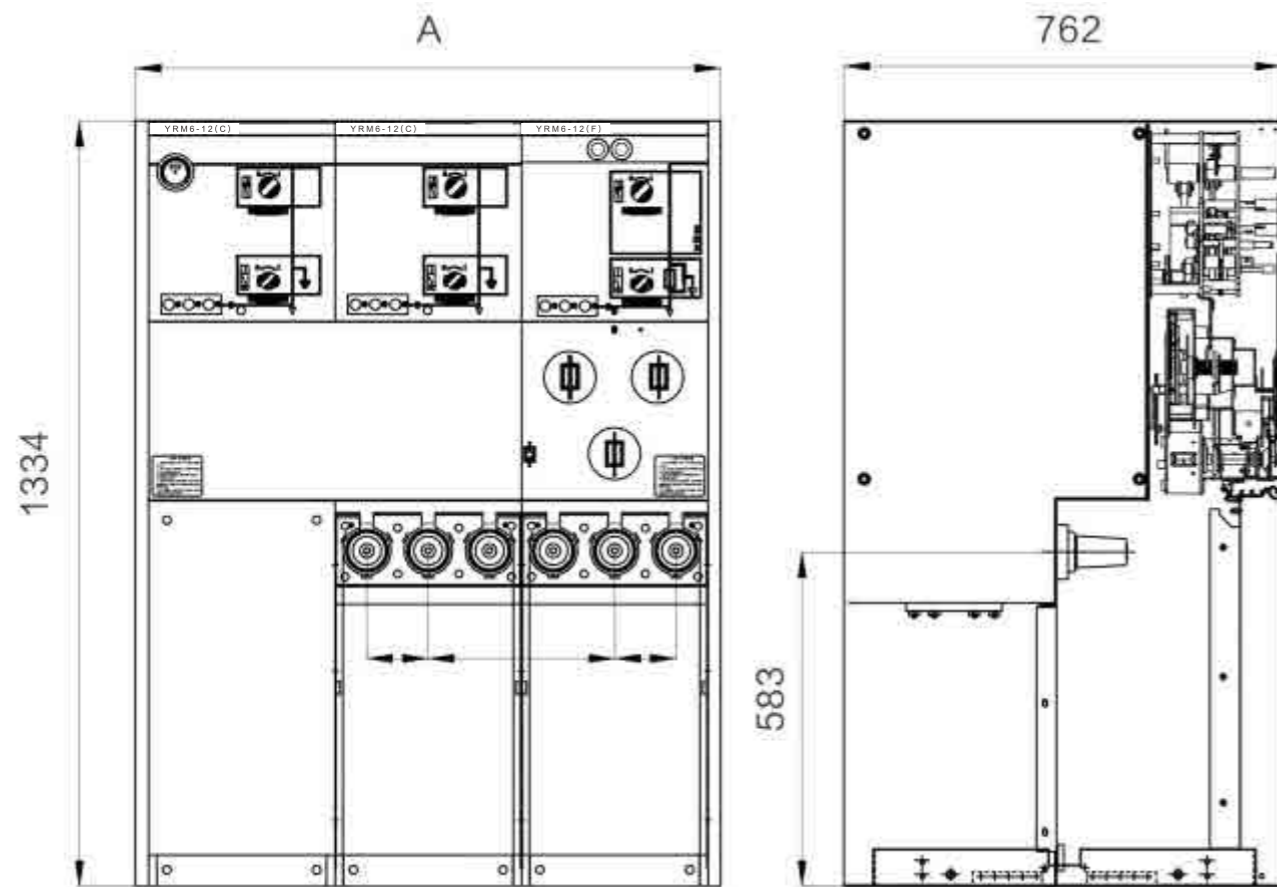

## Medium Voltage Switchgear YRM6-12~24 Gas-insulated Metal-enclosed Switchgear

### Foundation diagram

1. Standard unit

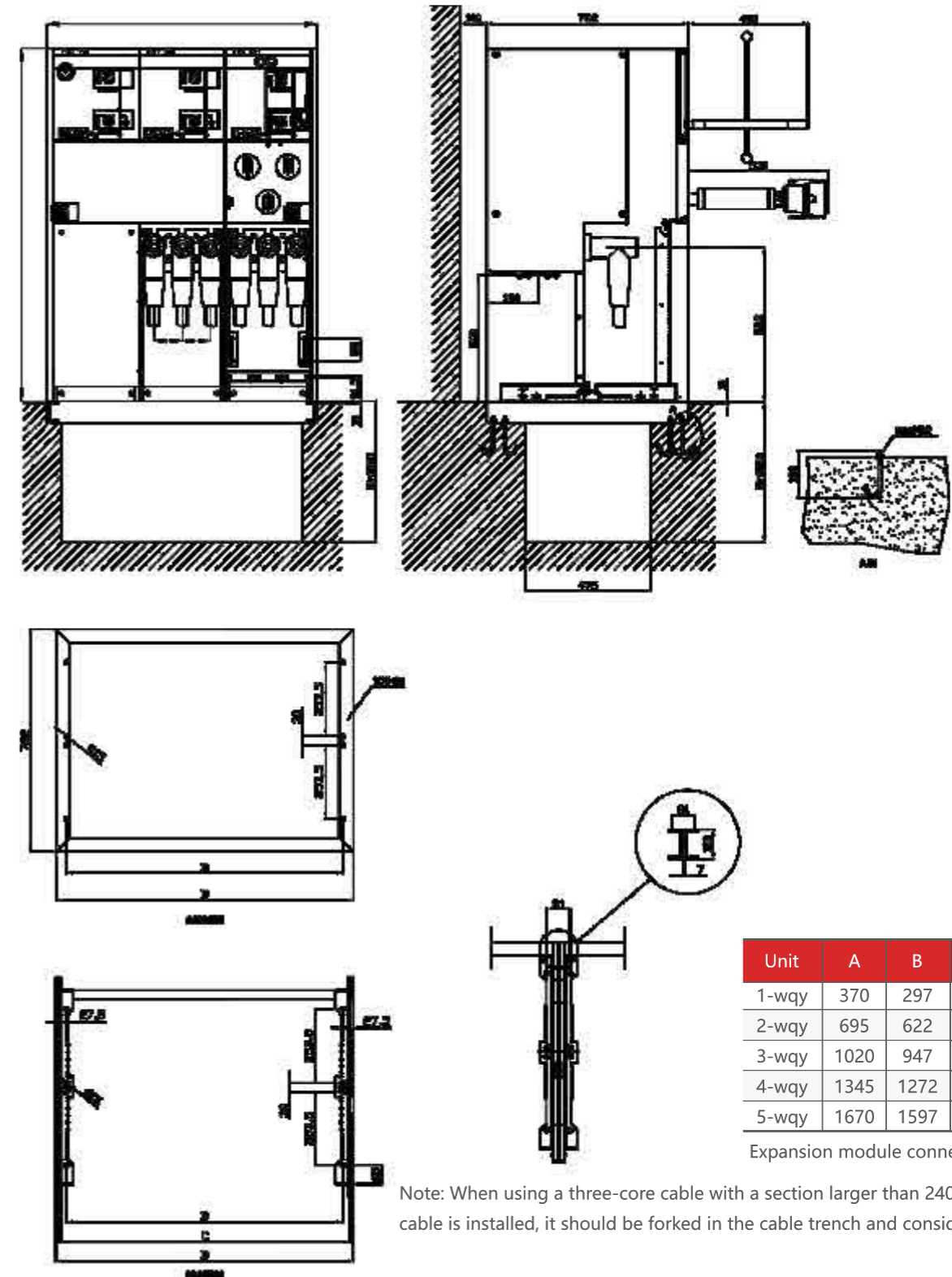

Unit	A	B	C	D
1-wqy	370	297	336	370
2-wqy	695	622	663	695
3-wqy	1020	947	988	1020
4-wqy	1345	1272	1313	1345
5-wqy	1670	1597	1636	1670

Expansion module connection diagram

Note: When using a three-core cable with a section larger than 240mm<sup>2</sup>, if the CT cable is installed, it should be forked in the cable trench and considered for fixing.

## Medium Voltage Switchgear YRM6-12~24 Gas-insulated Metal-enclosed Switchgear

### Foundation diagram

2. 10kV metering cabinet

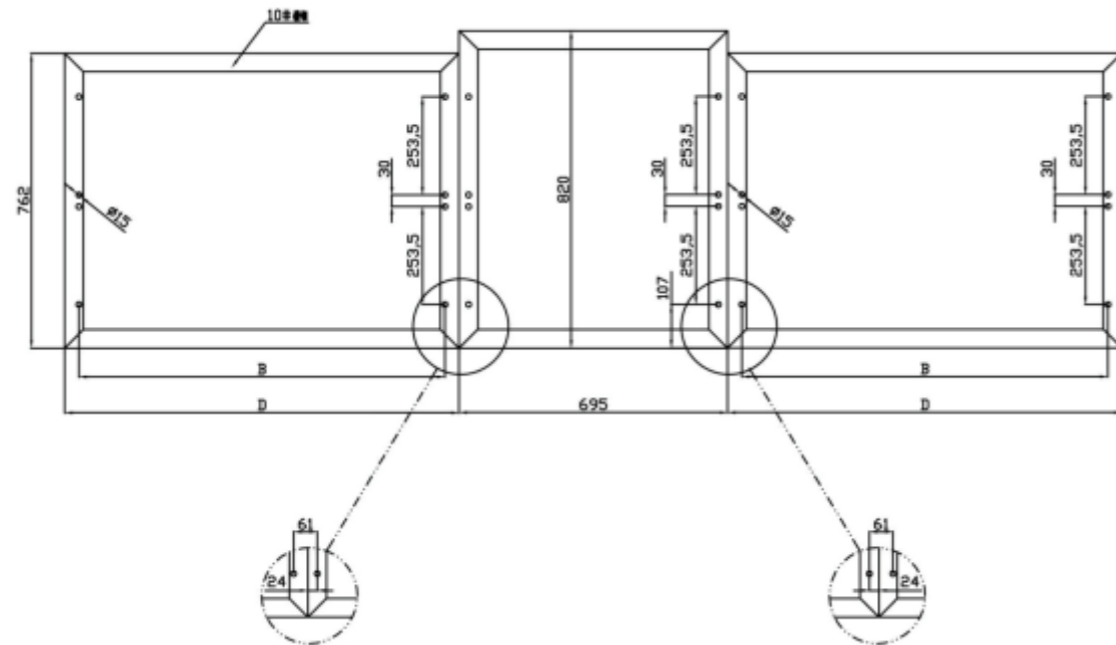

Top view of the base channel steel when the YRM6 cabinet is connected to the 10kV M cabinet or PT cabinet

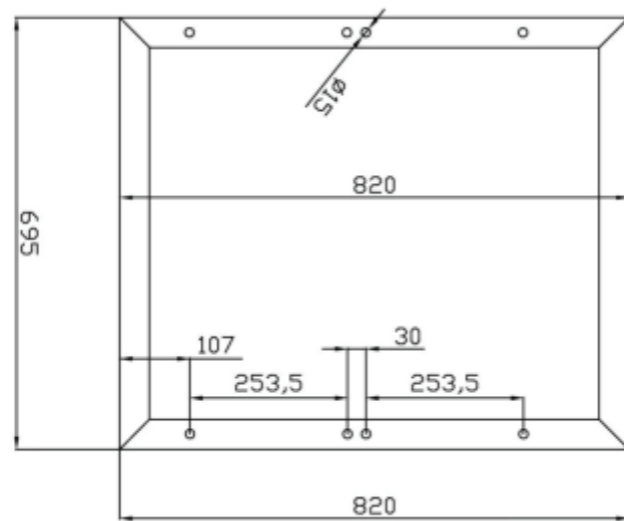

Foundation diagram of YRM6 cabinet connected to 10kV M cabinet or PT cabinet

### Ordering Instructions

When ordering, the following technical information must be provided :

- Main circuit diagram, arrangement diagram, and layout diagram
- Switchgear secondary circuit schematic diagram;

If the switchgear is used under special environmental conditions, it should be proposed.

## Medium Voltage Switchgear YRM6-12~24 Gas-insulated Metal-enclosed Switchgear

### Accessories and auxiliary components

Cable accessories: used for connecting switchgear and external circuits, while ensuring the safety and reliability of electrical insulation. It mainly includes two types of front and rear cable joints, as shown in the following figure:



Cable connector installation mode:



## Medium Voltage Switchgear

### YRM6-40.5 SF6 Gas Insulated Metal Enclosed Switchgear

- YRM6-40.5 series SF6 gas insulated metal enclosed switchgear is suitable for three-phase AC 50Hz, rated voltage 40.5kV power distribution system, for breaking and closing load current, overload current, closing and closing short circuit. Disconnect capacitive loads such as no-load transformers, overhead lines, cable lines and capacitor banks at a certain distance, and play the role of power distribution, control and protection in the power system.
- It is a multi-circuit ring network switchgear with safe operation and high reliability that can adapt to various harsh environmental conditions such as wet and salty fog, such as floods and heavy pollution. It is widely used in industrial parks, streets, airports, residential quarters, bustling commercial centers, etc.

#### General

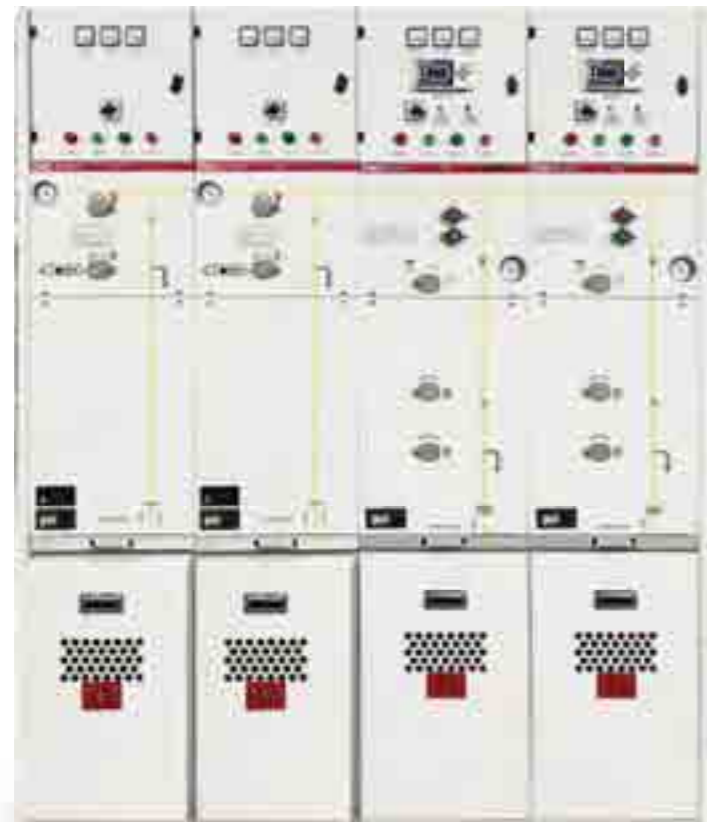

## Medium Voltage Switchgear

### YRM6-40.5 SF6 Gas Insulated Metal Enclosed Switchgear

#### Selection

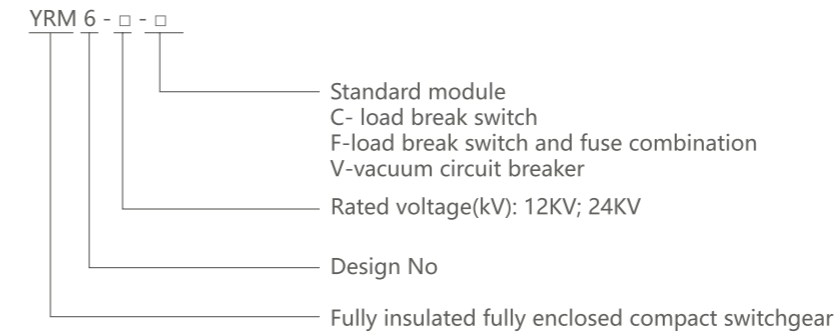

#### Operating conditions

- Ambient temperature: -40°C~+40°C (below -30°C should be negotiated by user and manufacturer).
- Altitude: ≤2500m (exceed 2500m should be negotiated by the user and the manufacturer).
- Earthquake intensity: ≤8 degrees.
- Maximum average relative humidity: 24h average ≤95%; monthly average ≤90%.
- Places free from fire, explosion, chemical corrosion and frequent violent vibration.

#### Features

##### • Fully enclosed and fully insulated design

All live parts of YRM6-40.5 are sealed in a box welded by 304 stainless steel plate, the box is filled with SF6 gas with a working pressure of 1.4bar, and the protection level is IP67. It is suitable for installation in areas with high humidity and dust pollution, especially suitable for mines, box-type substations and any places that are prone to surface flashover due to air pollution. The product is installed with a DIN47636 standard sleeve, and is connected to the cable through a fully insulated, fully sealed, shielded cable joint.

##### • High reliability and personal safety

All live parts are sealed in SF6 air chamber; the air chamber has a reliable pressure relief channel, which has passed the 20kA/0.5s internal fault arc test: the load switch and grounding switch are three-position switches, which simplifies the interlocking between them. There is a reliable mechanical interlock between the cable compartment cover and the load switch, which can effectively prevent entering the live interval by mistake.

##### • Product maintenance free

Maintenance-free and long life cycle The product is designed with a life cycle of 30 years. During the product life cycle, the main switch does not require maintenance. The annual leakage rate of the product is <0.1%.

##### • Compact structure

Except for the air-insulated metering cabinet and PT cabinet, all modules are only 350mm wide, and the cable connection bushings of all units have the same height to the ground, which is convenient for on-site construction.

# Medium Voltage Switchgear YRM6-40.5 SF6 Gas Insulated Metal Enclosed Switchgear

## Technical data

NO.	Items	Unit	C module		400/415V		V module	
			Load switch	Combination	Vacuum switch	Disconnect/earth switch		
1	Rated voltage	kV	40.5					
2	Power frequency withstand voltage	kV	95/118					
3	Lightning impulse withstand voltage	kV	185/215					
4	Rated current	A	630	80*	630	1250	630	
5	Closed-loop breaking current	A	630	/	/	/	/	
6	Cable charging breaking current	A	10	/	/	/	/	
7	5% rated active load breaking current	A	31.5	/	/	/	/	
8	Ground fault breaking current	A	31.5	/	/	/	/	
9	Rated short circuit breaking current	kA	/	Note 2	20	25	/	
10	Rated short circuit making current	kA	63	Note 2	50	63	50/40	
11	Rated short time withstand current 2S	kA	20	/	20	25	/	
12	Rated short circuit duration	/	4	/	/	/	/	
13	Mechanical life	times	5000	5000	10000	5000		
14	SF6 gas pressure	1.4bar(20°C)						
15	SF6 annual leakage rate	0.1%						
16	Protection class	IP67/4X(gas box/enclosure)						

Note: means depends on or limited by the fuse.

## Overall and mounting dimensions(mm)

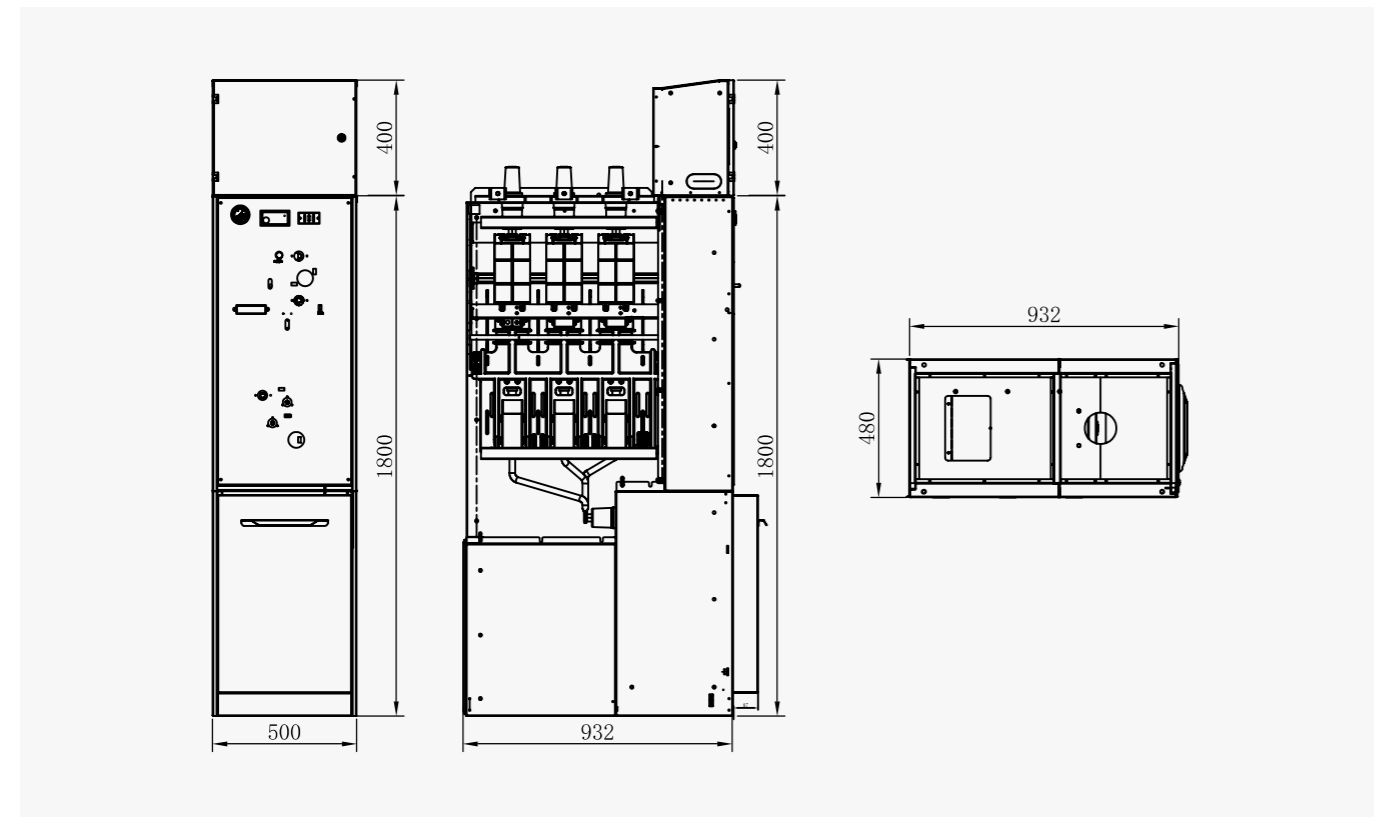

Picture 1

# Medium Voltage Switchgear YRM6-40.5 SF6 Gas Insulated Metal Enclosed Switchgear

## Main primary line scheme

01	02	03	04	05	06	07
Cable entry (output)	Cable entry (output)	Cable entry (output)	Cable entry (output)	Cable entry (output)	Cable entry (output)	Cable entry (output)
08	09	10	11	12	13	14
Cable entry (output)	Cable entry (output)	Cable entry (output)	Cable entry (output)	Cable entry (output)	Cable entry (output)	Cable entry (output)
15	16	17	18	19	20	21
Cable entry (output)	Cable entry (output)	Measurement	Measurement	PT cabinet	PT cabinet	PT cabinet
22	23	24	25	26	27	28
PT cabinet	Contact left and right	Contact left and right	Contact left and right	Contact left and right	Contact left and right	Contact left and right
29	30					
Busbar contact	Busbar contact					



## Medium Voltage Switchgear

### YGH-12 Environmentally Friendly Gas-insulated Ring Main Unit



#### General

The YGH-12 environmentally friendly gas-insulated ring main unit (RMU) is designed for a voltage of 12kV, three-phase AC 50/60Hz, and is a complete distribution device for single busbar and single busbar sectionalized systems. This RMU utilizes dry air or nitrogen as the insulating medium and features strong environmental adaptability, compact size, safe and reliable operation, maintenance-free operation, and intelligent capabilities. It is widely used in industrial and civil cable ring networks and distribution network terminal projects for receiving and distributing electrical energy. It is commonly employed in urban residential areas, small-scale substations, commercial areas, industrial and mining enterprises, public buildings, infrastructure, and other locations. Standards: IEC 60694; IEC 62271-200; IEC 62271-102; IEC 62271-103; IEC671; IEC60529.

#### Selection

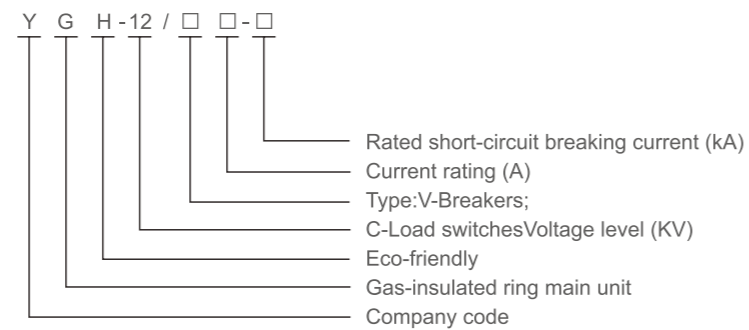

#### Operating Conditions

1. Temperature: -25~+45°C;
2. Maximum temperature: (24h average) +35°C;
3. Average relative humidity (24h): ≤95%;
4. Altitude: ≤1500m;
5. Seismic ability: 8 degrees;
6. Protection degree: IP67 for live body sealing, IP4X for switchgear enclosure;
7. The surrounding air should not be obviously polluted by corrosive flammable gas, water vapor, etc.;
8. Places without frequent violent vibration, and the severity design meets various requirements under severe conditions;

#### Features

1. Environmental protection, Wide range of application
2. Easy to operate, Maintenance-free, High security
3. Clearly visible real isolation break
4. Single cabinet structure, field-configurable, and expandable as desired
5. Replace SF6 load switch ring main unit

## Medium Voltage Switchgear

### YGH-12 Environmentally Friendly Gas-insulated Ring Main Unit

#### Technical data

Circuit Breaker Switchgear			
Items		Unit	Values
Rated voltage		kV	12
Rated frequency		Hz	50
Rated insulation level	1min power frequency withstand voltage	To earth, phase-to-phase	42
		Across isolating distance	48
	Lightning impulse withstand voltage (peak)	To earth, phase-to-phase	75
		Across isolating distance	85
Auxiliary/control circuit 1min power frequency withstand voltage (to earth)			2
Rated current		A	630
Rated short time withstand current (RMS)	Main circuit/earth switch	kA	25/4s
	Grounding connection circuit		21.7/4s
Rated short time withstand current (peak)	Main circuit/earth switch		63
	Grounding connection circuit		54.5
Rated short circuit breaking current and number		kA/ times	25/30
Rated short circuit making current (peak)		kA	63
Rated cable charging breaking current		A	25
Rated operating of circuit breaker			O-0.3s-CO-180s-CO
Mechanical life	Circuit breaker/disconnector	times	10000/3000
Protection degree	Sealed gas tank		IP67
	Switchgear enclosure		IP4X
Gas pressure	Gas rated fill level (20°C, gauge pressure)	Mpa	0.02
	Gas min. fill level (20°C, gauge pressure)		0
Sealing performance	Annual leakage rate	%/year	≤0.05

## Medium Voltage Switchgear

### YGH-12 Environmentally Friendly Gas-insulated Ring Main Unit

#### Technical data

Load Switch Switchgear			
Items		Unit	Values
Rated voltage		kV	12
Rated frequency		Hz	50
Rated insulation level	1min power frequency withstand voltage	To earth, phase-to-phase	42
		Across isolating distance	48
	Lightning impulse withstand voltage (peak)	To earth, phase-to-phase	75
		Across isolating distance	85
Auxiliary/control circuit 1min power frequency withstand voltage (to earth)			2
Rated current		A	630
Rated short time withstand current (RMS)	Main circuit/earth switch	kA	25/4s
	Grounding connection circuit		21.7/4s
Rated short time withstand current (peak)	Main circuit/earth switch	kA	63
Rated short circuit making current (peak)	Load switch/earth switch	kA	54.5
		kA	63
Rated active load breaking current		A	630
Rated closed loop breaking current		A	630
5% rated active load breaking current		A	31.5
Rated cable charging breaking current		A	10
Rated active load breaking number		A	100
Grounding fault current breaking		A/times	31.5/10
Circuit and cable charging current breaking under grounding fault condition		A/times	17.4/10
Mechanical life	Load switch/earth switch	times	10000/3000
Protection degree	Sealed gas tank		IP67
Gas pressure	Switchgear enclosure		IP4X
	Gas rated fill level (20°C, gauge pressure)	Mpa	0.02
	Gas min. fill level (20°C, gauge pressure)		0
Sealing performance	Annual leakage rate	%/year	≤0.05

## Medium Voltage Switchgear

### YGH-12 Environmentally Friendly Gas-insulated Ring Main Unit

#### Product structure

Overall structure

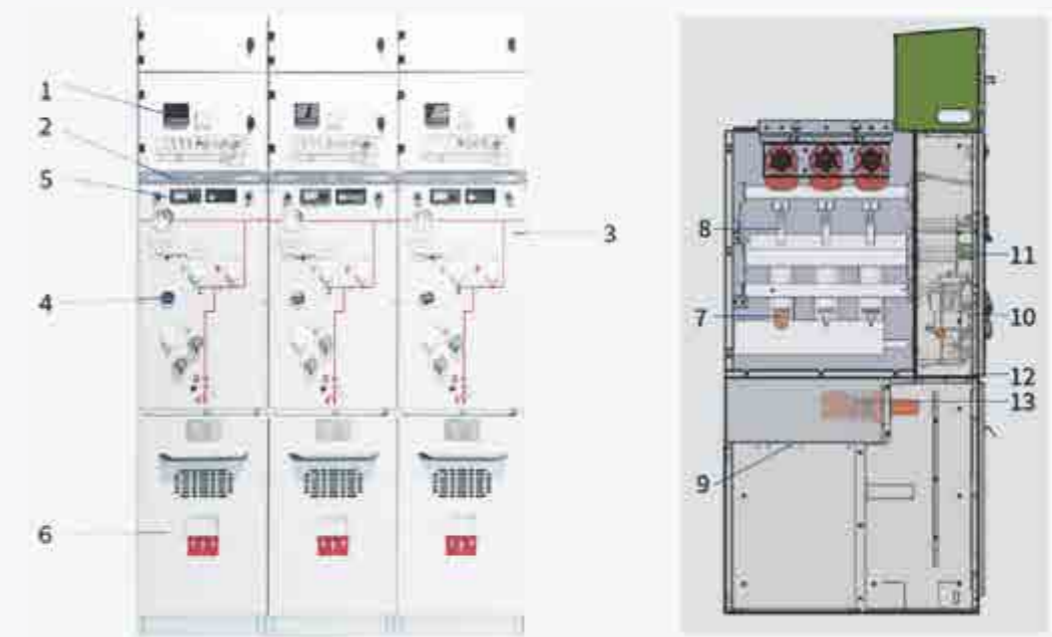

- 1.Low voltage instrument room
- 2.Brow
- 3.Control room
- 4.Observation tube
- 5.Live display monitor
- 6.Cable room
- 7.Vacuum circuit breaker/load switch
- 9.Pressure relief device
- 11.Three-position mechanism
- 13.Cable penetration wall sleeve

- 8.Three-position isolation/grounding switch
- 10.Switching mechanism
- 12.Five-protection interlock mechanism

## Medium Voltage Switchgear

### YGH-12 Environmentally Friendly Gas-insulated Ring Main Unit

#### Configurations

##### Standard Module - Vacuum Circuit Breaker Unit V

###### ■Standard Configuration and Features:

- ◆630A busbar
- ◆Vacuum circuit breaker
- ◆Motorized operating mechanism for vacuum switch
- ◆Three-position isolation switch
- ◆Manual operating mechanism for three-position isolation switch
- ◆Position indicators for vacuum switch and three-position isolation switch
- ◆Cable connection sleeve
- ◆Capacitive voltage indicator with live display sleeve
- ◆Pressure gauge
- ◆Locking device
- ◆Cabinet
- ◆Ground busbar
- ◆Operating handle
- ◆Current transformer (for protection only)
- ◆Digital relay protection device

###### ■Optional Configuration and Features:

- ◇Short circuit and ground fault indicators
- ◇Detachable connector (cable connector)
- ◇Lightning arrester
- ◇Incoming line live/ground locking device
- ◇Key mechanical interlocking device
- ◇Toroidal current transformer and meter

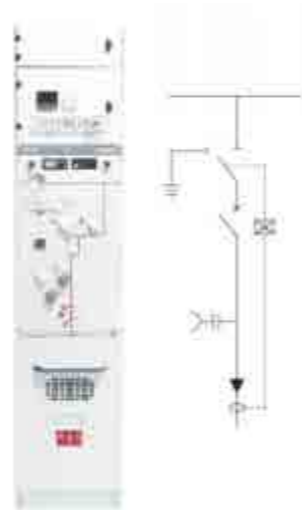

##### Standard Module - Load Switch Unit C

###### ■Standard Configuration and Features:

- ◆630A busbar
- ◆Vacuum load switch
- ◆Manual operating mechanism for vacuum load switch
- ◆Three-position isolation switch
- ◆Manual operating mechanism for three-position isolation switch
- ◆Position indicators for load switch and three-position isolation switch
- ◆Cable connection sleeve
- ◆Capacitive voltage indicator with live display sleeve
- ◆Pressure gauge
- ◆Locking device
- ◆Cabinet
- ◆Ground busbar
- ◆Operating handle

###### ■Optional Configuration and Features:

- ◇Electric operating mechanism for vacuum load switch
- ◇Short circuit and ground fault indicators
- ◇Detachable connector (cable connector)
- ◇Lightning arrester
- ◇Incoming line live/ground locking device
- ◇Key mechanical interlocking device
- ◇Toroidal current transformer and meter

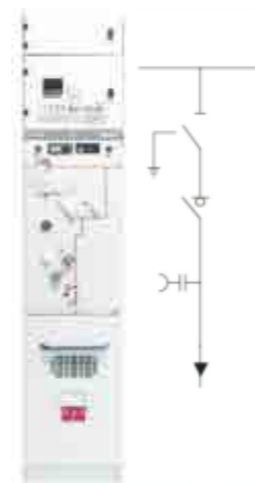

## Medium Voltage Switchgear

### YGH-12 Environmentally Friendly Gas-insulated Ring Main Unit

##### Standard Module - Voltage Transformer Unit PT

###### ■Standard Configuration and Features:

- ◆2 current transformers
- ◆Fuses to protect PT
- ◆1 voltmeter with transfer switch
- ◆Capacitive voltage indicator with live display sleeve
- ◆Cabinet
- ◆Pressure gauge

###### ■Optional Configuration and Features:

- ◇3 voltage transformers
- ◇Lightning arrester
- ◇Three-position isolation switch
- ◇Manual operating mechanism for three-position isolation switch



##### Standard Module - Metering Module M

###### ■Standard Configuration and Features:

- ◆630A busbar
- ◆2 voltage transformers
- ◆2 current transformers
- ◆Fuses to protect PT
- ◆Capacitive voltage indicator with live display sleeve
- ◆Cabinet

###### ■Optional Configuration and Features:

- ◇1 transfer switch
- ◇1 voltmeter
- ◇1/2/3 ammeters
- ◇1 active energy meter
- ◇1 reactive energy meter

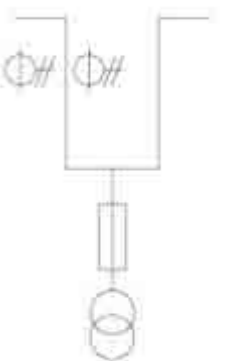

## Medium Voltage Switchgear

### YGH-12 Environmentally Friendly Gas-insulated Ring Main Unit

#### Configurations

##### Standard Module - Vacuum Circuit Breaker Unit V

###### ■Standard Configuration and Features:

- ◆630A busbar
- ◆Vacuum circuit breaker
- ◆Motorized operating mechanism for vacuum switch
- ◆Three-position isolation switch
- ◆Manual operating mechanism for three-position isolation switch
- ◆Position indicators for vacuum switch and three-position isolation switch
- ◆Cable connection sleeve
- ◆Capacitive voltage indicator with live display sleeve
- ◆Pressure gauge
- ◆Locking device
- ◆Cabinet
- ◆Ground busbar
- ◆Operating handle
- ◆Current transformer (for protection only)
- ◆Digital relay protection device

###### ■Optional Configuration and Features:

- ◇Short circuit and ground fault indicators
- ◇Detachable connector (cable connector)
- ◇Lightning arrester
- ◇Incoming line live/ground locking device
- ◇Key mechanical interlocking device
- ◇Toroidal current transformer and meter

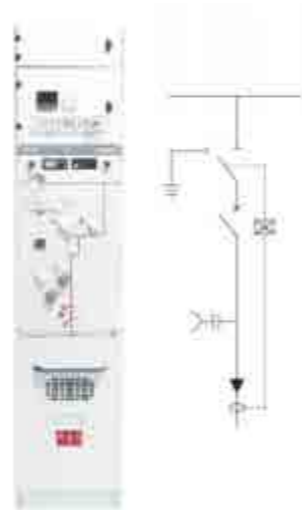

##### Standard Module - Load Switch Unit C

###### ■Standard Configuration and Features:

- ◆630A busbar
- ◆Vacuum load switch
- ◆Manual operating mechanism for vacuum load switch
- ◆Three-position isolation switch
- ◆Manual operating mechanism for three-position isolation switch
- ◆Position indicators for load switch and three-position isolation switch
- ◆Cable connection sleeve
- ◆Capacitive voltage indicator with live display sleeve
- ◆Pressure gauge
- ◆Locking device
- ◆Cabinet
- ◆Ground busbar
- ◆Operating handle

###### ■Optional Configuration and Features:

- ◇Electric operating mechanism for vacuum load switch
- ◇Short circuit and ground fault indicators
- ◇Detachable connector (cable connector)
- ◇Lightning arrester
- ◇Incoming line live/ground locking device
- ◇Key mechanical interlocking device
- ◇Toroidal current transformer and meter

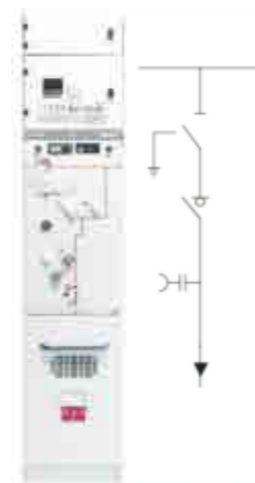

## Medium Voltage Switchgear

### YGH-12 Environmentally Friendly Gas-insulated Ring Main Unit

##### Standard Module - Voltage Transformer Unit PT

###### ■Standard Configuration and Features:

- ◆2 current transformers
- ◆Fuses to protect PT
- ◆1 voltmeter with transfer switch
- ◆Capacitive voltage indicator with live display sleeve
- ◆Cabinet
- ◆Pressure gauge

###### ■Optional Configuration and Features:

- ◇3 voltage transformers
- ◇Lightning arrester
- ◇Three-position isolation switch
- ◇Manual operating mechanism for three-position isolation switch



##### Standard Module - Metering Module M

###### ■Standard Configuration and Features:

- ◆630A busbar
- ◆2 voltage transformers
- ◆2 current transformers
- ◆Fuses to protect PT
- ◆Capacitive voltage indicator with live display sleeve
- ◆Cabinet

###### ■Optional Configuration and Features:

- ◇1 transfer switch
- ◇1 voltmeter
- ◇1/2/3 ammeters
- ◇1 active energy meter
- ◇1 reactive energy meter

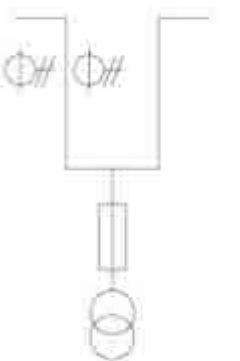

## Medium Voltage Switchgear

### YGH-12 Environmentally Friendly Gas-insulated Ring Main Unit

#### Typical plan combination

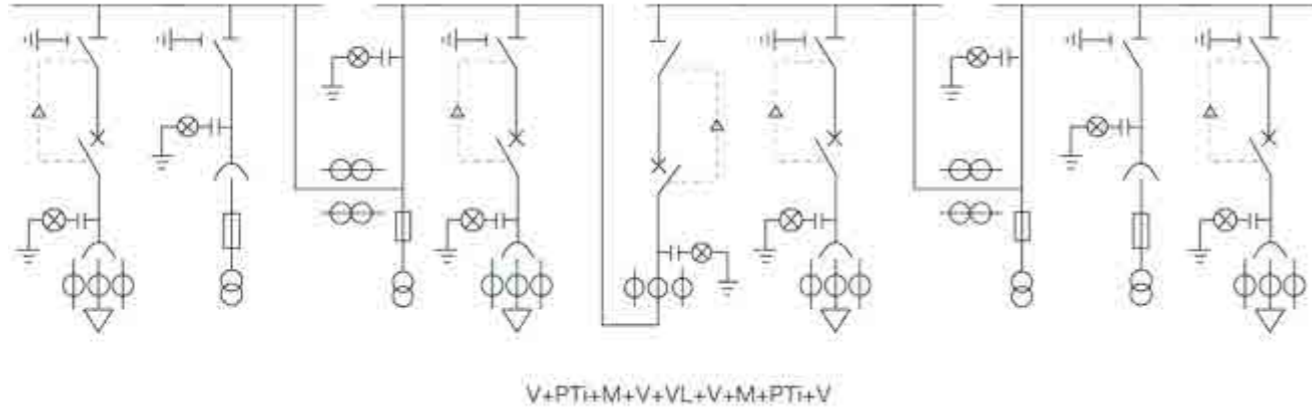

Note: The above typical combination reference scheme can be combined according to user needs.

#### Installation instructions

Foundation and overall dimensions(mm)  
This product should be installed on the pre-buried channel steel of the concrete platform, and the platform should be enough to bear the total weight of the equipment.

Note:  
The basic channel steel for secondary pouring is reversed, and the roughness is not more than 1mm. The switchgear is fixed on the basic channel steel.  
The basic load of the welding switchgear is 500-700kg/unit.

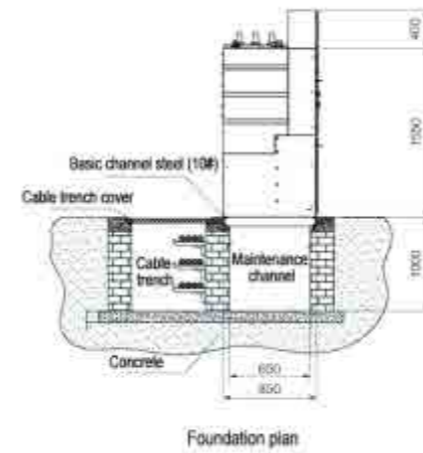

#### Switchgear and installation dimensions(mm)

Switchgear height 1550mm  
(without independent instrument room)  
If need an independent instrument room,  
the switchgear height is 1950mm.  
Standard configuration cabinet depth is 850mm.

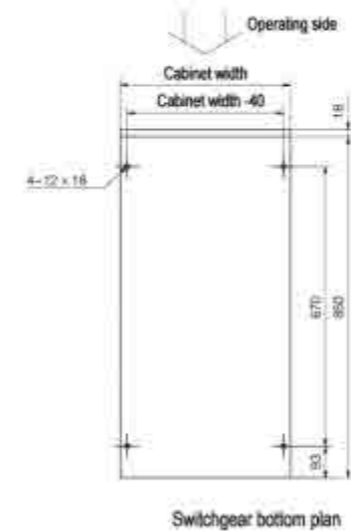

## Low Voltage Switchgear



**CNC**  
ELECTRIC

## Low Voltage Switchgear **GGD** Low Voltage Power Distribution Cabinet

- Rating: Rated voltage: 380V.
- 50-60Hz
- Application:  
mainly applicable in power station, power substation industrial and mining enterprises as energy converter, distributor and controller of power, light and distribution device.
- Standard: IEC60439-1

### General

## Low Voltage Switchgear **GGD** Low Voltage Power Distribution Cabinet

### Selection

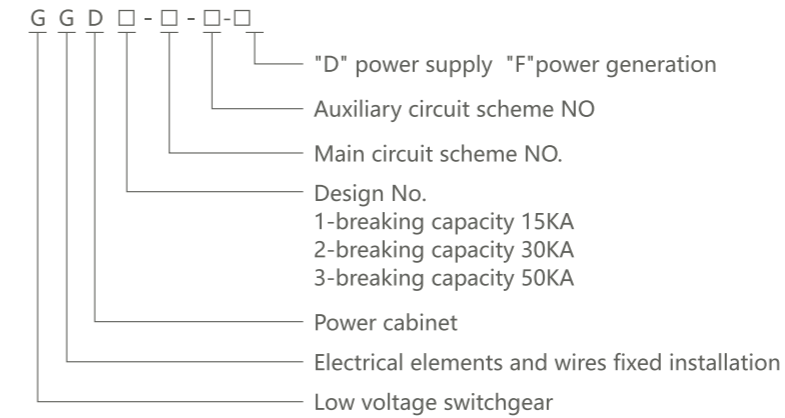

### Operating conditions

- Ambient air temperature:  $-15^{\circ}\text{C}\sim+40^{\circ}\text{C}$   
Daily average temperature:  $\leq 35^{\circ}\text{C}$   
When the actual temperature exceed the range, it should be used by reducing the capacity accordingly.
- Transport and store temperature:  $-25^{\circ}\text{C}\sim+55^{\circ}\text{C}$ . do not exceed  $+70^{\circ}\text{C}$  in short time.
- Altitude:  $\leq 2000\text{m}$
- Relative humidity:  $\leq 50\%$ , when temperature is  $+40^{\circ}\text{C}$   
When temperature is low, larger relative humidity is allowed. when it is  $+20^{\circ}\text{C}$ , relative humidity can be 90%. Since the temperature change will make out condensation.
- Installation inclination:  $\leq 5\%$
- Applicable in the places without corrosive and flammable gas.

Note: Customized products are available.



**Technical data**

1. Main technical data

Sheet 1

Type	Rated voltage (V)	Rated current (A)	Rated short-circuit breaking current (kA)	Rated short-circuit withstand current (1s)(1kA)	Rated peak withstand voltage (kA)
GGD1	380	A 1000	15	15	30
	380	B 600(630)	15	15	30
	380	C 400	15	15	30
GGD2	380	A 1500(1600)	30	30	63
	380	B 1000	30	30	63
GGD3	380	A 3150	50	50	105
	380	B 2500	50	50	105
	380	C 2000	50	50	105

2. Main bus

- 1) Single copper busbar adopted when the rated current  $\leq 1500A$
- 2) Double copper busbar adopted when the rated current  $> 1600A$ .
- 3) Brushing & anodizing process adopted which is better than traditional zinc-coated process.

3. Selection of horizontal bus

Sheet 2

Rated current (A)	Copper Busbar specification (mm)
400	40×4
630	50×5
1250	60×10
1600	80×10
2000	2×(60×10)
2500	2×(80×10)
3150	2×(100×10)

4. Selection of neutral earthin bus

Sheet 3

Cross section of phase conductor (mm <sup>2</sup> )	Cross section of PE(N) conductor (mm <sup>2</sup> )
500~720	40×5
1200	60×6
>1200	60×10

**Features**

1. The accuracy and quality of the switchgear could be ensured as the framework parts and special parts supplied by CNC. Modular design of the Overall and mounting dimensions(mm) s concerning(E=20mm), which has cut production time and enhanced efficiency.
2. The heat dispensation channel at the top and bottom of the switchgear formulate a ventilation loop to dispense the heat.
3. Easy for installation and dismantling.
4. The switchgear with perfect earthing protection system.
5. The cover of the switchgear could be removed for installation and adjustment of the main bus bar. there are also rings for lifting and delivery of switchgear
6. The protection degree is IP30,As per you requirements,switchgears with protection degree of IP20~IP40 are available.
7. Flexible circuit plans are available.

**Overall and mounting dimensions(mm)**

Picture 1

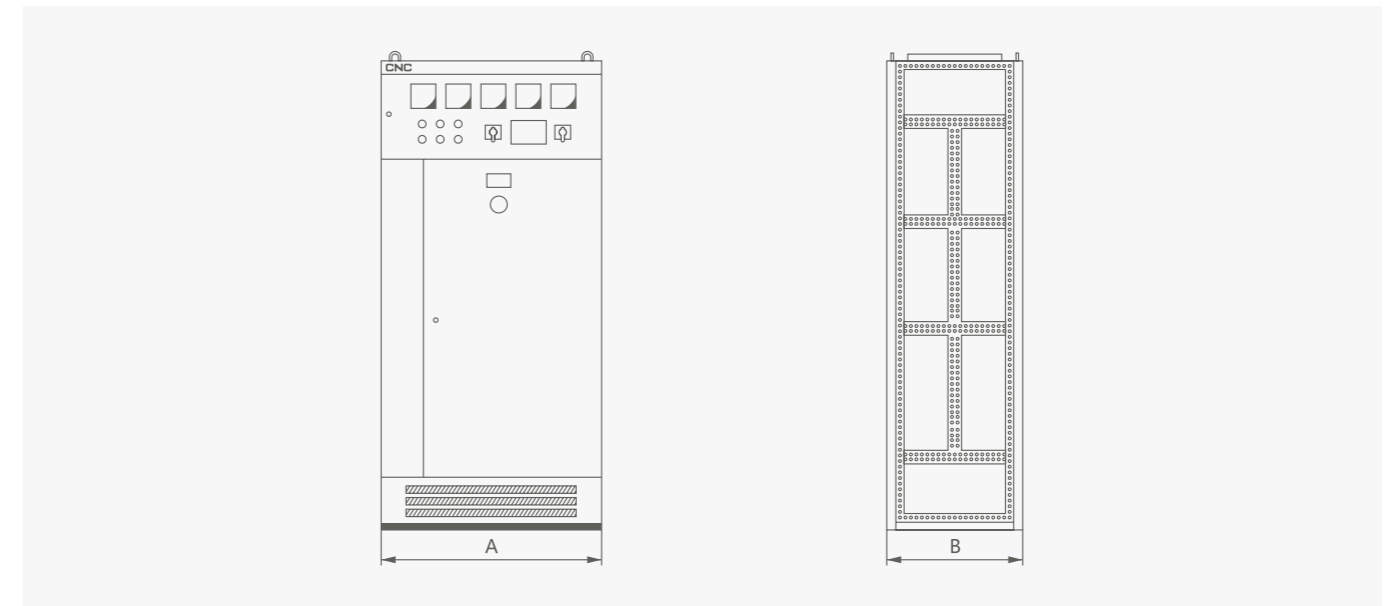

Product code	A	B
GGD 06	600	600
GGD 06A	600	800
GGD 08	800	600
GGD 08A	800	800
GGD 10	1000	600
GGD 10A	1000	800
GGD 12	1200	800

# Low Voltage Switchgear

## GGD Low Voltage Power Distribution Cabinet

Installation Overall and mounting dimensions(mm)

Picture 2

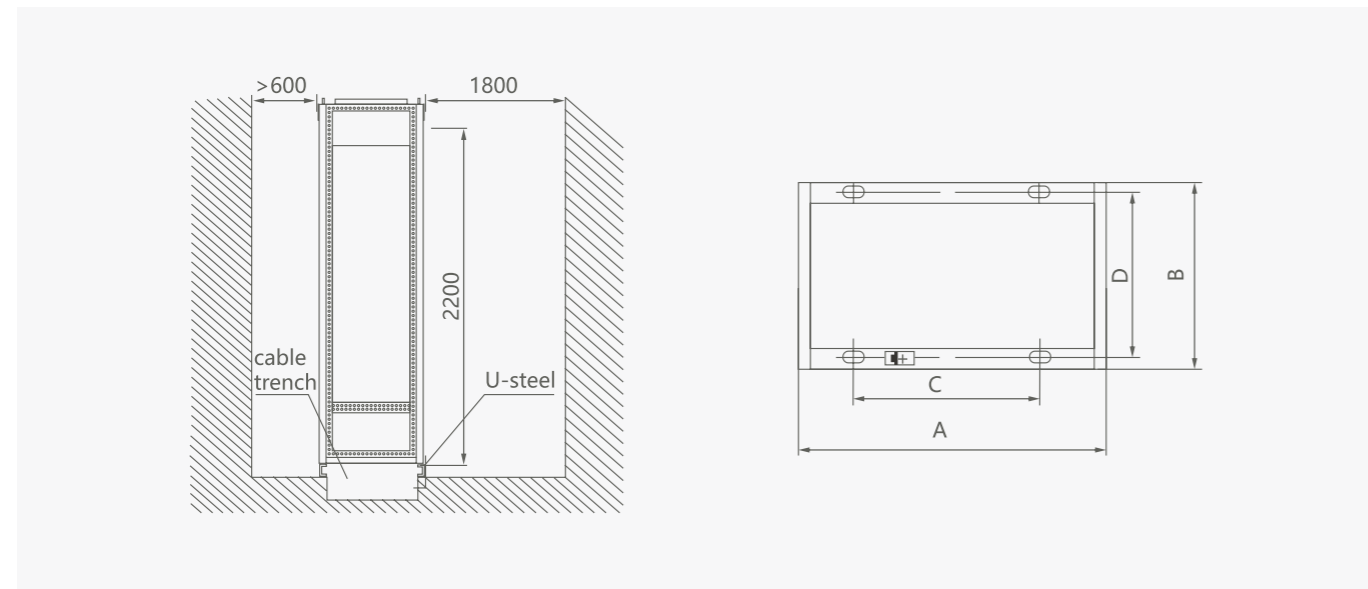

### Low Voltage Switchgear

#### GCS Low-voltage Switchgear Panel, Withdrawable Type

- Rating: Rated voltage 400V, 690V, rated current reach to 4000A.
- Application: mainly applicable in place with high automation and need to communicate with computer, like large power station and petrochemistry system, as the low voltage distribution device of the distribution and motor controlling, and reactive power compensation in power system.
- Protection degree: IP30, IP40
- Standard: IEC60439-1

General

Product code	A	B	C	D
GGD 06	600	600	450	556
GGD 06A	600	800	450	756
GGD 08	800	600	650	556
GGD 08A	800	800	650	756
GGD 10	1000	600	850	556
GGD 10A	1000	800	850	756
GGD 12	1200	800	1050	756

mm

### Ordering information

Please specify the following information when ordering:

1. The full model ,including main circuit plan and auxiliary circuit plan.
2. The diagram of main circuit system allocation.
3. Inner allocation diagram of the switchgear.
4. Electric diagram of auxiliary contact.
5. Name ,Model ,Specification and list of adopted components.
6. Customized products are available.





## Low Voltage Switchgear

### GCS Low-voltage Switchgear Panel, Withdrawable Type

#### Selection

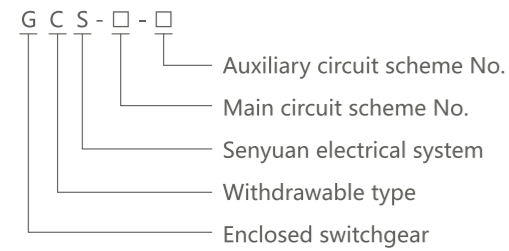

#### Operating conditions

- Ambient air temperature:  $-15^{\circ}\text{C} \sim +40^{\circ}\text{C}$   
Daily average temperature:  $\leq 35^{\circ}\text{C}$   
When the actual temperature exceed the range, it should be used by reducing the capacity accordingly.
- Altitude:  $\leq 2000\text{m}$
- Relative humidity:  $\leq 50\%$ , when temperature is  $+40^{\circ}\text{C}$   
When temperature is low, larger relative humidity is allowed. when it is  $+20^{\circ}\text{C}$ , relative humidity can be 90%. Since the temperature change will make out condensation.
- Installation inclination:  $\leq 5\%$
- Applicable in the places without corrosive and flammable gas.

Note: Customized products are available.

## Low Voltage Switchgear

### GCS Low-voltage Switchgear Panel, Withdrawable Type

#### Technical data

Sheet 1

Item	Data	
The main circuit of rated voltage(V)	AC400, 690	
The auxiliary circuit of rated voltage(V)	AC220, 400; DC110, 220	
Rated frequency(Hz)	50(60)	
Rated insulation voltage(V)	660(1000)	
Rated current(A)	Horizontal busbar	$\leq 4000$
	Vertical bus(MCC)	1000
Busbar rated short time withstand current(KA/1S)	50, 80	
Busbar rated peak withstand current(KA/0.1s)	105, 176	
Power frequency test voltage (V/1Min)	Main circuit	2500
	Auxiliary circuit	2000
Main Busbar	3 Phase 4 Wires	A, B, C, N
	3 Phase 5 Wires	A, B, C, PE, N

#### Features

- C type material adopted for the main frame, frame use the form of Assembling structure. Main frame have the installation modular hole  $E=20\text{mm}$
- The Compartment is divided into functional unit rooms, bus room, cable rooms,Each unit is relatively independent ."
- Take the drawer as main body, meanwhile have the draw out type and fixed type, can mixed combination, Arbitrary selection.
- Cabinet size (refer to sheet 2)

Sheet 2

Height	2200			
Width	400	600	800	1000
Depth	600	800	1000	

#### 5. Functional unit

- The higher modulus of drawer is 160mm, divide to 1/2 unit, 1 unit, 1.5unit, 2 unit,3 unit 5 different size series. Unit loop rated voltage below 400A.
- The same functional unit of the drawer has good interchangeability.Each MCC cabinet can install max 11 set drawer with 1 unit, or 22 sets drawer with 1/2 unit. Drawer with more than 1 unit adopt multi-functional plate .
- Drawer incoming and outgoing line adopt the same standardized plug of slice structure with different quantity according to current
- The transfer between  $\frac{1}{2}$  unit drawer and cable cabinet use ZJ-2 adapter..
- The transfer between drawer which is above 1 unit and cable cabinet use standardized bar type or tube type ZJ-1 adapter according to different current rated.
- Drawer panel have the open, close, test, draw out position indicator.
- Drawer unit have Mechanical linkage.
- Feeder cabinet and motor control cabinet have special cable insulation cabinet. The connection between functional unit and cable cabinet adopt adapter.Not only improves the reliability of the cable, and greatly facilitates the user safety and repair of cable.

## Low Voltage Switchgear

### GCS Low-voltage Switchgear Panel, Withdrawable Type

#### 6. Busbar

In order to improve the bus dynamic thermal stability and improved contact surface temperature rise, device use TMY-T2 series of hard copper, Copper plate surface will be treated with new advanced oxidation process. The performance index is superior to the traditional tin plating process.

##### 1) Horizontal busbar

Horizontal busbar is arranged in Busbar compartment at the back of cabinet, double busbar for above 2500 A, single layer busbar for current below 2500A. Each phase is composed of 4 or 2 pcs busbar, improve the Short circuit strength of bus.

##### 2) Vertical bus

"L" shape hard copper tin bus is used for vertical busbar of drawer. L type bus specification(mm):

(Height×thickness)+(button×Thickness)(50×5)+(30×5) Rated current 1000A

Neutral grounding busbar

##### 3) Adopt hard copper. Through the level of neutral grounding wire (PEN) or ground +neutral line (PE+N).

### Overall and mounting dimensions(mm)

Electric power, communication cabinet installation diagram

Picture 1

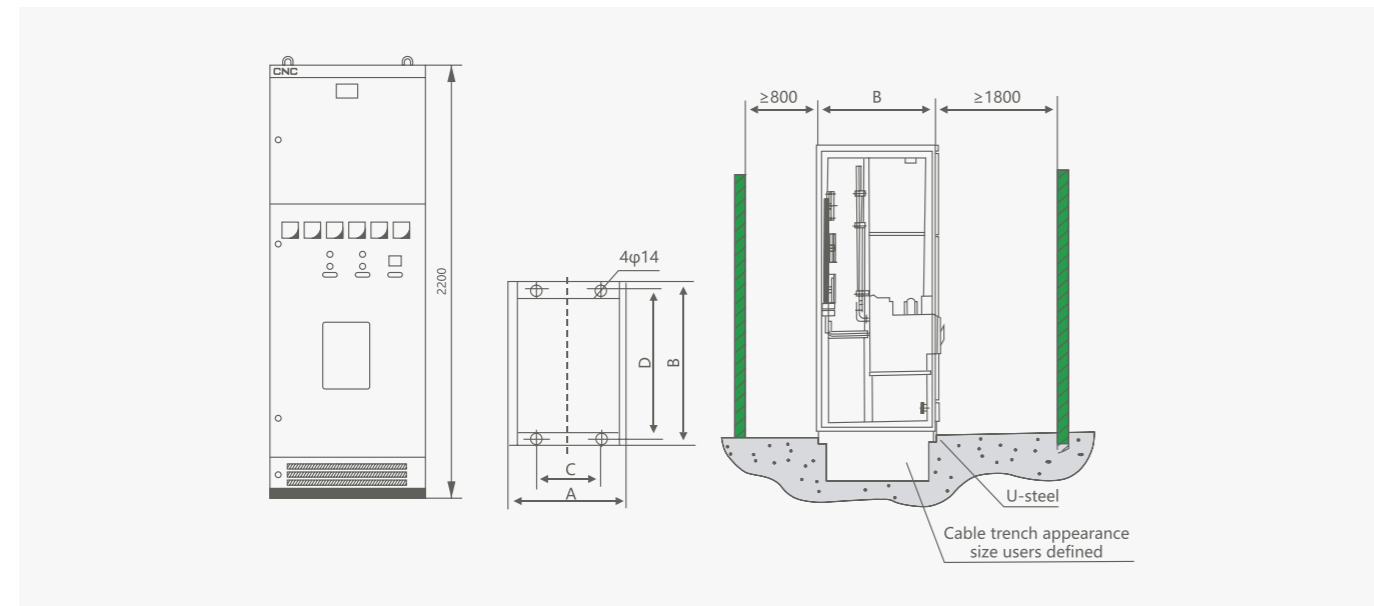

(mm) Sheet 3

Cabinet code	A	B	C	D	Remark
GCS-TG1010-4	1000	1000	900	900	Communication cabinet
GCS-TG0810-4	800	1000	700	900	Electric power cabinet
GCS-TG0808-4	800	800	700	700	Electric power cabinet
GCS-TG0608-4	600	800	500	700	Electric power cabinet

## Low Voltage Switchgear

### GCS Low-voltage Switchgear Panel, Withdrawable Type

PC cabinet installation diagram

Picture 2

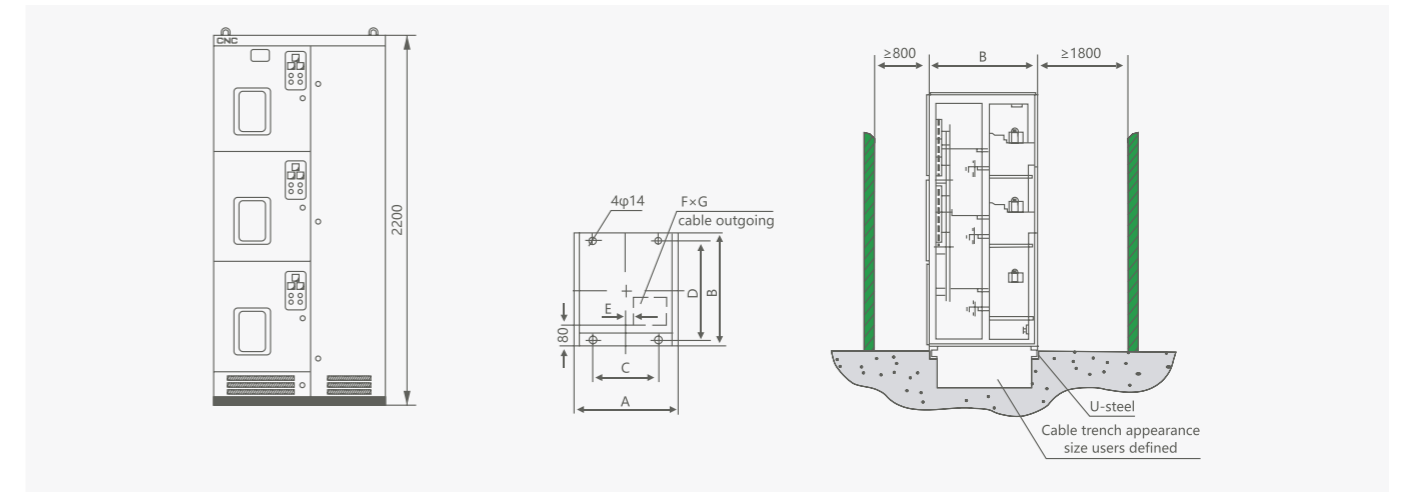

(mm) Sheet 4

Cabinet code	A	B	C	D	E	F×G
GCS-TG1010-2	1000	1000	900	900	60	400×400
GCS-TG0810-2	800	1000	700	900	160	200×400
GCS-TG1008-2	1000	800	900	700	60	400×400
GCS-TG0808-2	800	800	700	700	160	200×400

MCC cabinet installation diagram

Picture 3

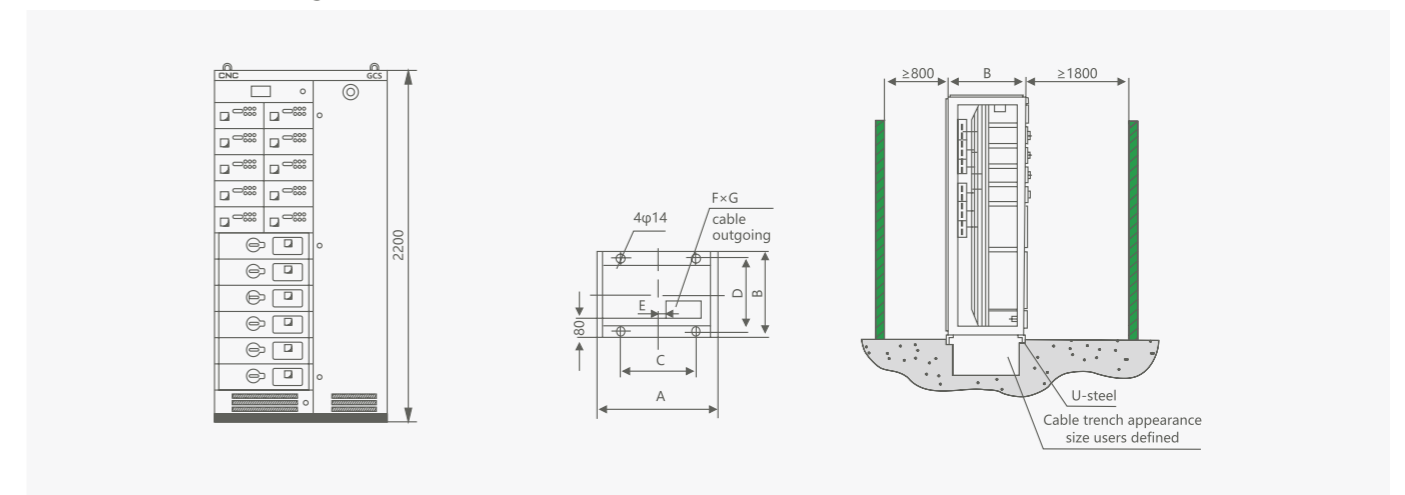

(mm) Sheet 5

Cabinet code	A	B	C	D	E	F×G
GCS-TG1008-1	1000	800	900	700	60	400×350
GCS-TG1006-1	1000	600	900	500	60	400×350
GCS-TG0806-1	800	600	700	500	160	200×350

# Low Voltage Switchgear

## GCS Low-voltage Switchgear Panel, Withdrawable Type

### Main single line diagram

Sheet 5

Program No.	01							02							03					04						
Single line diagram																										
Application	Electric power (up incoming)							Electric power (bottom incoming)							Electric power (Electric cable incoming)					Communication						
Specification No.	A	B	C	D	E	F	G	A	B	C	D	E	F	G	A	B	C	D	E	A	B	C	D	E	F	G
Short time withstand current/Instantaneous withstand current(kA)	80/176							80/176																		
	50/105							50/105							50/105					50/105						
	30/63							30/63							30/63					30/63						
Rated current(A)	4000	3150	2500	2000	1600	1000	630	4000	3150	2500	2000	1600	1000	630	2500	2000	1600	1000	630	4000	3150	2500	2000	1600	1000	630
YCW1-4000	1							1												1						
YCW1-3200		1							1												1					
YCW1-2000			1							1					1							1				
YCW1-2000				1							1					1							1			
YCW1-2000					1							1					1							1		
YCW1-2000						1							1						1						1	
YCW1-2000							1							1												1
SDL-□															(1)	(1)	(1)	(1)	(1)							
SDH-□□/5	3(4)	3(4)	3(4)	3(4)	3(4)	3(4)	3(4)	3(4)	3(4)	3(4)	3(4)	3(4)	3(4)	3(4)	3(4)	3(4)	3(4)									
Cabinet width(mm)	800(1000)			600				800(1000)			600				800		600			1000		800				
Cabinet depth(mm)	1000		800					1000		800					800					1000		800				
Small compartment height usage(mm)																										

# Low Voltage Switchgear

## GCS Low-voltage Switchgear Panel, Withdrawable Type

Continued Sheet 5

Program No.	05			06			07			08		
Single line diagram												
Application	Bus switching			Feeder			Dual power switch manually			Dual power switch manually		
Specification No.				A	B		A	B				
Short time withstand current/Instantaneous withstand current(kA)				80/176			50/105			50/105		
				50/105			50/105			30/63		
Rated current(A)	4000	3150	2500	2500	2000		1000	630		1000	630	
YCW1-2000					1							
YCW1-2000						1						
YCW1-2000							1					
YCW1-2000								1				
YCW1-2000												
SDL-□				(1)	(1)	(1)						
SDH-□□/5				1(3)						3(4)	3(4)	
Cabinet width(mm)	400(600)			1000			1000			1000		
Cabinet depth(mm)	400(600)			800(1000)			800			800		
Small compartment height usage(mm)				640								

# Low Voltage Switchgear

## GCS Low-voltage Switchgear Panel, Withdrawable Type

Continued Sheet 5

Program No.	09		10				11			12
Single line diagram										
Application	Dual power supply switching		Feeder				Feeder			Current-limiting reactor
Specification No.	A	B	A	B	C	D				
Short time withstand current/Instantaneous withstand current(kA)	50/105		50/105				50/105			
	30/63		30/63				30/63			
Rated current(A)	400	250	630	400	250	160	400	250	100	600
QSA-630			1							
QSA-400				1						
QSA-250					1					
QSA-160						1				
Current-limiting reactor 600A0.0084Ω/Φ										3
B370, LR1, CJ35	1									
B250, LR1, CJ35		1								
TG-400BD, YCM1-400L, TM30	1	1					1			
TG-225BD, YCM1-225M, TM30								1		
TG-100BD, YCM1-100M, TM30									1	
SDL-□			(1)	(1)						1
SDH-□□/5										
Cabinet width(mm)	800(1000)		1000				800(1000)			800
Cabinet depth(mm)	600(800)		800(1000)				600(800)			600
Small compartment height usage(mm)	480×2		480	320			240(160)			

Main electric components

# Low Voltage Switchgear

## GCS Low-voltage Switchgear Panel, Withdrawable Type



Continued Sheet 5

Program No.	13	14	15
Single line diagram			
Application	Potential transformer	Potential transformer	Potential transformer
Specification No.			
Rated current(A)			
QSA-63		1	1
NT00-□	3		
JDG-0.5 380/100	2	2	1
JSGW-0.5			
SDH-□□/5			
Cabinet width(mm)	Install in the electric power cabinet or 05 scheme Switching cabinet, connect with branch bus, Not occupy the space.		
Cabinet depth(mm)			
Small compartment height(mm)			

Continued Sheet 5

Program No.	16			17			18
Single line diagram							
Application	Static Var Compensator			Static Var Compensator			Public power
Specification No.	A	B	C	A	B	C	
Max control motor power (kW)	160	128	96	160	128	96	
QA -400	1	1	1	1	1	1	
am-32	30	24	18	30	24	18	
NT00-□							3
JBK3-400							1
B30C	10	8	6	10	8	6	
T45, LR1	10	8	6	10	8	6	
BCMJ-0.4-16-3	10	8	6	10	8	6	
SDH-□□/5	3	3	3	3	3	3	
Cabinet width(mm)	1000	800		1000	800		
Cabinet depth(mm)	800 (600)			800 (600)			
Small compartment height usage(mm)							

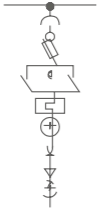
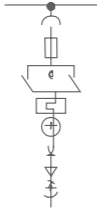
Main electric components

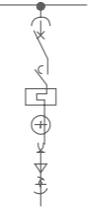
Program No.	19	20	21	22					
Single line diagram									
	Motor (reversible)		Motor (reversible)	Motor (irreversible)			Motor (irreversible)		
Specification No.	A	B	7.5	A	B	C	A	B	
Max control motor power (kW)	37	15		100	75	75	37	15	7.5
Main electric components	QSA-125	1							
	HH17-63		1	3					
	NT00-□								
	YCM1-400L or TG-400BD, TM30				1				
	YCM1-225M, TM30, TG225BD					1	1		
	YCM1-1000L or TG-100BD, TM30							1	1
	NZMS4, TM30								1
	B250, LC1, CJ35				1				
	B170-105, LC1, CJ35					1	1		
	B85 or LC1-D80	2						1	
	B45 or LC1-D32		2						1
	B16 or LC1-D18			2					1
	T85, LR1	1						1	
	TSA45, LC1		1					1	
	T16, LR1			1	1	1	1		1
	SDL-□	(1)	(1)	(1)	(1)	(1)	(1)	(1)	(1)
SDH-□□/5	1	1	1	3	3	3	1	1	
Small compartment height usage(mm)	320	160	160	480	320	320	160		

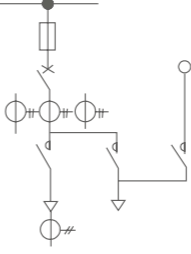
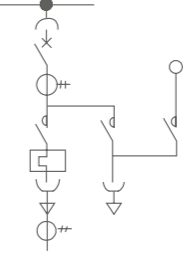
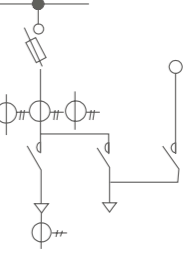
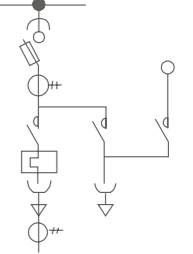
Program No.	23	24	25	26					
Single line diagram									
Application	Y-Δ Start		Y-Δ Start						
Specification No.	A	B	A	B	A	B	A	B	
Max control motor power (kW)	160	90	37	15	160	90	37	15	
Main electric components	QSA-400~250				1	1			
	QSA-125						1		
	HH17-63							1	
	NT3-□	3							
	TG-400B	1							
	YCM1-225 or TG-225D		1						
	YCM1-100M or TG-100D			1	1				
	B370+B250	2+1				2+1			
	B250+B170		2+1				2+1		
	B85 or LC1-D80			3				3	
	B45, TC1-D32 or 3TB44				3				3
	T85			1				1	
	TSA45				1				1
	T16	1	1			1	1		
	SDL-□	(1)	(1)	(1)	(1)	(1)	(1)	(1)	(1)
	SDH-□□/5	3	3	1	1	1	1	1	1
Cabinet width(mm)									
Cabinet depth(mm)									
Small compartment height usage(mm)	1120	960	320		800		320		

## Low Voltage Switchgear

### GCK Low-voltage Switchgear Panel, Withdrawable type

- Application: mainly applicable in places with high automation and need to communicate with computer, like large power station and petrochemistry system, as the low voltage distribution device of the distribution and motor controlling, and reactive power compensation in power system.
- Protection degree: IP30, IP40. Bus type: three phase four wires, three phase five wires. Operation type: in-place, long-distance and automatic
- Standard: IEC60439-1

#### General

## Low Voltage Switchgear

### GCK Low-voltage Switchgear Panel, Withdrawable type

#### Selection

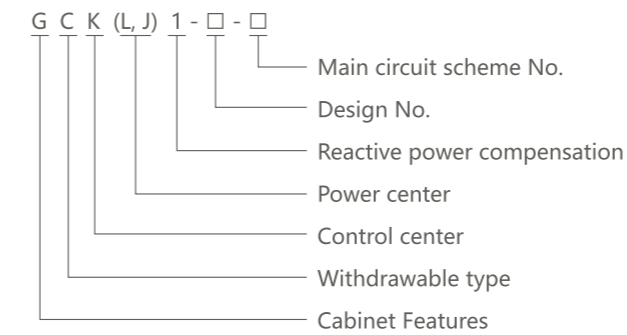

#### Operating conditions

1. Ambient air temperature:  $-5^{\circ}\text{C}\sim+40^{\circ}\text{C}$ .  
Daily average temperature:  $\leq 35^{\circ}\text{C}$ .  
When the actual temperature exceed the range, it should be used by reducing the capacity accordingly.
2. Transport and store temperature:  $-25^{\circ}\text{C}\sim+55^{\circ}\text{C}$ . do not exceed  $+70^{\circ}\text{C}$  in short time.
3. Altitude:  $\leq 2000\text{m}$ .
4. Relative humidity :  $\leq 50\%$ , when temperature is  $+40^{\circ}\text{C}$ .  
When temperature is low, larger relative humidity is allowed. when it is  $+20^{\circ}\text{C}$ , relative humidity can be 90%. Since the temperature change will make out condensation.
5. Installation inclination:  $\leq 5\%$
6. Applicable in the places without corrosive and flammable gas.

Note: Customized products are available.

#### Technical data

1. Electric datas
  - 1) Rated insulation voltage: 690V/1000V
  - 2) Rated operational voltage: 400V/690V
  - 3) Rated frequency: 50/60Hz
  - 4) Rated impulse withstands voltage: 8kV
  - 5) Rated voltage of auxiliary circuit: AC380/220V, DC110/220V
  - 6) Over-voltage grade: III
  - 7) Rated current:  $\leq 5000\text{A}$
  - 8) Rated current of horizontal bus bar:  $\leq 5000\text{A}$
  - 9) Rated current of vertical bus bar: 1000A
2. Mechanical items
  - 1) Incoming and outgoing mode
  - 2) Cable incoming and outgoing
  - 3) Connection mode
  - 4) The functional units completely separated or partially separate



## GCK Low-voltage Switchgear Panel, Withdrawable type



### Feature

GCK panel is combination structure with bolt. The complete panel is composed of door, terminal board, baffle plate, supporting frame and drawer, busbar, etc. Basic frame adopts FA28 type or KB type (C type) to combine with together. Total structural components of frame are connected by self-tapping screw. It should add to door, face plate, baffle plate, supporting frame and drawer to finish completed panel by requirements.

The installation hole of body and components modules  $E=25\text{mm}$  change, flexible and convenient to install.

Drawer unit height divide into  $\frac{1}{2}$  unit, 200mm, 300mm, 400mm, 500mm, and 600mm series. The loop current decide the drawer height, virtual installation height is 1800mm.

GCK panel withdrawable function unit adopts special push (pull) mechanism, light structure, perfect interchange. It indicate of working position, test position and isolating position mechanical locking condition. Install additional pad lock for operating handle.

The frame and inner metal components are galvanized to assure reliable earthing. GCK basic frame is combination assembly type structure, adopt standardized module design. for combination assembly type structure, the standard module design. Compact structure, flexible assembly, can be assembled into a protection, measurement and control, indicating etc. standard unit, Can choose assembly according to requirement, To form different frame Features and drawer unit.

#### 1. The cabinet frame

C type material adopted for the main frame, Frame parts and Special parts will be provided by our company to make sure the accuracy and quality.

- Parts forming size, hole size, Equipment interval adopt modularization. ( $E=25\text{mm}$ )
- The internal structure should be galvanized.
- The top cover is detachable, horizontal bus can be installed easily after removing the top cover, Hand ring
- External phosphating treatment; Then use electrostatic epoxy powder coating.
- Cabinet frame is divided into the busbar compartment, functional compartment, the cable compartment three separate interval, Can prevent accidents diffusion and convenient charged repair.

#### 2. Functional unit (Withdrawable part)

- Functional unit: Feeder unit, Motor unit, utility power unit.
- The high modulus of drawer unit is 200mm, include  $\frac{1}{2}$ unit, 1unit, 2 unit, 3 unit four size series.  
Unit loop rated current below 630A.
- Each MCC Cabinet can install 9 set drawer with 1 unit, or 18 set drawer with  $\frac{1}{2}$  unit.



## GCK Low-voltage Switchgear Panel, Withdrawable type



- The compartment door plate is interlocked between operating mechanism and drawer, the door can be open until the main switch is on the close position
- The main switch operating mechanism can be locked in close or open position by a padlock, the equipment can be maintained safely.
- There are main circuit outlet plug, auxiliary circuit secondary plug and earthing plug at the back of function unit.
- The earthing plug make sure the protection circuit continuity when drawer on Separation tests connection position.
- Functional unit compartment by metal partition board.
- Compartment valve, can be open and close automatically, with drawers pushed and pulled so that in the compartment without touching the vertical busbar.

#### 3. Busbar system

- Vertical bus uses polycarbonate engineering plastic shell sealed
- GCK, GCL busbar system use 3P4W, 3P5W, Horizontal busbar will be installed at the top of cabinet, N phase, PE phase. Can be installed on the top of the cabinet, and can also be arranged in the cabinet bottom.

### Overall and mounting dimensions(mm)

The effective height of installation

1. Electric cabinet and buscouple cabinet  
Cabinet width can be 600,800,1000,1200,(800-400)mm according to rated current and method of incoming and outgoing.  
Depth of cabinet is 800,1000(Advise to use 1000mm, The top incoming and top outgoing must be 1000mm)
2. Feeder cabinet  
Cabinet Width: 600, 800mm  
Cabinet depth: 600, 1000 (advise to use 1000mm top outgoing cabinet must be 1000mm)
3. Motor control cabinet  
Width: 600, 600+200mm  
Depth of cabinet: 800, 1000mm(advise to use 1000mm top outgoing cabinet must be 1000mm)  
Power compensation cabinet  
Width: 600(4, 6 loop), 800(8), 1000(10 loop)mm  
cabinet depth: 800, 1000mm

## Low Voltage Switchgear

### GCK Low-voltage Switchgear Panel, Withdrawable type



Rated current (A)	Copper bus model (mm)
630	50×5
1250	60×10
1600	80×10
2000	100×10
2500	2(80×10)
3150	2(100×10)

mm



## Low Voltage Switchgear

### GCK Low-voltage Switchgear Panel, Withdrawable type

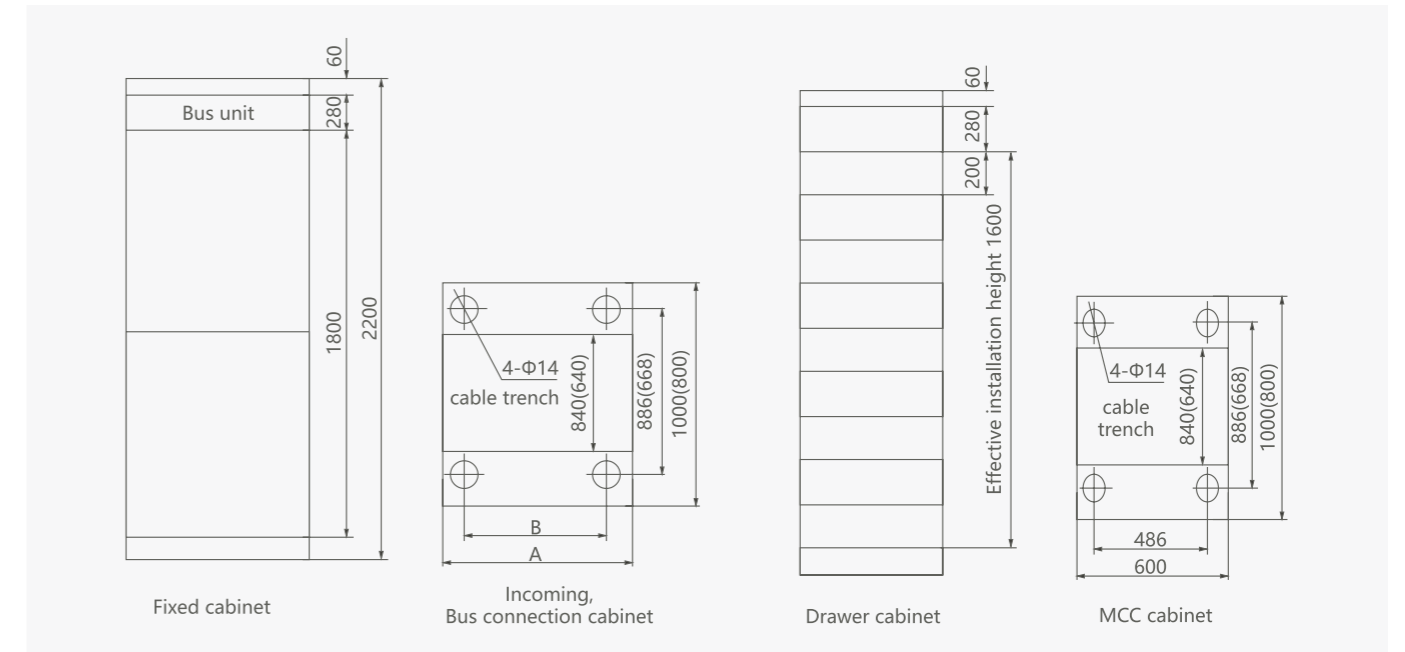

Item	Size	A	B
Electric power or Electric feeder		600	486
Electric power or Bus connection		800	686
Electric power or Bus connection		1000	886

### Main single line diagram

Sheet 2

Program No.	01	02	03	04	05	06	07
Single line diagram							/
Application	Overhead power		Cable power		Buscouple		/
Rated current (A)	630~1600	2000~3150	630~1600	2000~3150	630~1600	2000~3150	/
Circuit breaker	ME630~ME3205, AH6B~AH30C, M08~M32, YCW1-2000, YCW1-3200						/
Current transformer	LMK-0.66□/5						/
Cabinet width(mm)	800	1000	800	1000	800	1000(1200)	/
Small compartment height(mm)	1800	1800	1800	1800	1800	1800	/
Instruction	When the rated current exceeds 3150A, the user should consult with the manufacturer.						



Program No.		08		09		10		11			
Single line diagram											
Application		Electric feeder		Electric feeder		Electric feeder		Electric feeder			
Main electrical components	Circuit breaker	ME630~ME1000 M08~M10 YCW1~2000		YCM1-100 YCM1-250	TO-400B YCM1-400 YCM1-400	QSA-63 QSA-125	QSA-250 QSA-400	QSA-630			
	Current transformer	LMK-0.66		LMK-0.66	LMK-0.66	LMK-0.66	LMK-0.66	LMK-0.66			
Cabinet width(mm)		600		600	600	600	600	600			
Small compartment height(mm)		/		200	300	400	600	200	300	400	600
Instruction		Each set can install two loops		The number of measuring transformer is selected according to the practical situation							

Program No.		12				13		
Single line diagram								
Application		Motor control				Motor control		
Main electrical components	Circuit breaker knife fuse switch	TG-30B	TG-100B	TG-225B	TG-225B	QSA-63	QSA-125	QSA-125
		CM1-63	CM1-100	CM1-225	CM1-225	/	/	/
		YCM1-100	YCM1-100	YCM1-225	YCM1-225	/	/	/
	Contactor	B9-B45	B45-B85	B105-B170	B250	B9-B45	B45-B85	B105-B170
Thermal relay	T16-T45	T45-T105	*T16	C	T16-T45	T16-T45	*T16	
Current transformer	LMK-0.66	LMK-0.66	LMK-0.66	LMK-0.66	LMK-0.66	LMK-0.66	LMK-0.66	
Cabinet width(mm)		600	600	600	600	600	600	600
Small compartment height(mm)		200	200	400	600	200	200	400
Instruction		≤11KW	≤30KW	≤55KW	≤105KW	≤15KW	≤30KW	≤55KW
		According to each cabinet circuit number, the appliance should consider the heating capacity * adopt current transformer protection. 7.5KW and below can also adopt 1/2 unit.						

Program No.		14			15	
Single line diagram					/	
Application		Motor reversible control			/	
Main electrical components	Circuit breaker knife fuse switch	TG-30B	TG-100B	TG-225B	/	
		CM1-63	CM1-100	CM1-225	/	
		YCM1-100	YCM1-100	YCM1-225	/	
	Contactor	B9-B45	B45-B85	B105-B170	/	
Thermal relay	T16-T45	T45-T105	*T16	/		
Current transformer	LMK-0.66	LMK-0.66	LMK-0.66	/		
Cabinet width(mm)		600	600	600	/	
Small compartment height(mm)		200	200	400	/	
Instruction		≤11KW	≤30KW	≤55KW	/	
		According to each cabinet circuit number, the appliance should consider the heating capacity * adopt current transformer protection. 7.5KW and below can also adopt 1/2 unit.				

Program No.		16			17		
Single line diagram							
Application		Motor reversible control			Y-Δ Motor control		
Main electrical components	Knife fuse switch	QSA-63	QSA-125	QSA-250	QSA-63	QSA-125	QSA-250
		B9-B45	B45-B85	B105-B170	B9-B45	B45-B85	B105-B170
		T16-T45	T45-T105	*T16	T16-T45	T45-T105	*T16
	Current transformer	LMK-0.66	LMK-0.66	LMK-0.66	LMK-0.66	LMK-0.66	LMK-0.66
Cabinet width(mm)		600	600	600	600	600	600
Small compartment height(mm)		200	300	600	300	400	600
Instruction		≤15KW	≤30KW	≤55KW	≤15KW	≤30KW	≤55KW
		According to each cabinet circuit number, the appliance should consider the heating capacity * adopt current transformer protection.					

Continued Sheet 2

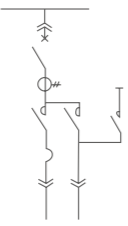
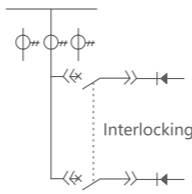
Program No.		18			19
Single line diagram					
Application		Y-Δ Motor control			Power supply change over
Main electrical components	Circuit breaker	TG-30B	TG-100B	TG-225B	ME630~1000A
		CM1-63	CM1-100	CM1-225	AH600~1000A
		YCM1-63	YCM1-100	YCM1-225	M800~1000A YCW1-2000
	Contactor	B9-B45	B45-B85	B105-B170	/
	Thermal relay	T16-T45	T45-T105	*T16	/
Current transformer	LMK-0.66	LMK-0.66	LMK-0.66	LMK-0.66	
Cabinet width(mm)		600	600	600	600(800)
Small compartment height(mm)		300	300	600	1800
Instruction		≤11KW	≤37KW	≤75KW	Electric interlocking automatic or manual switch
		According to each cabinet circuit number, the appliance should consider the heating capacity * adopt current transformer protection.			

Low Voltage Switchgear

**MNS Low-voltage Switchgear Panel, Withdrawable Type**

- MNS low-voltage withdrawable switchgear is suitable for power systems with an AC 50Hz and a rated working voltage of 400V. It is mainly used for energy conversion, distribution, and control of distribution equipment.
- Mainly suitable for airports, power stations, transportation and energy, industrial and mining enterprises, residential communities, and other places.
- Standard: IEC439

**General**

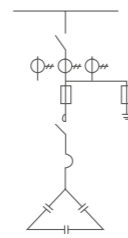
Program No.		20		21	22
Single line diagram					
Application		6 Loops power compensation		8 Loops power compensation	10 Loops power compensation
Main electrical components	Knife fuse switch	QSA400	QSA400	QSA400	QSA400(630)
	Fuse	NT00	NT00	NT00	NT00
	Contactor	Cj19	Cj19	Cj19	Cj19
	Capacitor	BSMJ0.415-20-3	BSMJ0.415-20-3	BSMJ0.415-20-3	BSMJ0.415-20-3
	Reactive power compensation	JKL	JKL	JKL	JKL
	Current transformer	LMK-0.66	LMK-0.66	LMK-0.66	LMK-0.66
	Surge arrester	FYS-0.22	FYS-0.22	FYS-0.22	FYS-0.22
Cabinet width(mm)		600	800	800	800(1000)
Small compartment height(mm)		1800	1800	1800	1800
Instruction		When used for auxiliary cabinet, eliminate the reactive compensator Automatic switching is controlled by main cabinet			



## Low Voltage Switchgear

### MNS Low-voltage Switchgear Panel, Withdrawable Type

#### Selection

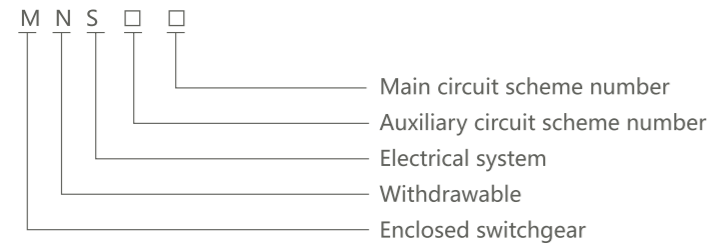

#### Operating conditions

1. Installation Site: Indoor;
2. Altitude: No more than 2000m.
3. Earthquake Intensity: No more than 8 degrees.
4. Ambient Temperature: No more than +40°C and no less than -15°C. Average temperature is no more than +35°C within 24 hours.
5. Relative Humidity: the average daily value is no more than 95%, the average monthly value is no more than 90%.
6. Installation locations: without fire, explosion danger, serious pollution, chemical corrosion and violent vibration.

#### Features

1. The operation and control handle of the drawer are combined into one, simplifying the operation while retaining the mechanical interlocking function. This overcomes the drawbacks of complex operation and susceptibility to damage in traditional MNS cabinets due to possible misoperation.
2. The MCC units are available in various combinations, compact in structure, and the cabinet can share back-to-back arrangement of busbars. Each cabinet can accommodate up to 36 circuits.
3. The cabinet can be arranged back-to-back or against the wall, saving installation space.
4. Standard components are used throughout, making it convenient for engineering designers.
5. The entire series is standardized, with strong structural versatility and flexible assembly.
6. A single cabinet can accommodate more units and can be freely combined into different types, such as fixed partition type and drawer type. Drawer units of the same specifications can be easily interchanged.
7. Stable combination performance and good grounding continuity.
8. High continuity and reliability of equipment operation.
9. The product has passed earthquake resistance, salt spray, and EMC electromagnetic compatibility tests, ensuring safe and reliable operation.

## Low Voltage Switchgear

### MNS Low-voltage Switchgear Panel, Withdrawable Type

#### Technical data

No.	Content	Unit	Value	
1	Rated Operating Voltage	V	400	
2	Rated Insulation voltage	V	690	
3	Rated Frequency	Hz	50/60	
4	Main Bus-Bar	Rated Current	A	≤6300
		Rated Short-time Withstand Current	kA	≤100
		Rated Peak Withstand Current	kA	≤220
5	Distribution Bus	Rated Current	A	≤1300
		Rated Short-time Withstand Current	kA	≤50
		Rated Peak Withstand Current	kA	≤105
6	Frequency Withstand Voltage in 1min of Aux Control Loop	kV	1.89	
7	Rated Impulse Withstand voltage	kV	8	
8	Protection Degree	IP	IP40	
9	Electrical Clearance	mm	≥10	
10	Creepage Distance	mm	≥12.5	
11	Overvoltage Level	-	III/IV	
12	Pollution Degree	-	3	

#### Switchgear type

Power Center Cabinet

It adopts fixed installation withdrawable switches with various high-breaking capacity ranging from 630A to 630A, featuring advanced and intelligent circuit breakers.

Drawer type

Assembled with drawers of different sizes, each circuit's main switch adopts high-breaking capacity plastic case circuit breakers or load switches with rotary-type fuse.

Fixed type:

MCC cabinet (Motor Control Center cabinet) functional units are assembled using plug-in plastic case circuit breakers, offering distinct breaking points and advantages such as enhanced safety and reliability.

Drawer/Fixed type:

There are five standard sizes, all based on a height of 8E (200mm).

8E/4: Assemble 4 drawer units in an 8E height space.

8E/2: Assemble 2 drawer units in an 8E height space.

8E: Assemble 1 drawer unit in an 8E height space.

16E: Assemble 1 drawer unit in a 16E (400mm) height space.

24E: Assemble 1 drawer unit in a 24E (600mm) height space.

## Low Voltage Switchgear

### MNS Low-voltage Switchgear Panel, Withdrawable Type

Five types of drawer units can be assembled in a single cabinet or as a mixed assembly. The maximum number of fixed units for a single assembly in a cabinet is shown in Table 1

	8E/4	8E/2	8E	16E	24E
Maximum number of units	26	18	9	4	3



8E/4



8E/2



8E



16E



24E

Overall and mounting Overall and mounting dimensions(mm) s of the cabinet

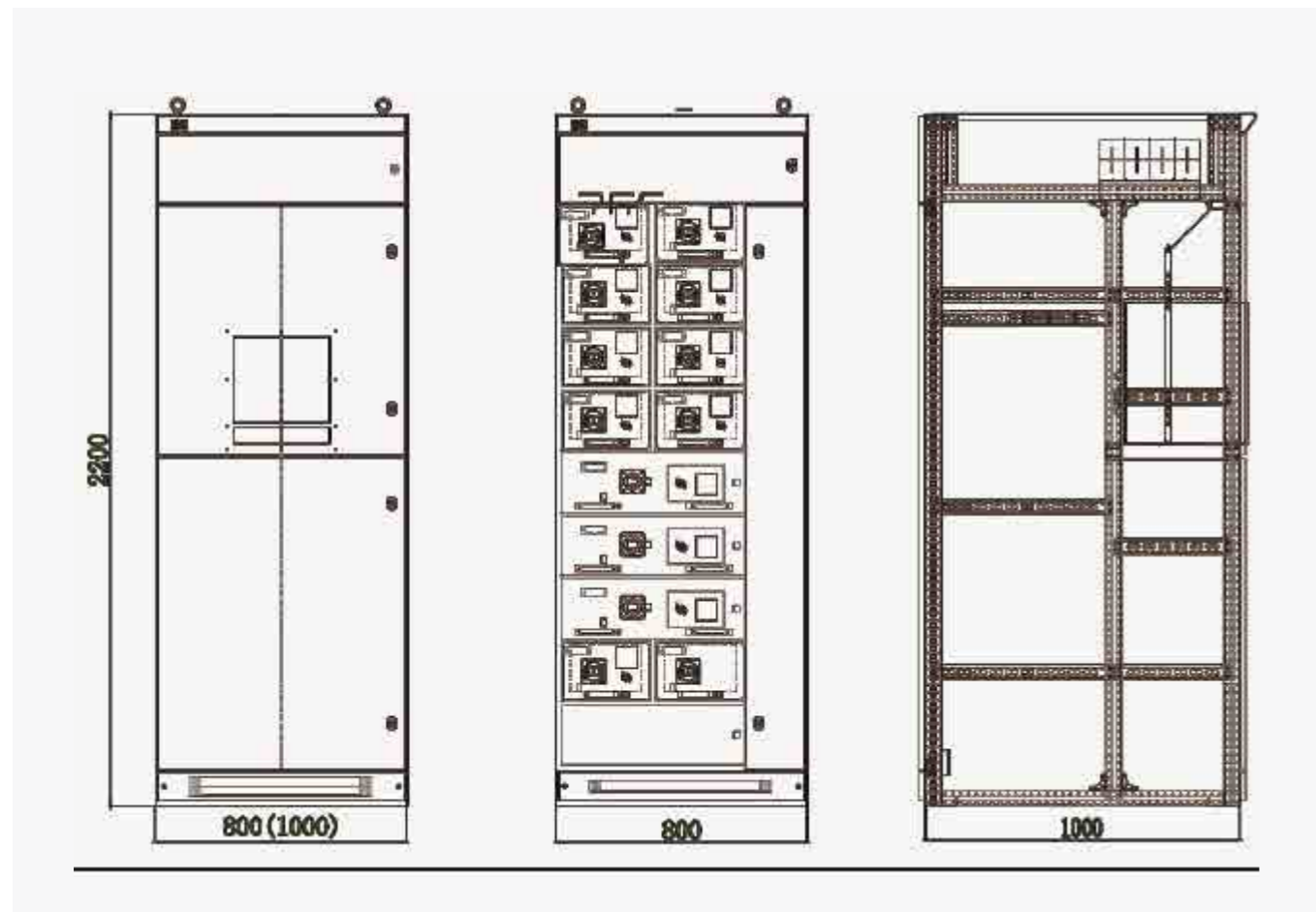

## Low Voltage Switchgear

### XL Low Voltage Power Distribution Cabinet

- ❖ The XL-21 low voltage power distribution cabinet is suitable for three-phase four-wire systems with AC voltages up to 500V. It is primarily used for power distribution purposes in power plants, industrial and mining enterprises, high-rise buildings, and other occasions.
- ❖ The XL-21 low-voltage power distribution cabinet is securely wall-mounted and allows for front-panel maintenance and inspection.

General



## Low Voltage Switchgear **XL** Low Voltage Power Distribution Cabinet

- ❖ The XL-21 low voltage power distribution cabinet is suitable for three-phase four-wire systems with AC voltages up to 500V. It is primarily used for power distribution purposes in power plants, industrial and mining enterprises, high-rise buildings, and other occasions.
- ❖ The XL-21 low-voltage power distribution cabinet is securely wall-mounted and allows for front-panel maintenance and inspection.

### General

## Low Voltage Switchgear **XL** Low Voltage Power Distribution Cabinet

### Schematic diagram of structure

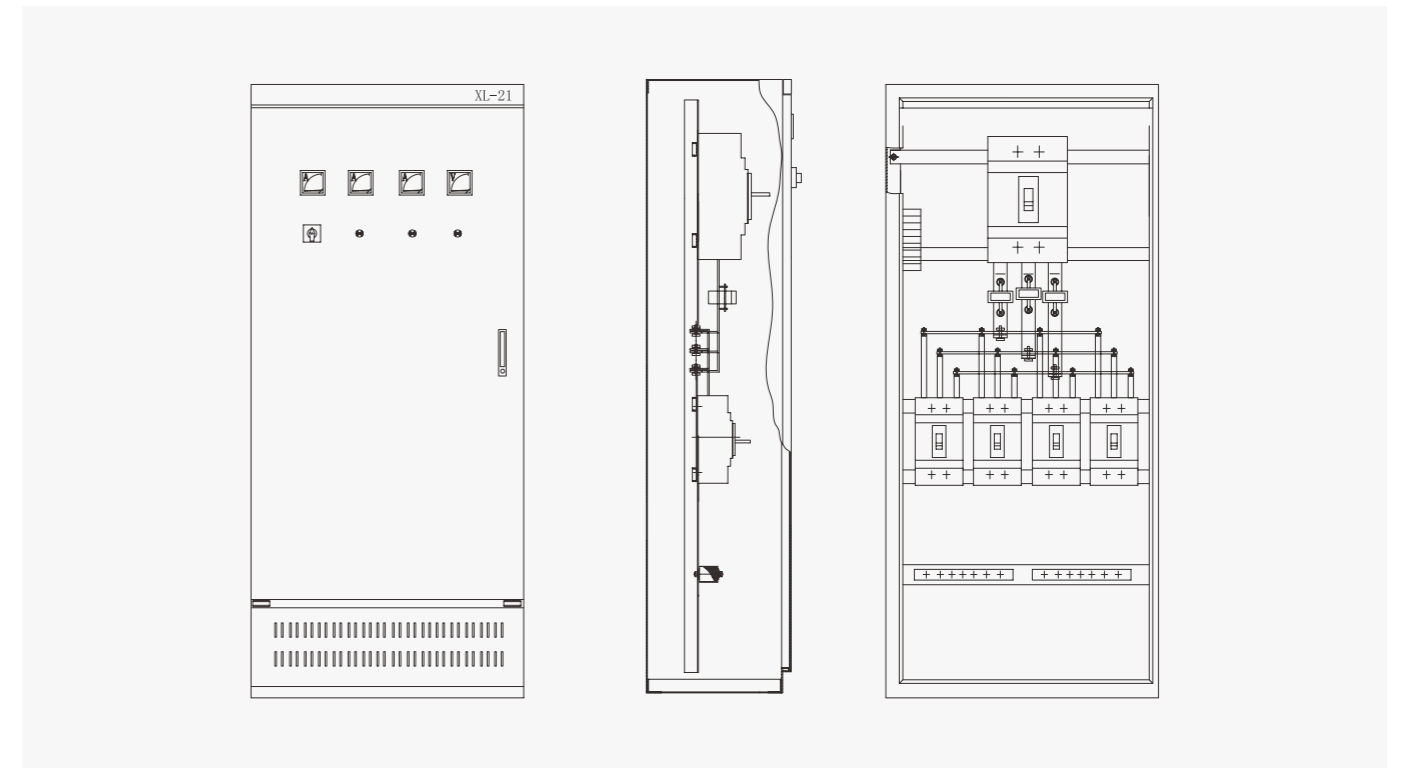

\*: Sizes are customized as needed

## Low Voltage Switchgear **JXF** Low-voltage Integrated Distribution Box

- Application: mainly applicable in places with high automation and need to communicate with computer, like large power station and petrochemistry system, as the low voltage distribution device of the distribution and motor controlling, and reactive power compensation in power system.
- Protection degree IP30, IP40. Bus type: three phase four wires, three phase five wires. Operation type: in-place, long-distance and automatic
- Standard: IEC60439-1

### General

## Low Voltage Switchgear **JXF** Low-voltage Integrated Distribution Box

### Selection

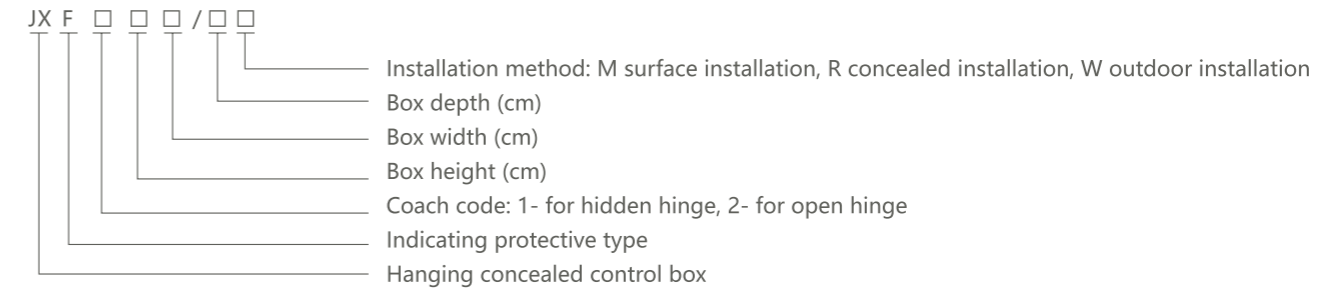

### Operating conditions

- 1.Installation Site: Indoor or outdoor;
- 2.Atitude: No more than 2000m.
- 3.Earthquake Intensity: No more than 8 degrees.
- 4.Ambient Temperature: No more than +40°C and no less than -25°C.Averagetemperature is no more than +35°C within 24 hours.
- 5.Relative Humidity: the average daily value is no more than 95%, the averagemonthly value is no more than 90%.
- 6.Installation locations: without fire,explosion danger. serious pollution,chemical corrosion and violent vibration.

### Features

- 1.Harmonious and beautiful color matching.
- 2.Standardized design, compact structure,strong versatility
- 3.The size of the box can be changed according to the demand .
- 4.The electric mounting plate can be detachable separately.
- 5.It has dozens of single line scheme numbers or derivative scheme numbersfor choice and wide range of application.

### Technical data

No.	Content	Unit	Value
1	Rated operating voltage	V	380
2	Rated Insulation voltage	V	500
3	Raled Frequency	Hz	50/60
4	Max Operation Current	A	≤250
5	Frequency Withstand Voltage in 1min of Aux Control Loop	kV	1.89
6	Rated Impulse Withstand voltage	kV	2.5
7	Protection degree	IP	Ip30
8	Electrical Clearance	mm	≥3
9	Creepage Distance	mm	≥10

\*: Sizes are customized as needed